

A professional-grade stainless steel gas range is shown in a kitchen setting. The range has a large stainless steel hood above it. A black frying pan is tilted over one of the burners, which is lit with a blue flame. The pan contains a variety of fresh ingredients including shrimp, chicken, vegetables, and a piece of fish. The range has a control panel with several knobs and a large handle on the oven door. The background is a dark blue wall, and the countertop is made of white marble. A green plant is visible in the bottom left corner.

*2025 Products*  
**CATALOG**

ENTREE LLC..

Tel: (704) 900 2068 E-mail: [solaris@entree.biz](mailto:solaris@entree.biz) Web: [www.entree.biz](http://www.entree.biz)

S



O



L



A



R



I



S



ENTREE LLC..

Tel: (704) 900 2068 E-mail: solaris@entree.biz Web: www.entree.biz



# Catalog

## **New Products 04**

Speed Oven.....05  
Heavy Duty Steamer.....07

## **Gas Range Series 08**

Gas Range.....09  
Gas Range/Griddle Combos.....12  
Gas Range/Griddle/Salamander Combos.....15

## **Fryer Series 16**

Gas Fryer.....19

## **Convection Oven Series 20**

Gas Convection Oven.....22

## **Heavy Duty Series 23**

Gas Countertop Hotplates.....24  
Gas Countertop Griddle.....26  
Gas Thermostatic Griddle.....27  
Gas Countertop Charbroiler.....28

## **Medium Duty Series 30**

Gas Countertop Hotplates.....31  
Gas Countertop Griddle.....32  
Gas Thermostatic Griddle.....34  
Gas Countertop Charbroiler.....36

## **Standard Series 38**

Gas Countertop Griddle.....39  
Gas Countertop Charbroiler.....41

## **Electric Series 43**

Fryer..... 44  
Electric Convection Oven..... 48  
Griddle.....52  
Food Warmer.....57



**REDEFINING  
PERFORMANCE.  
REDEFINING  
VALUE.**

The next generation of professional kitchen technology is here - crafted for excellence, priced for accessibility.

**EXPERIENCE SOLARIS**

Premium Quality.  
Practical investment.



## Introducing the Solaris Speed Oven

**HSB 208/240**

### Features

- Top-mounted microwave system with single magnetron
- Integrated stirrer for uniform microwave distribution
- Built-in catalytic filter, removable and replaceable
- External air filter
- Exhaust port with integrated grease pan
- Heavy-duty door hinges designed for commercial use
- 5-inch touchscreen control panel
- Intelligent cooking system with up to 1,024 programmable recipes
- USB-enabled software and recipe updates
- Single-phase electrical connection
- Integrated self-diagnostic oven system
- Power cord and plug (optional)

Size(W\*D\*H): 458.7 × 677.9 × 652.5 mm  
Size(W\*D\*H): 18.06\*26.69\*25.69"

N.W. : 145.5 lbs or 65.95 kg  
Volts : 208/240 VAC / 3.25 or 3.85  
Capacity: 4.5 / 9.92 lbs

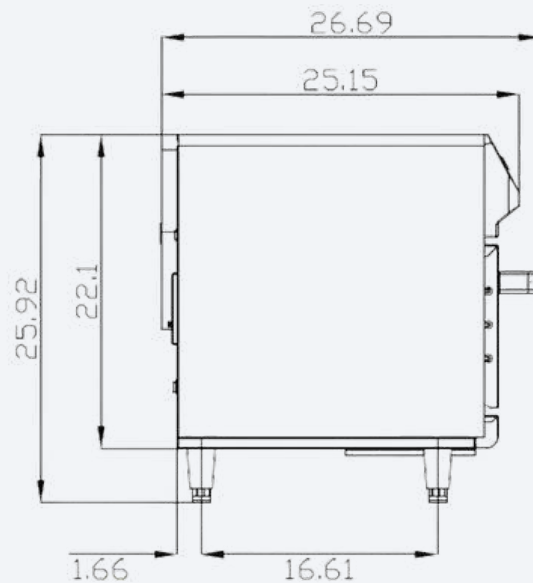
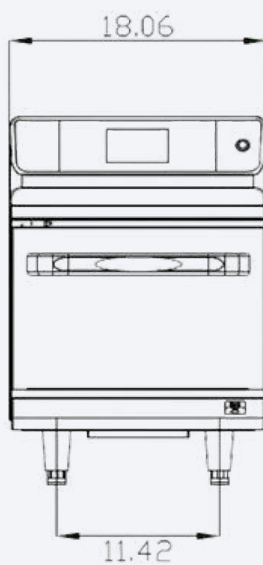

ENTREE LLC..

Tel: (704) 900 2068 E-mail: solaris@entree.biz Web: www.entree.biz



### Introducing the Solaris Speed Oven

**HSS 208/240**

### Features

- Top-mounted microwave system with single magnetron
- Integrated stirrer for uniform microwave distribution
- Built-in catalytic filter, removable and replaceable
- External air filter
- Exhaust port with integrated grease pan
- Heavy-duty door hinges designed for commercial use
- 5-inch touchscreen control panel
- Intelligent cooking system with up to 1,024 programmable recipes
- USB-enabled software and recipe updates
- Single-phase electrical connection
- Integrated self-diagnostic oven system
- Power cord and plug (optional)

Size(W\*D\*H): 458.7 × 677.9 × 652.5 mm  
 Size(W\*D\*H): 18.06\*26.69\*25.69”

N.W. : 145.5 lbs or 65.95 kg  
 Volts: 208/240 VAC / 3.25 or 3.85  
 Capacity: 4.5 / 9.92 lbs

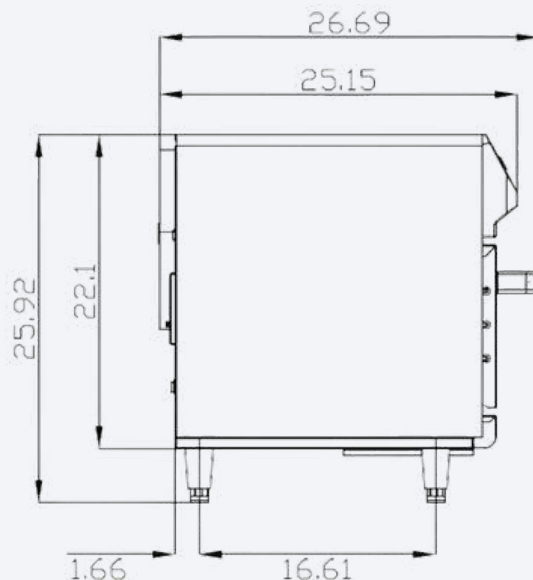
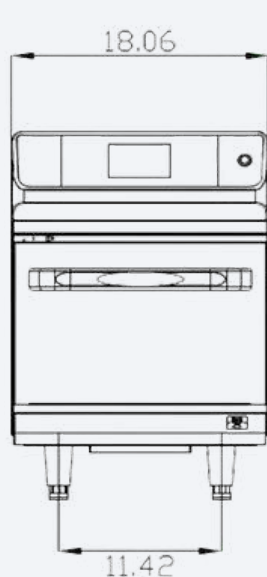



## Introducing the Solaris Speed Oven

**SCS-3-208/SCS-3-240**

**SCS-5-208/SCS-5-240**

### Features

- 201 series stainless steel exterior
- 304 series stainless steel interior with covered corners
- Heavy-duty stainless steel door with removable liner
- Full-perimeter door gasket
- Positive slide-lock door mechanism with spring-release
- Ready indicator light
- Cooking indicator light
- Add-water indicator light with audible alarm
- Digital timer with end-of-cycle audible alarm
- 4-inch adjustable non-skid legs
- Removable stainless steel pan supports
- Removable steam diffuser plate to prevent debris from entering the water reservoir
- Selectable timed or constant steam cooking mode

#### SCS-3-208/240

Chamber Size: 353 × 533 × 287 mm  
Chamber Size: 13.90" X 20.98" X 11.30"

Power: 7kW  
Power: 9kW

#### SCS-5-208/240

Chamber Size: 353 × 533 × 435 mm  
Chamber Size: 13.90" X 20.98" X 17.13"

Power: 11.5kW  
Power: 15kW

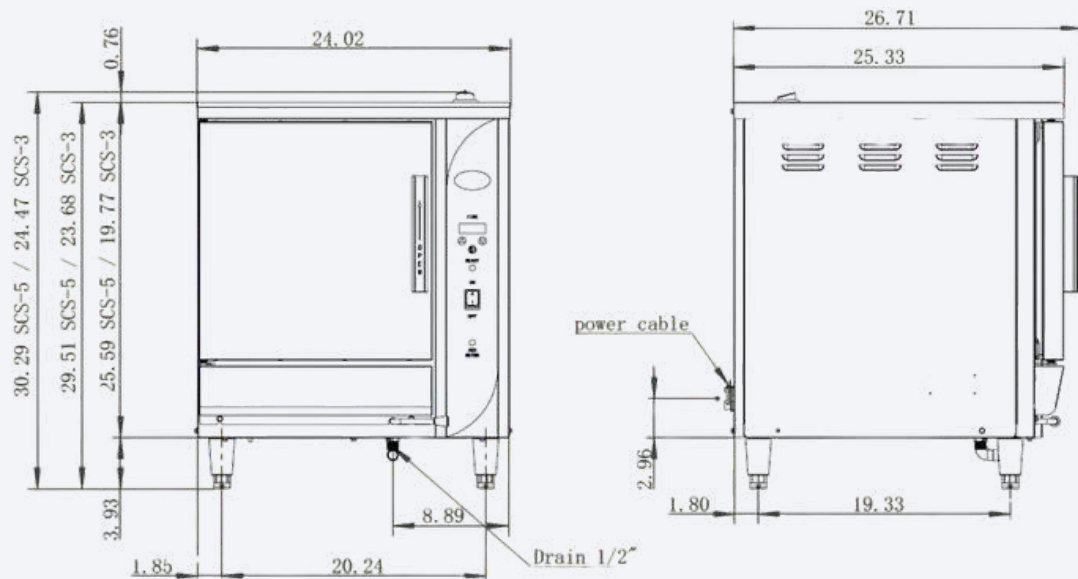

ENTREE LLC..

Tel: (704) 900 2068 E-mail: [solaris@entree.biz](mailto:solaris@entree.biz) Web: [www.entree.biz](http://www.entree.biz)



# Gas Range



ENTREE LLC..

Tel: (704) 900 2068 E-mail: [solaris@entree.biz](mailto:solaris@entree.biz) Web: [www.entree.biz](http://www.entree.biz)



## SR4-N-L / SR4-P-L SR4-N-C / SR4-P-C

### 24" Gas Range, 4 Open Burners and 1 Oven

#### Features

- Key components certified to CSA / ETL standards
- Gas appliance regulator included
- Gas conversion kit included to convert between Natural Gas and Propane
- Four 30,000 BTU cast iron burners with individual pilot lights
- Heavy-duty 12" x 12" removable cast iron grates
- Instant-light burners with adjustable control knobs
- 30,000 BTU oven burner
- Adjustable oven thermostat 250°F – 550°F (121°C – 288°C)
- Heavy-duty stainless steel construction
- 430 stainless steel oven liner
- Ceramic oven bottom for even heat distribution
- Two adjustable oven racks (removable)
- Compression spring oven door system with cool-touch handle
- Flame failure safety device
- 3/4" NPT rear gas connection
- Removable crumb tray under burners for easy cleaning
- 6" adjustable stainless steel legs
- Optional casters (front swivel with brake, rear swivel)
- For casters (standard) use "-C", for legs without casters use "-L"

Size(W\*D\*H):609.4X829.7X1532.3mm  
 Size(W\*D\*H): 23.99"X32.67"X60.33"  
 N.W. : 129kg G.W. : 161.5kg  
 N.W. : 284.40lbs G.W. : 356.12 lbs  
 Gas consumption(m<sup>3</sup>/h):  
 NG: 3.946 / LPG: 1.699

Quantity of Burners: 4  
 Quantity of Controls: 5  
 Quantity of Racks: 2  
 Burner Power(BTU): 30,000X4  
 Oven Power(BTU) :30,000X1  
 Total Power(BTU): 150,000

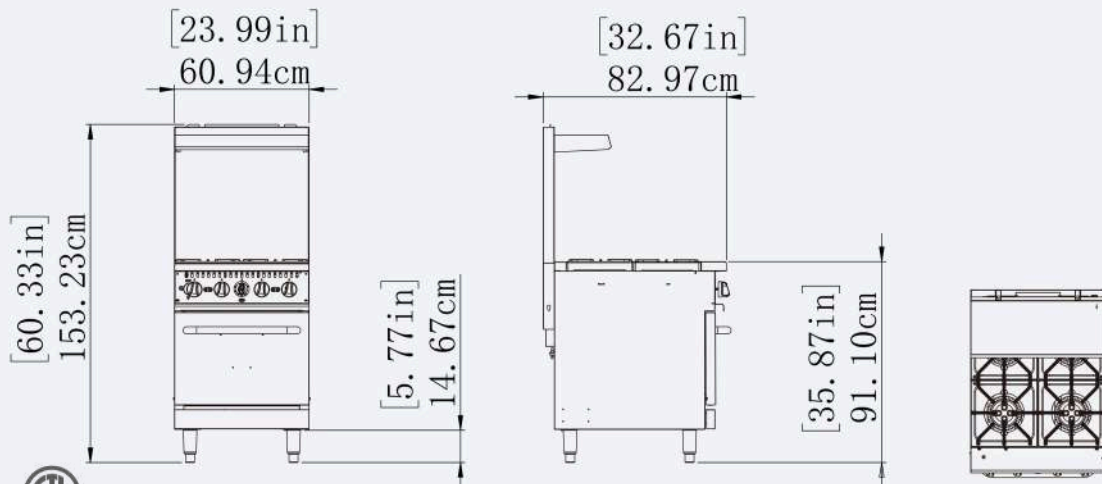

\* All above parameters for reference only,take practicality as standard.



## SR6-N-L / SR6-P-L SR6-N-C / SR6-P-C

### 36" Gas Range, 6 Open Burners and 1 Oven.

#### Features

- CSA / ETL certified components Gas appliance regulator included
- Gas conversion kit included for Natural Gas or Propane operation
- Six 30,000 BTU cast iron burners with individual pilot lights
- Heavy-duty 12" x 12" removable cast iron grates
- Instant-light burners with adjustable control knobs
- 30,000 BTU oven burner
- Adjustable oven thermostat 250°F – 550°F (121°C – 288°C)
- Heavy-duty stainless steel construction
- 430 stainless steel oven liner
- Ceramic oven bottom for even heat distribution
- Two adjustable removable oven racks
- Compression spring oven door system with cool-touch handle
- Flame failure safety device
- Removable crumb tray under burners for easy cleaning
- 3/4" NPT rear gas connection
- 6" adjustable stainless steel legs
- Optional casters (front swivel with brake, rear swivel)
- For casters (standard) use "-C", for legs without casters use "-L"

Size(W\*D\*H): 908.8X829.7X1532.9mm  
 Size(W\*D\*H): 35.78"X32.67"X60.35"  
 N.W. : 170kg G.W. : 204kg  
 N.W. : 374.79 lbs G.W. : 449.7 lbs  
 Gas consumption(m<sup>3</sup>/h):  
 NG: 5.524 / LPG: 2.379

Quantity of Burners: 6  
 Quantity of Controls: 7  
 Quantity of Racks: 2  
 Burner Power(BTU): 30,000X6  
 Oven Power(BTU): 30,000X1  
 Total Power(BTU): 210,000

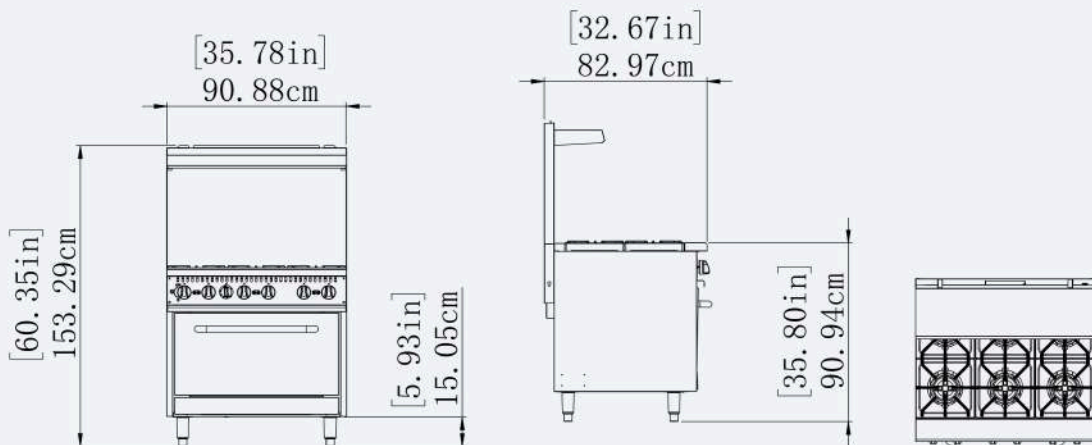

\* All above parameters for reference only, take practicality as standard.



SR10-N-L / SR10-P-L

SR10-N-C / SR10-P-C

**60" Gas Range, 10 Open Burners and 2 Ovens**

## Features

- CSA / ETL certified components
- Gas appliance regulator included
- Gas conversion kit included for Natural Gas or Propane operation
- Ten 30,000 BTU cast iron burners with individual pilot lights
- Heavy-duty 12" x 12" removable cast iron grates
- Instant-light burners with adjustable control knobs
- Two 30,000 BTU oven burners
- Adjustable oven thermostat 250°F – 550°F (121°C – 288°C)
- Heavy-duty stainless steel construction
- 430 stainless steel oven liners
- Ceramic oven bottoms for even heat distribution
- Two adjustable removable oven racks per oven
- Compression spring oven door system with cool-touch handles
- Flame failure safety device
- Removable crumb tray under burners for easy cleaning
- ¾" NPT rear gas connection
- 6" adjustable stainless steel legs
- Optional casters (front swivel with brake, rear swivel)
- For casters (standard) use "-C", for legs without casters use "-L"

Size(W\*D\*H): 1524X828.7X1532.9mm

Size(W\*D\*H): 60"X32.63"X60.35"

N.W. : 290.5kg G.W. : 348kg

Gas consumption(m<sup>3</sup>/h):

NG: 9.469 / LPG: 4.079

Quantity of Burners: 10

Quantity of Controls: 12

Quantity of Racks: 4

Burner Power(BTU): 30,000X10

Oven Power(BTU): 30,000X2

Total Power(BTU): 360,000

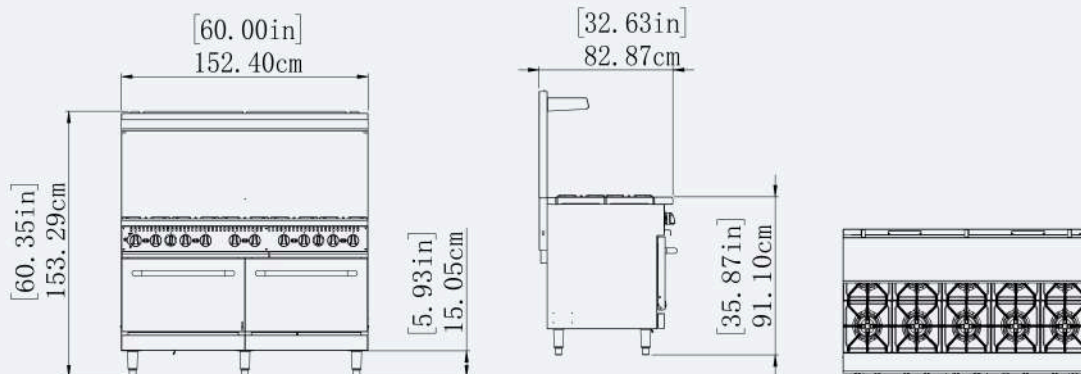

\* All above parameters for reference only, take practicality as standard.

ENTREE LLC..

Tel: (704) 900 2068 E-mail: solaris@entree.biz Web: www.entree.biz



### SR6-G12-N-L / SR6-G12-P-L SR6-G12-N-C / SR6-G12-P-C

**36" Gas Range, 4 Open Burners,  
12" Griddle and 1 Oven.**

### Features

- Key components have CSA / ETL certificate.
- 6" adjustable stainless steel legs and back shelf can be removed when packing to reduce transportation cost.
- Equipped with regulator.
- Gas convert kit to exchange the gas type.
- Heavy-duty cast iron lift-off grates for easy cleaning.
- Adjustable thermostat from 250°F-550°F or 121°C-288°C.
- Optional Casters Available, front swivel with brake, rear swivel.
- For casters (standard) use "-C", for legs without casters use "-L"

Size(W\*D\*H): 914.4X827.5X1532.9mm  
 Size(W\*D\*H): 36"X32.58"X60.35"  
 N.W. : 187.5kg G.W. : 225kg  
 N.W. : 413.4 lbs G.W. : 496.0 lbs  
 Gas consumption(m³/h):  
 NG: 4.472 / LPG: 1.926  
 Plate Thickness:0.75"(19mm)

Quantity of Burners: 4  
 Quantity of Controls: 5  
 Quantity of Racks: 2  
 Burner Power(BTU): 30,000X4  
 Oven Power(BTU): 30,000X1  
 Griddle Power(BTU): 20,000X1  
 Total Power(BTU):170,000

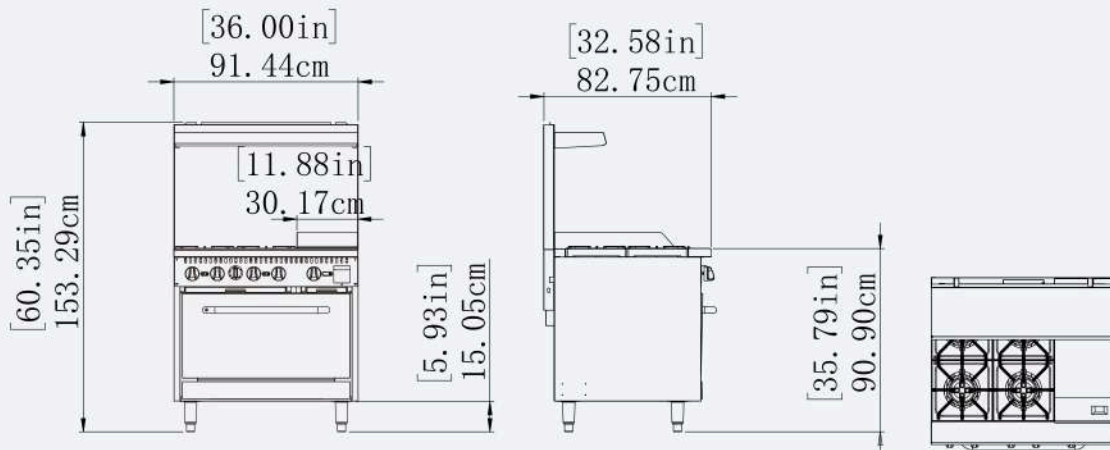

\* All above parameters for reference only, take practicality as standard.



SR6-G24-N-L / SR6-G24-P-L  
SR6-G24-N-C / SR6-G24-P-C  
**GasRange/Griddle Combos**

## Features

- Key components have CSA / ETL certificate.
- 6" adjustable stainless steel legs and back shelf can be removed when packing to reduce transportation cost.
- Equipped with regulator.
- Gas convert kit to exchange the gas type.
- Heavy-duty cast iron lift-off grates for easy cleaning.
- Adjustable thermostat from 250°F-550°F or 121°C-288°C.
- Optional Casters Available, front swivel with brake, rear swivel.
- For casters (standard) use "-C", for legs without casters use "-L"

Size(W\*D\*H): 911.6X827.7X1532.9mm  
Size(W\*D\*H): 35.89X"32.59"X60.35"  
N.W. : 195kg G.W. : 231kg  
N.W. : 429.9 lbs G.W. : 509.5 lbs  
Gas consumption(m<sup>3</sup>/h):  
NG: 3.42 / LPG: 1.473  
Plate Thickness:0.75"(19mm)

Quantity of Burners: 2  
Quantity of Controls: 5  
Quantity of Racks: 2  
Burner Power(BTU): 30,000X2  
Oven Power(BTU): 30,000X1  
Griddle Power(BTU): 20,000X2  
Total Power(BTU): 130,000

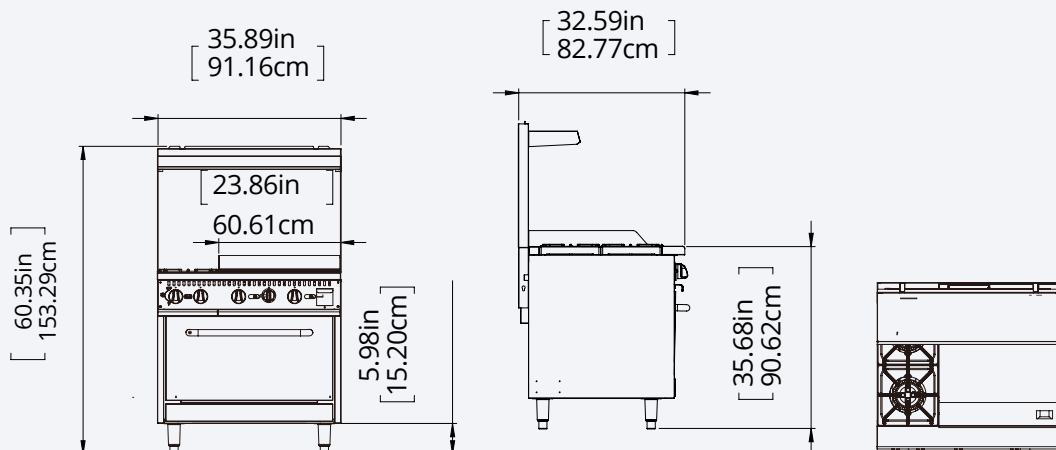

All above parameters for reference only, take practicality as standard.

\*



SR10-G24-N-L / SR10-G24-P-L  
SR10-G24-N-C / SR10-G24-P-C

**60" Gas Range, 6 Open Burners,  
24" Griddle and 2 Ovens**

**Features**

- Key components have CSA / ETL certificate.
- 6" adjustable stainless steel legs and back shelf can be removed when packing to reduce transportation cost.
- Equipped with regulator.
- Gas convert kit to exchange the gas type.
- Heavy-duty cast iron lift-off grates for easy cleaning.
- Adjustable thermostat from 250°F-550°F or 121°C-288°C.
- Optional Casters Available, front swivel with brake, rear swivel.
- Model number for casters SR10-G24-N-C / SR10-G24-P-C
- For casters (standard) use "-C", for legs without casters use "-L"

Size(W\*D\*H): 1518.4X827.1X1532.9mm  
Size(W\*D\*H): 59.78"X32.56"X60.35"  
N.W. : 312kg G.W. : 362kg  
N.W. : 687.7 lbs G.W. : 798.3 lbs  
Gas consumption(m³/h):  
NG: 7.365 / LPG: 3.172  
Plate Thickness:0.75"(19mm)

Quantity of Burners: 6  
Quantity of Controls: 10  
Quantity of Racks: 4  
Burner Power(BTU): 30,000X6  
Oven Power(BTU): 30,000X2  
Griddle Power(BTU): 20,000X2  
Total Power(BTU): 280,000

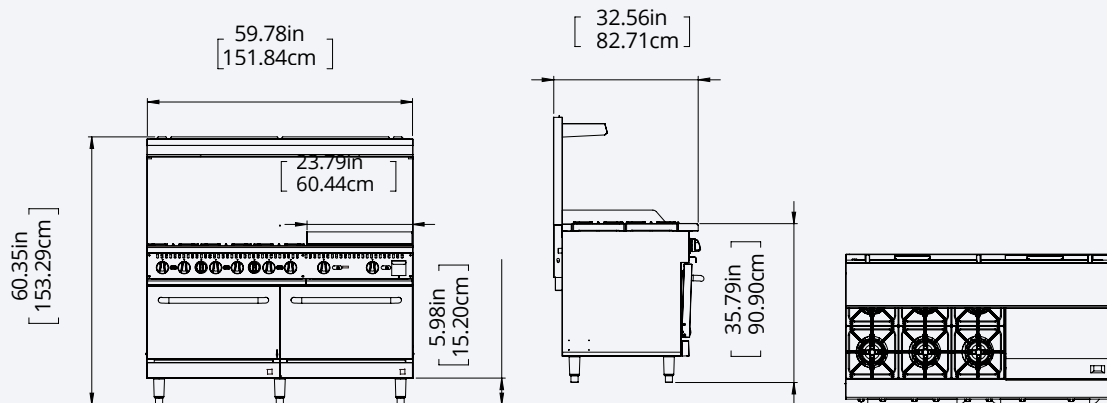

\* All above parameters for reference only,take practicality as standard.



SR10-N-L / SR10-P-L

SR10-N-C /SR10-P-C

**60" Gas Range, 6 Open Burners, 24" Raised/Griddle Broiler and 2 Ovens**

## Features

- Key components have CSA / ETL certificate.
- 6" adjustable stainless steel legs and back shelf can be removed
- when packing to reduce transportation cost.
- Equipped with regulator.
- Gas convert kit to exchange the gas type.
- Heavy-duty cast iron lift-off grates for easy cleaning.
- Adjustable thermostat from 250°F-550°F or 121°C-288°C.
- Optional Casters Available, front swivel with brake, rear swivel.
- Model number for casters SR10-N-C /SR10-P-C
- For casters (standard) use "-C", for legs without casters use "-L"

Size(W\*D\*H): 1524X829.2X1532.9mm

Size(W\*D\*H): 60"X32.65"X60.35"

N.W. : 331.5kg G.W. : 387kg

N.W. : 730.8 lbs G.W. : 853.4 lbs

Gas consumption(m<sup>3</sup>/h):

NG: 7.26 / LPG: 3.127

Plate Thickness:0.75"(19mm)

Quantity of Burners: 6

Quantity of Controls: 11

Quantity of Racks: 4

Burner Power(BTU): 30,000X6

Oven Power(BTU): 30,000X2

Griddle/Salamander Power(BTU): 12,000X3

Total Power(BTU): 276,000

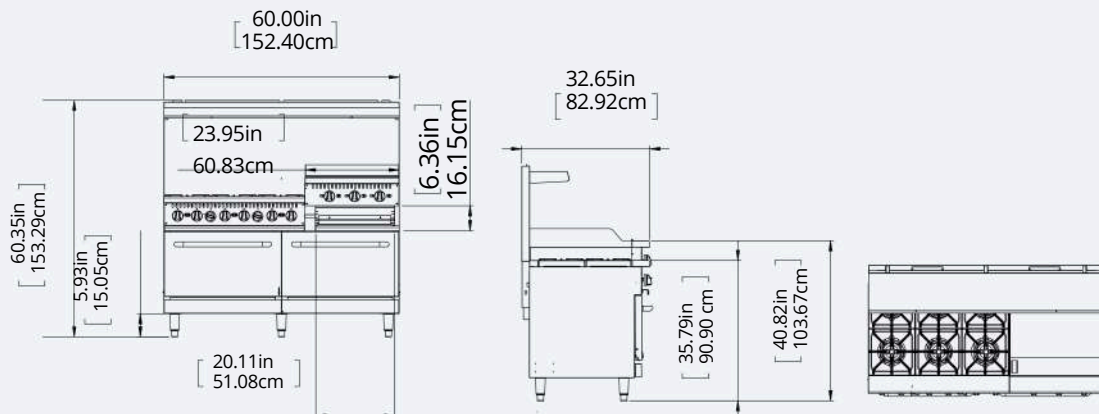

\* All above parameters for reference only,take practicality as standard.

ENTREE LLC..

Tel: (704) 900 2068 E-mail: solaris@entree.biz Web: www.entree.biz



# GAS FRYER





## Gas Fryer

### Features

- Key components have CSA / ETL certificate.
- 6" adjustable stainless steel legs can be removed when packing to reduce transportation cost.
- Adjustable thermostat from 200°F - 400°F or 93°C–204°C
- Optional Casters available.
- For casters (standard) use "-C", for legs without casters use "-L"

SF3-N-L / SF3-P-L  
SF3-N-C / SF3-P-C

Size(W\*D\*H): 395X765X1162mm  
Size(W\*D\*H): 15.57"X30.12"X45.75"  
N.W. : 61kg G.W : 73 kg  
N.W. : 134.48 lbs G.W : 160.94 lbs  
Gas consumption(m<sup>3</sup>/h):  
NG: 2.367 / LPG: 1.02

Capacity: 18.5-23L Quantity  
of Fryer Baskets: 2 Quantity  
of Tube Burners: 3  
Power(BTU): 30,000X3

SF4-N-L / SF4-P-L  
SF4-N-C / SF4-P-C

Size(W\*D\*H): 395X765X1162mm  
Size(W\*D\*H): 15.57"X30.12"X45.75"  
N.W. : 66kg G.W. : 78kg  
N.W. : 145.50lbs 171.96lbs  
Gas consumption(m<sup>3</sup>/h):  
NG: 3.156 / LPG: 1.36

Capacity: 21.3-25L Quantity  
of Fryer Baskets: 2 Quantity  
of Tube Burners: 4  
Power(BTU): 30,000X4

SF5-N-L /SF5-P-L  
SF5-N-C /SF5-P-C

Size(W\*D\*H): 533X765X1162mm  
Size(W\*D\*H): 21"X30.12"X45.75"  
N.W. : 75kg G.W. : 93kg  
N.W. :165.35lbs N.W.: 205.03lbs  
Gas consumption(m<sup>3</sup>/h):  
NG: 3.946 / LPG: 1.7

Capacity: 31-37L Quantity  
of Fryer Baskets: 2 Quantity  
of Tube Burners: 5  
Power(BTU): 30,000X5



All above parameters for reference only,take practicality as standard.

ENTREE LLC.

Tel: (704) 900 2068 E-mail: solaris@entree.biz Web: www.entree.biz



## Gas Energy-Star Fryer

### Features

- ENERGY STAR® , ETL safety and ETL sanitation certified.
- Robert shaw brand key components.
- Millivolt thermostat control adjusts from 200°F to 400°F or 93°C–204°C
- The temperature of the ledge and panel is cool.
- 6 inch adjustable legs, casters available.
- For casters (standard) use "-C", for legs without casters use "-L"

SFES3-N-L / SFES3-P-L  
SFES3-N-C / SFES3-P-C

Size(W\*D\*H): 394X762X1243mm  
Size(W\*D\*H): 15.5"X30.02"X48.94"  
Capacity: 15.88 KG  
Capacity: 35LBS

Quantity of Fryer Baskets: 2  
Quantity of Tube Burners: 3  
Power(BTU): 65,000

SFES4-N-L / SFES4-P-L  
SFES4-N-C / SFES4-P-C

Size(W\*D\*H): 394X762X1243mm  
Size(W\*D\*H): 15.5"X30.02"X48.94"  
Capacity: 20.41 KG  
Capacity: 45LBS

Quantity of Fryer Baskets: 2  
Quantity of Tube Burners: 4  
Power(BTU): 84,000

SFES5-N-L / SFES5-P-L  
SFES5-N-C / SFES5-P-C

Size(W\*D\*H): 533X762X1243mm  
Size(W\*D\*H): 20.98"X30.02"X48.94"  
Capacity: 27.22 KG  
Capacity: 60LBS

Quantity of Fryer Baskets: 2  
Quantity of Tube Burners: 5  
Power(BTU): 105,000



\*All above parameters for reference only, take practicality as standard.



# Convection Oven Series





## Gas Convection Oven

### Features

- ETL Safety and ETL Sanitation certification approved.
- Key components has CSA/UL certificate.
- Italy brand FIR motor.
- American brand Resideo control valve.
- Temperature range is 150F~500F or 66°C–288°C.
- Long legs can be removed when packing to reduce transportation cost.
- Standard oven interior depth (29" wide x 21.5" deep)
- Single deck casters available, all swivel, front locking.
- Optional Casters Available, front swivel with brake, rear swivel.
- For casters (standard) use "-C", for legs without casters use "-L"

**SCO1-N-L / SCO1-P-L  
SCO1-N-C / SCO1-P-C**

Overall Size(W\*D\*H): 968×1058×1434mm  
 Overall Size(W\*D\*H): 38.11" x41.65" x56.46"  
 Chamber Size(W\*D\*H): 737×546×508mm  
 Chamber Size(W\*D\*H): 29" x21.5" x20"  
 Rack Size(W\*D): 711×523mm  
 Rack Size(W\*D): 28"x20.6"  
 Power: 60,000 BTU/H Burner qty: 4

Voltage:120V/60HZ/1PH  
 NW:507LBS GW:569LBS  
 Gas consumption(m3/h):NG:  
 1.578/LPG:0.68  
 Motor Speed: 1710(H)/1120(L)

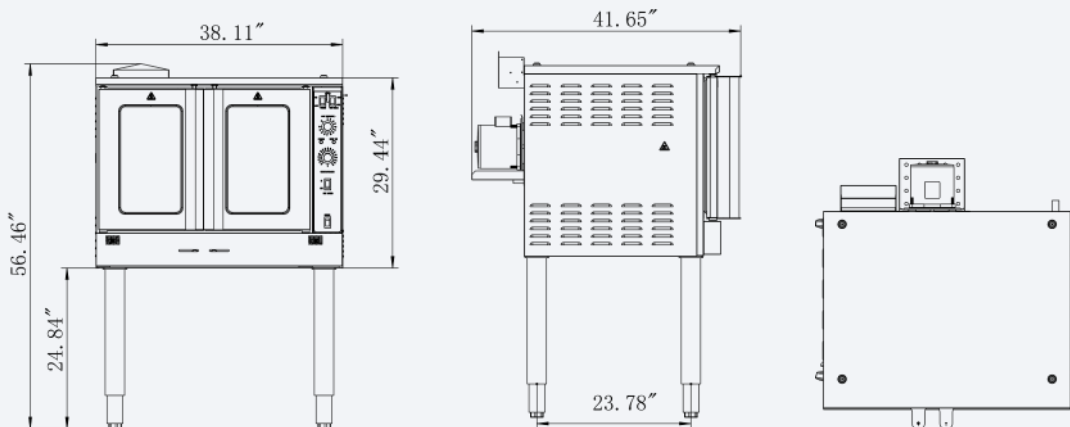

All above parameters for reference only, take practicality as standard.



## Double-layer Gas Convection Oven

### Features

- ETL Safety and ETL Sanitation certification approved.
- Key components has CSA/UL certificate.
- Italy brand FIR motor.
- American brand Resideo control valve.
- Temperature range is 150F~500F or 66°C~260°C.
- All ovens shipped as single deck ovens.
- Purchase "Stacking Kit" to make oven stackable as seen in photo.
- Stacking Kit comes standard with casters as shown)
- Optional Casters Available, front swivel with brake, rear swivel.
- For casters (standard) use "-C", for legs without casters use "-L"

SCO1B-N-L / SCO1B-P-L  
SCO1B-N-C / SCO1B-P-C

Overall Size(W\*D\*H): 968×1058×1723mm  
Overall Size(W\*D\*H): 38.11" x41.65" x67.83"  
Chamber Size(W\*D\*H): 737×546×508mm  
Chamber Size(W\*D\*H): 29" x21.5" x20"  
Rack Size(W\*D): 711×523mm  
Rack Size(W\*D): 28"x20.6"  
Power: 60,000\*2 BTU/H

Burner qty: 4\*2  
Voltage:120V/60HZ/1PH  
Motor Speed: 1710(H)/1120(L)

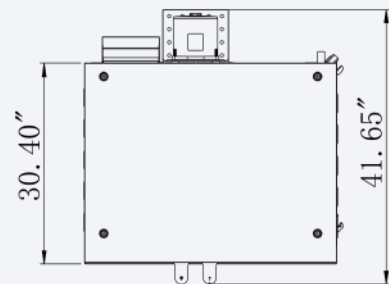
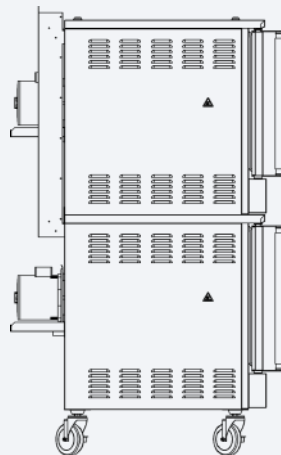
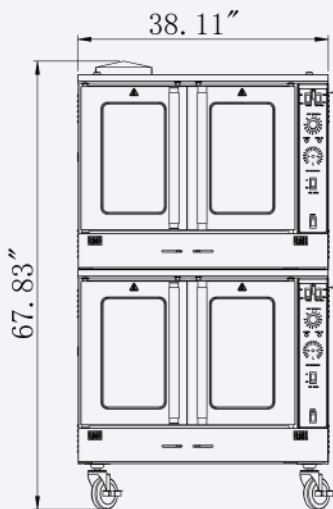

All above parameters for reference only,take practicality as standard.

ENTREE LLC.

Tel: (704) 900 2068 E-mail: solaris@entree.biz Web: www.entree.biz



# Heavy Duty Series



ENTREE LLC.

Tel: (704) 900 2068 E-mail: [solaris@entree.biz](mailto:solaris@entree.biz) Web: [www.entree.biz](http://www.entree.biz)



## Stock Pot Range

### Features

- CSA / ETL certified components
- 6" adjustable stainless steel legs
- Equipped with 3/4" inlet gas pipe and convertible pressure regulator
- Gas conversion kit for Natural Gas or Propane operation
- Heavy-duty cast iron lift-off grates for easy cleaning
- SHS-1 includes two burner controls
- SHS-1D includes four burner controls
- Heavy-duty construction

#### SHS-1-N / SHS-1-P

Size(W\*D\*H): 460X508.25X502mm  
 Size(W\*D\*H): 18.11"X20.01"X19.75"  
 N.W. : 44kg G.W. : 52kg  
 N.W. : 97.0 lbs G.W. : 114.6 lbs  
 Gas consumption(m<sup>3</sup>/h):  
 NG: 1.999 / LPG: 0.567

Quantity of Burners: 1  
 Quantity of Controls: 2  
 Power(BTU):  
 NG: 76,000X1 / LPG:50,000X1

#### SHS-1D-N / SHS-1D-P

Size(W\*D\*H): 460X1068X541.5mm  
 Size(W\*D\*H): 18.11"X42.05"X21.32"  
 N.W. : G.W. :  
 N.W. : G.W. :  
 Gas consumption(m<sup>3</sup>/h):  
 NG: 3.998 / LPG: 1.133

Quantity of Burners: 2  
 Quantity of Controls: 2  
 Power(BTU):  
 NG: 76,000X2 / LPG: 50,000X2

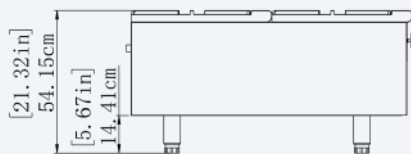
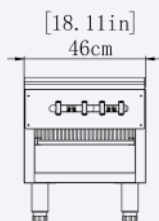

All above parameters for reference only, take practicality as standard.

ENTREE LLC.

Tel: (704) 900 2068 E-mail: solaris@entree.biz Web: www.entree.biz



## Gas Countertop Hotplates

### Features

- Key components have CSA / ETL certification
- 4" adjustable stainless steel legs
- Equipped with convertible appliance regulator (maximum pressure ½ P.S.I.)
- Gas conversion kit included to convert to appropriate incoming gas
- Heavy-duty one-piece cast iron lift-off grates for easy cleaning
- Full-width crumb tray easily removable for cleaning
- Infinite valve control
- 3/4" NPT rear gas connection
- Heavy-duty countertop burners

#### SHP-1229-N / SHP-1229-P

Size(W\*D\*H): 303X802X365mm  
Size(W\*D\*H): 12"X31.58"X14.35"  
N.W. : 30kg G.W. : 45.5kg  
N.W. : 66.1 lbs G.W. : 100.3 lbs  
Gas consumption(m<sup>3</sup>/h):  
NG: 1.578 / LPG: 0.68

Quantity of Burners: 2  
Quantity of Controls: 2  
Power(BTU): 30,000X2

#### SHP-2429-N / SHP-2429-P

Size(W\*D\*H): 603X802X365mm  
Size(W\*D\*H): 24"X31.58"X14.35"  
N.W. : 54.5kg G.W. : 69.5kg  
N.W. : 120.2 lbs G.W. : 153.2 lbs  
Gas consumption(m<sup>3</sup>/h):  
NG: 3.156 / LPG: 1.36

Quantity of Burners: 4  
Quantity of Controls: 4  
Power(BTU): 30,000X4

#### SHP-3629-N / SHP-3629-N

Size(W\*D\*H): 903X802X365mm  
Size(W\*D\*H): 36"X31.58"X14.35"  
N.W. : 84kg G.W. : 102kg  
N.W. : 185.2 lbs G.W. : 224.9 lbs  
Gas consumption(m<sup>3</sup>/h):  
NG: 4.735 / LPG: 2.04

Quantity of Burners: 6  
Quantity of Controls: 6  
Power(BTU): 30,000X6



All above parameters for reference only, take practicality as standard.

**ENTREE LLC.**

Tel: (704) 900 2068 E-mail: [solaris@entree.biz](mailto:solaris@entree.biz) Web: [www.entree.biz](http://www.entree.biz)



## Gas Countertop Griddle

### Features

- Key components have CSA / ETL certification
- 4" adjustable stainless steel legs
- Equipped with convertible appliance regulator (maximum pressure ½ P.S.I.)
- Gas conversion kit included to convert to appropriate incoming gas
- 5/8" thick steel griddle plate on 12", 18", 24", and 36" models for quick heat recovery
- 3/4" thick steel plate on 48", 60", and 72" models for even heating
- 3" side splash guards
- Removable grease container for easy cleaning
- Infinite valve control

#### SHDG-2433-N / SHDG-2433-P

Size(W\*D\*H): 612X836X442mm  
 Size(W\*D\*H): 24.11"X32.93"X17.39"  
 N.W. : 91kg G.W. : 107kg  
 N.W.: 200.6 lbs G.W.: 235.9 lbs  
 Gas consumption(m³/h):  
 NG: 1.578 / LPG: 0.68

Quantity of Burners: 2 Quantity of  
 Controls: 2 Cooking Surface:  
 23.86"X24.09" Plate Thickness:  
 20mm,0.79" Power(BTU): 30,000X2

#### SHDG-3633-N / SHDG-3633-P

Size(W\*D\*H): 917X836X442mm  
 Size(W\*D\*H): 36.11"X32.93"X17.39"  
 N.W. : 129kg G.W. : 154kg  
 N.W.: 284.4 lbs G.W.: 339.5 lbs  
 Gas consumption(m³/h):  
 NG: 2.367 / LPG: 1.02

Quantity of Burners: 3 Quantity of  
 Controls: 3 Cooking Surface:  
 35.87"X24.09" Plate Thickness:  
 20mm,0.79" Power(BTU): 30,000X3

#### SHDG-4833-N / SHDG-4833-P

Size(W\*D\*H): 1222X836X442mm  
 Size(W\*D\*H): 48.11"X32.93"X17.39"  
 N.W. : 169kg G.W. : 204kg  
 N.W.: 372.6 lbs G.W.: 449.7 lbs  
 Gas consumption(m³/h):  
 NG: 3.156 / LPG: 1.36

Quantity of Burners: 4 Quantity of  
 Controls: 4 Cooking Surface:  
 47.87"X24.09" Plate Thickness:  
 20mm,0.79" Power(BTU): 30,000X4



All above parameters for reference only, take practicality as standard.



## Gas Thermostatic Griddle

### Features

- Key components have CSA / ETL certification
- 4" adjustable stainless steel legs
- Equipped with convertible appliance regulator (maximum pressure ½ P.S.I.)
- Gas conversion kit included to convert to appropriate incoming gas
- 3/4" thick hot rolled steel griddle plate for fast heat recovery and even heating
- 4" back and side splash guards
- Removable grease container for easy cleaning
- Infinite valve control
- Thermostatic temperature range from 200°F to 450°F (93°C–232°C)

#### SHDGT-2433-N / SHDGT-2433-P

Size(W\*D\*H): 612X836X442mm  
 Size(W\*D\*H): 24.11"X32.93"X17.39"  
 N.W. : 91kg G.W. : 107kg  
 N.W.: 200.6 lbs G.W.: 235.9 lbs  
 Gas consumption(m<sup>3</sup>/h):  
 NG: 1.578 / LPG: 0.68

Quantity of Burners: 2 Quantity of  
 Controls: 2 Cooking Surface:  
 23.86"X24.09" Plate Thickness:  
 20mm,0.79" Power(BTU): 30,000X2

#### SHDGT-3633-N / SHDGT-3633-P

Size(W\*D\*H): 917X836X442mm  
 Size(W\*D\*H): 36.11"X32.93"X17.39"  
 N.W. : 129kg G.W. : 154kg  
 N.W.: 284.4 lbs G.W.: 339.5 lbs  
 Gas consumption(m<sup>3</sup>/h):  
 NG: 2.367 / LPG: 1.02

Quantity of Burners: 3 Quantity of  
 Controls: 3 Cooking Surface:  
 35.87"X24.09" Plate Thickness:  
 20mm,0.79" Power(BTU): 30,000X3

#### SHDGT-4833-N / SHDGT-4833-P

Size(W\*D\*H): 1222X836X442mm  
 Size(W\*D\*H): 48.11"X32.93"X17.39"  
 N.W. : 169kg G.W. : 204kg  
 N.W.: 372.6 lbs G.W.: 449.7 lbs  
 Gas consumption(m<sup>3</sup>/h): NG: 3.156 /  
 LPG: 1.36

Quantity of Burners: 4 Quantity of  
 Controls: 4 Cooking Surface:  
 47.87"X24.09" Plate Thickness:  
 20mm,0.79" Power(BTU): 30,000X4



All above parameters for reference only, take practicality as standard.



## Gas Countertop Charbroiler

### Features

- Key components have CSA / ETL certification
- 4" adjustable stainless steel legs
- Equipped with convertible appliance regulator (maximum pressure ½ P.S.I.)
- Gas conversion kit included to convert to appropriate incoming gas
- Reversible cast iron grill grates with adjustable height
- 4" back and side splash guards
- Full-width crumb tray easily removable for cleaning
- Infinite valve control
- 3/4" NPT rear gas connection

#### SHDB-1430-N / SHDB-1430-P

Size(W\*D\*H): 356X774X469mm  
 Size(W\*D\*H): 14"X30.47"X18.46"  
 N.W. : 58kg G.W. : 60kg  
 N.W.: 127.9 lbs G.W.: 132.3 lbs  
 Gas consumption(m<sup>3</sup>/h):  
 NG: 1.052 / LPG: 0.453

Quantity of Burners: 2  
 Quantity of Controls: 2  
 Power(BTU): 20,000X2

#### SHDB-2430-N / SHDB-2430-P

Size(W\*D\*H): 610X772.8X469.1mm  
 Size(W\*D\*H): 24.02"X30.43"X18.47"  
 N.W. : 90kg G.W. : 116kg  
 N.W.: 198.4 lbs G.W.: 255.7 lbs  
 Gas consumption(m<sup>3</sup>/h):  
 NG: 2.104 / LPG: 0.906

Quantity of Burners: 4  
 Quantity of Controls: 4  
 Power(BTU): 20,000X4

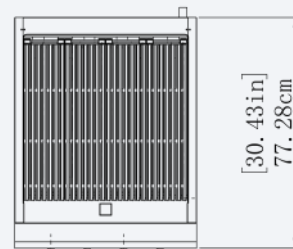
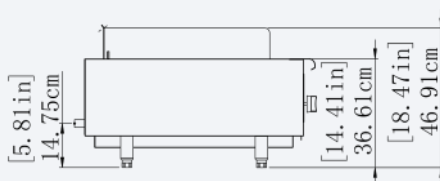
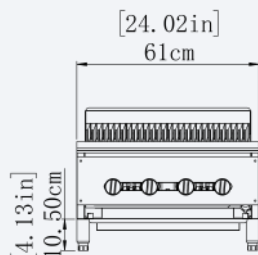

All above parameters for reference only, take practicality as standard.

ENTREE LLC.

Tel: (704) 900 2068 E-mail: solaris@entree.biz Web: www.entree.biz



BRS-3629-N/P

BRS-4829-N/P

### Gas Countertop Charbroiler

### Features

- Key components have CSA / ETL certificate
- 4" adjustable stainless steel legs (removed for packaging to prevent concealed damage and lower shipping costs)
- Equipped with convertible appliance regulator (Maximum pressure 1/2 P.S.I.)
- Gas conversion kit shipped standard to convert to appropriate incoming gas
- Cast iron grill grates are reversible
- 4" back and side splash guards
- Full width crumb tray easily removed for cleaning
- Infinite valve control
- 3/4" NPT rear gas connection

#### SHDB-3630-N / SHDB-3630-P

Size(W\*D\*H): 915X774X469mm  
 Size(W\*D\*H): 36"X30.47"X18.46"  
 N.W. : 138kg G.W. : 165kg  
 N.W.: 304.2 lbs G.W.: 363.8 lbs  
 Gas consumption(m<sup>3</sup>/h):  
 NG: 3.156 / LPG: 1.36

Quantity of Burners: 6  
 Quantity of Controls: 6  
 Power(BTU): 20,000X6

#### SHDB-4830-N / SHDB-4830-P

Size(W\*D\*H): 1223.2X774.1X467.8mm  
 Size(W\*D\*H): 48.16"X30.48"X18.42"  
 N.W. : 178kg G.W. : 208kg  
 N.W.: 392.4 lbs G.W.: 458.6 lbs  
 Gas consumption(m<sup>3</sup>/h):  
 NG: 4.208 / LPG: 1.812

Quantity of Burners: 8  
 Quantity of Controls: 8  
 Power(BTU): 20,000X8

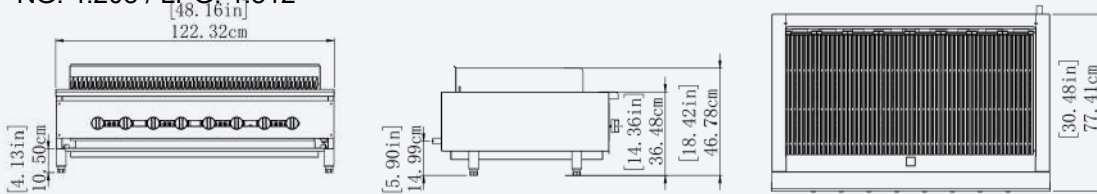

All above parameters for reference only, take practicality as standard.



# Medium Duty Series



ENTREE LLC.

Tel: (704) 900 2068 E-mail: [solaris@entree.biz](mailto:solaris@entree.biz) Web: [www.entree.biz](http://www.entree.biz)



## Gas Countertop Hotplates

### Features

- Medium duty countertop burners
- Key components have CSA / ETL certificate
- 4" adjustable stainless steel legs (removed for packaging to prevent concealed damage and lower shipping costs)
- Equipped with convertible appliance regulator (Maximum pressure ½ P.S.I.)
- Gas conversion kit shipped standard to convert to appropriate incoming gas
- Heavy duty 12" square cast iron lift-off top grates for easy cleaning
- Full width crumb tray easily removed for cleaning
- Infinite valve control
- 3/4" NPT rear gas connection

#### *SHP-1229-N / SHP-1229-P*

Size(W\*D\*H): 304.5X738X334.9mm  
 Size(W\*D\*H): 11.99"X29.05"X13.19"  
 N.W. : 29.5kg G.W. : 43kg  
 N.W.: 65.0 lbs G.W.: 94.8 lbs  
 Gas consumption(m<sup>3</sup>/h):  
 NG: 1.578 / LPG: 0.68

Quantity of Burners: 2  
 Quantity of Controls: 2  
 Power(BTU): 30,000X2

#### *SHP-2429-N / SHP-2429-P*

Size(W\*D\*H): 609.5X738X344.9mm  
 Size(W\*D\*H): 24"X29.05"X13.19" N.W. :  
 51kg G.W. : 70.5kg  
 N.W.: 112.4 lbs G.W.: 155.4 lbs  
 Gas consumption(m<sup>3</sup>/h):  
 NG: 3.156 / LPG: 1.36

Quantity of Burners: 4  
 Quantity of Controls: 4  
 Power(BTU): 30,000X4

#### *SHP-3629-N / SHP-3629-N*

Size(W\*D\*H): 914.6X738X334.9mm  
 Size(W\*D\*H): 36.01"X29.05"X13.19"  
 N.W. : 77kg G.W. : 100.5kg  
 N.W.: 169.8 lbs G.W.: 221.6 lbs  
 Gas consumption(m<sup>3</sup>/h):  
 NG: 4.735 / LPG: 2.04

Quantity of Burners: 6  
 Quantity of Controls: 6  
 Power(BTU): 30,000X6



All above parameters for reference only, take practicality as standard.

**ENTREE LLC.**

Tel: (704) 900 2068 E-mail: [solaris@entree.biz](mailto:solaris@entree.biz) Web: [www.entree.biz](http://www.entree.biz)



## Gas Countertop Griddle

### Features

- Key components have CSA / ETL certificate
- 4" adjustable stainless steel legs (removed for packaging to prevent concealed damage and lower shipping costs)
- Equipped with convertible appliance regulator (Maximum pressure 1/2 P.S.I.)
- Gas conversion kit shipped standard to convert to appropriate incoming gas
- 1" thick hot rolled steel plate for quick recovery and even heating
- 4" back and 3" side splash guards
- Grease container easily removed for cleaning
- Infinite valve control
- Medium duty griddle

#### SGR-2429-N / SGR-2429-P

Size(W\*D\*H): 609.8X738X334.5mm  
 Size(W\*D\*H): 24.01"X29.06"X13.17"  
 N.W. : G.W. :  
 Gas consumption(m<sup>3</sup>/h):  
 NG: 1.578 / LPG: 0.68

Quantity of Burners: 2  
 Quantity of Controls: 2  
 Cooking Surface:23.87"X22.1"  
 Plate Thickness: 1"  
 Power(BTU): 30,000X2

#### SGR-3629-N/ SGR-3629-P

Size(W\*D\*H): 909.8X738X334.5mm  
 Size(W\*D\*H): 35.82"X29.06"X13.17"  
 N.W. : G.W. :  
 Gas consumption(m<sup>3</sup>/h):  
 NG: 2.367 / LPG: 1.02

Quantity of Burners: 3  
 Quantity of Controls: 3  
 Cooking Surface: 35.67"X22.1"  
 Plate Thickness: 1"  
 Power(BTU): 30,000X3

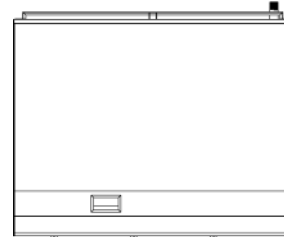
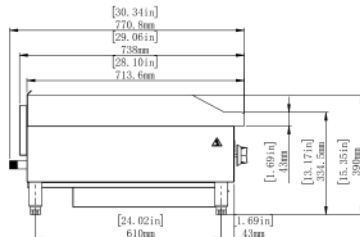
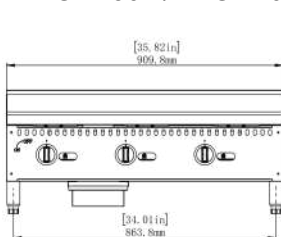

All above parameters for reference only, take practicality as standard.

## Gas Countertop Griddle

### Features

- Key components have CSA / ETL certificate
- 4" adjustable stainless steel legs (removed for packaging to prevent concealed damage and lower shipping costs)
- Equipped with convertible appliance regulator (Maximum pressure ½ P.S.I.)
- Gas conversion kit shipped standard to convert to appropriate incoming gas
- 1" thick hot rolled steel plate for quick recovery and even heating
- 4" back and 3" side splash guards
- Grease container easily removed for cleaning
- Infinite valve control
- Medium duty griddle



#### SGR-4829-N / SGR-4829-P

Size(W\*D\*H): 1210.4X738X334.5mm  
 Size(W\*D\*H): 47.65"X29.06"X13.17"  
 N.W. : G.W. :  
 Gas consumption(m³/h):  
 NG: 3.156 / LPG: 1.36

Quantity of Burners: 4  
 Quantity of Controls: 4  
 Cooking Surface: 47.48"X22.1"  
 Plate Thickness: 1"  
 Power(BTU): 30,000X4

#### SGR-6029-N / SGR-6029-P

Size(W\*D\*H): 1510.4X738X334.5mm  
 Size(W\*D\*H): 59.46"X29.06"X13.17"  
 N.W. : G.W. :  
 Gas consumption(m³/h):  
 NG: 3.946 / LPG: 1.7

Quantity of Burners: 5  
 Quantity of Controls: 5  
 Cooking Surface: 59.29"X22.1"  
 Plate Thickness: 1"  
 Power(BTU): 30,000X5

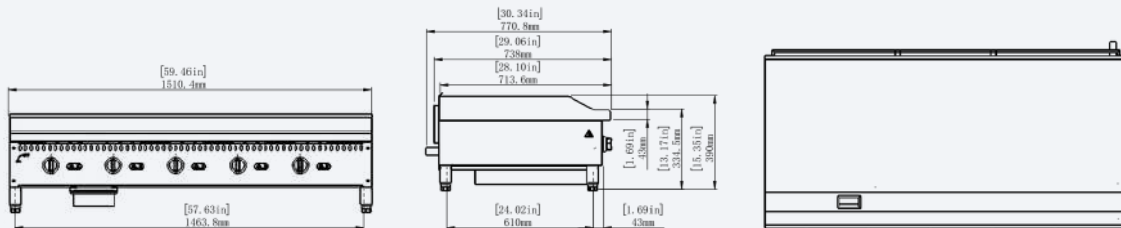

All above parameters for reference only, take practicality as standard.



## Gas Thermostatic Griddle

### Features



- Key components have CSA / ETL certificate
- 4" adjustable stainless steel legs (removed for packaging to prevent concealed damage and lower shipping costs)
- Equipped with convertible appliance regulator (Maximum pressure ½ P.S.I.)
- Gas conversion kit shipped standard to convert to appropriate incoming gas
- 1" thick hot rolled steel plate for quick recovery and even heating
- 4" back and 3" side splash guards
- Grease container easily removed for cleaning
- Thermostat control, temperature range 200°F to 450°F
- Medium duty thermostat griddle

#### SGRT-2429-N / SGRT-2429-P

Size(W\*D\*H): 609.8X738X334.5mm  
 Size(W\*D\*H): 24.01"X29.06"X13.17"  
 N.W. : 90.5kg G.W. : 110.5kg  
 N.W.: 199.6 lbs G.W.: 243.6 lbs  
 Gas consumption(m<sup>3</sup>/h):  
 NG: 1.578 / LPG: 0.68

Quantity of Burners: 2 Quantity of  
 Controls: 2 Cooking Surface:  
 23.86"X22.21" Plate Thickness: 1"  
 Power(BTU): 30,000X2

#### SGRT-3629-N / SGRT-3629-P

Size(W\*D\*H): 909.8X738X334.5mm  
 Size(W\*D\*H): 35.82"X29.06"X13.17"  
 N.W. : 129.5kg G.W. : 156kg  
 N.W.: 285.6 lbs G.W.: 343.9 lbs  
 Gas consumption(m<sup>3</sup>/h):  
 NG: 2.367 / LPG: 1.02

Quantity of Burners: 3 Quantity of  
 Controls: 3 Cooking Surface:  
 35.67"X22.21" Plate Thickness: 1"  
 Power(BTU): 30,000X3

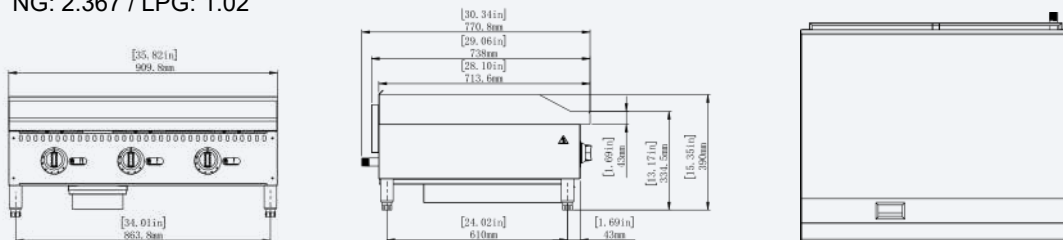

All above parameters for reference only, take practicality as standard.



## GRST-4829-N/P/GRST-6029-N/P

### Gas Thermostatic Griddle



### Features

- Key components have CSA / ETL certificate
- 4" adjustable stainless steel legs (removed for packaging to prevent concealed damage and lower shipping costs)
- Equipped with convertible appliance regulator (Maximum pressure 1/2 P.S.I.)
- Gas conversion kit shipped standard to convert to appropriate incoming gas
- 1" thick hot rolled steel plate for quick recovery and even heating
- 4" back and 3" side splash guards
- Grease container easily removed for cleaning
- Thermostat control, temperature range 200°F to 450°F
- Medium duty thermostat griddle

#### SGRT-4829-N / SGRT-4829-P

Size(W\*D\*H): 1210.4X738X334.5mm  
 Size(W\*D\*H): 47.65"X29.06"X13.17"

N.W. : 165kg G.W. : 196kg  
 N.W.: 363.8 lbs G.W.: 432.1 lbs  
 Gas consumption(m<sup>3</sup>/h):  
 NG: 3.156 / LPG: 1.36

Quantity of Burners: 4 Quantity of Controls: 4  
 Cooking Surface: 47.48"X22.21" Plate Thickness: 1"  
 Power(BTU): 30,000X4

#### SGRT-6029-N / SGRT-6029-P

Size(W\*D\*H): 1510.4X738X334.5mm  
 Size(W\*D\*H): 59.46"X29.06"X13.17" N.W. : 204.5kg  
 G.W. : 242.5kg  
 N.W.: 450.9 lbs G.W.: 534.7 lbs  
 Gas consumption(m<sup>3</sup>/h):  
 NG: 3.946 / LPG: 1.7

Quantity of Burners: 5 Quantity of Controls: 5  
 Cooking Surface: 59.29"X22.21" Plate Thickness: 1"  
 Power(BTU): 30,000X5

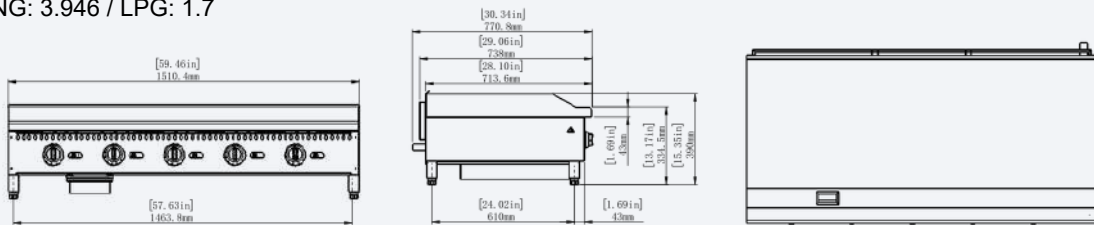

All above parameters for reference only, take practicality as standard.



## Gas Countertop Charbroiler

### Features

- Key components have CSA / ETL certificate
- 4" adjustable stainless steel legs (removed for packaging to prevent concealed damage and lower shipping costs)
- Equipped with convertible appliance regulator (Maximum pressure ½ P.S.I.)
- Gas conversion kit shipped standard to convert to appropriate incoming gas
- Cast iron grill grates are reversible
- 4" back and 3" side splash guards
- Full width crumb tray easily removed for cleaning
- Infinite valve control
- 3/4" NPT rear gas connection
- Medium duty charbroiler

#### SBR-1429-N / SBR-1429-P

Size(W\*D\*H): 355.6X738X334.5mm

Size(W\*D\*H): 14"X29.06"X13.17"

N.W. : G.W. :

Gas consumption(m<sup>3</sup>/h):

NG: 1.052 / LPG: 0.453

Quantity of Burners: 2

Quantity of Controls: 2

Power(BTU): 20,000X2

#### SBR-2429-N / SBR-2429-P

Size(W\*D\*H): 609.6x738x334.5mm

Size(W\*D\*H): 24"X29.06"X13.17"

N.W. : G.W. :

Gas consumption(m<sup>3</sup>/h):

NG: 2.104 / LPG: 0.906

Quantity of Burners: 4

Quantity of Controls: 4

Power(BTU): 20,000X4

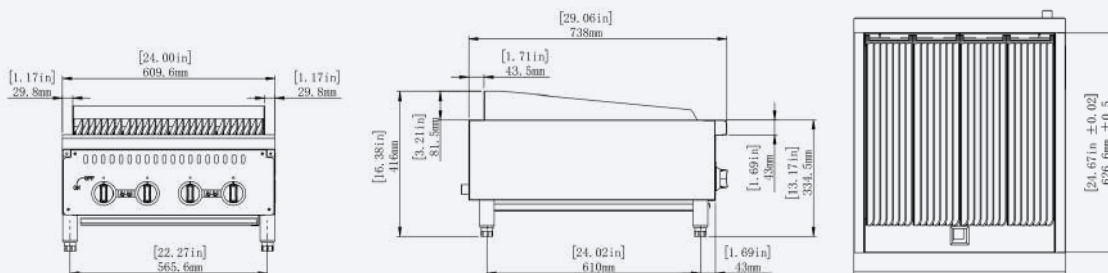

All above parameters for reference only, take practicality as standard.

ENTREE LLC.

Tel: (704) 900 2068 E-mail: solaris@entree.biz Web: www.entree.biz

## BRS-3629-N/P/BRS-4829-N/P

### Gas Countertop Charbroiler

#### Features



- Key components have CSA / ETL certificate
- 4" adjustable stainless steel legs (removed for packaging to prevent concealed damage and lower shipping costs)
- Equipped with convertible appliance regulator (Maximum pressure ½ P.S.I.)
- Gas conversion kit shipped standard to convert to appropriate incoming gas
- Cast iron grill grates are reversible
- 4" back and 3" side splash guards
- Full width crumb tray easily removed for cleaning
- Infinite valve control
- 3/4" NPT rear gas connection
- Medium duty charbroiler

#### SBR-3629-N / SBR-3629-P

Size(W\*D\*H): 914.5X738X334.5mm  
 Size(W\*D\*H): 36"X29.06"X13.17" N.W. :  
 124.5kg G.W. : 150kg  
 N.W.: 274.4 lbs G.W.: 330.7 lbs  
 Gas consumption(m³/h):  
 NG: 3.156 / LPG:1.36

Quantity of Burners: 6  
 Quantity of Controls: 6  
 Power(BTU): 20,000X6

#### SBR-4829-N / SBR-4829-P

Size(W\*D\*H): 1219.2X738X334.5mm  
 Size(W\*D\*H): 48"X29.06"X13.17" N.W. :  
 159.5kg G.W. : 194kg  
 N.W.: 351.6 lbs G.W.: 427.7 lbs  
 Gas consumption(m³/h):  
 NG: 4.209 / LPG: 1.813

Quantity of Burners: 8  
 Quantity of Controls: 8  
 Power(BTU): 20,000X8

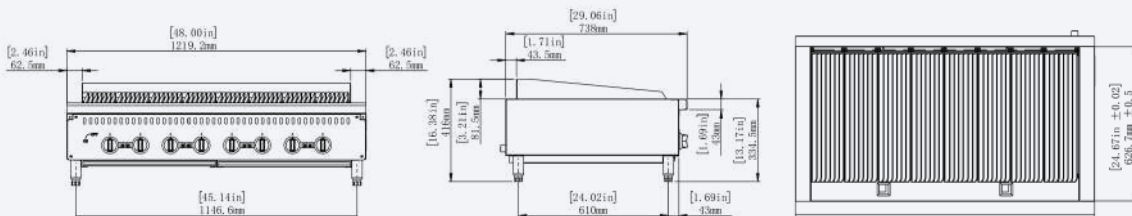

All above parameters for reference only, take practicality as standard.



# Standard Series



ENTREE LLC.

Tel: (704) 900 2068 E-mail: [solaris@entree.biz](mailto:solaris@entree.biz) Web: [www.entree.biz](http://www.entree.biz)



## Gas Countertop Griddle

### Features

- Key components have CSA / ETL certificate
- 4" adjustable stainless steel legs (removed for packaging to prevent concealed damage and lower shipping costs)
- Equipped with convertible appliance regulator (Maximum pressure ½ P.S.I.)
- Gas conversion kit shipped standard to convert to appropriate incoming gas
- 5/8" thick steel plate on 12", 18", 24", and 36" models for quick recovery
- 3/4" thick steel plate on 48", 60", and 72" models for even heating
- 3" side splash guards
- Grease container easily removed for cleaning
- Infinite valve control
- Standard duty countertop griddle

#### SGR-1226-N / SGR-1226-P

Size(W\*D\*H): 307X664.1X402.6mm  
 Size(W\*D\*H): 12.09"X26.15"X15.85"  
 N.W. : 34kg G.W. : 44.5kg  
 Gas consumption(m³/h):  
 NG: 0.789 / LPG: 0.34

Quantity of Burners: 1  
 Quantity of Controls: 1  
 Cooking Surface: 11.97"X18.98"  
 Plate Thickness: 0.63"  
 Power(BTU): 30,000X1

#### SGR-1826-N / SGR-1826-P

Size(W\*D\*H): 456X663X405mm  
 Size(W\*D\*H): 17.97"X26.03"X15.92"  
 N.W. : 44.5kg G.W. : 59kg  
 Gas consumption(m³/h):  
 NG: 0.789 / LPG: 0.34

Quantity of Burners: 1  
 Quantity of Controls: 1  
 Cooking Surface: 17.78"X18.98"  
 Plate Thickness: 0.63"  
 Power(BTU): 30,000X1

#### SGR-2426-N / SGR-2426-P

Size(W\*D\*H): 604X661.2X404.2mm  
 Size(W\*D\*H): 23.78"X26.03"X15.92"  
 N.W. : 57kg G.W. : 73kg  
 Gas consumption(m³/h):  
 NG: 1.578 / LPG: 0.68

Quantity of Burners: 2  
 Quantity of Controls: 2  
 Cooking Surface: 23.60"X18.98"  
 Plate Thickness: 0.63"  
 Power(BTU): 30,000X2

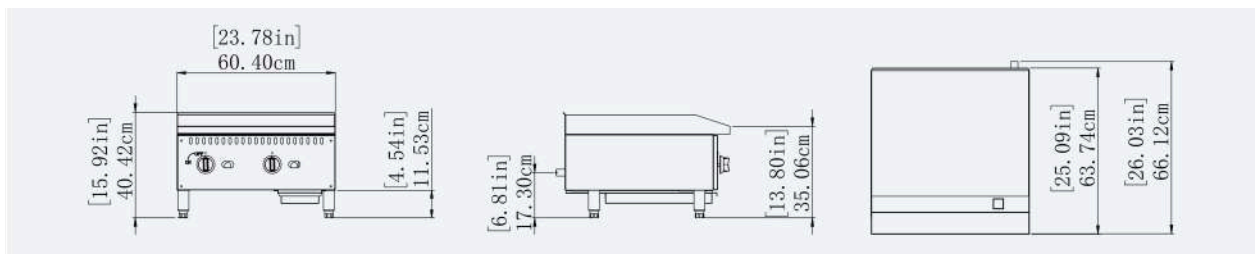

All above parameters for reference only, take practicality as standard.



## Gas Countertop Griddle

### Features

- Key components have CSA / ETL certificate
- 4" adjustable stainless steel legs (removed for packaging to prevent concealed damage and lower shipping costs)
- Equipped with convertible appliance regulator (Maximum pressure ½ P.S.I.)
- Gas conversion kit shipped standard to convert to appropriate incoming gas
- 5/8" thick steel plate on 12", 18", 24", and 36" models for quick recovery
- 3/4" thick steel plate on 48", 60", and 72" models for even heating
- 3" side splash guards
- Grease container easily removed for cleaning
- Infinite valve control
- Standard duty countertop griddle

#### SGR-3626-N / SGR-3626-P

Size(W\*D\*H): 904X663X405mm  
 Size(W\*D\*H): 36"X26.11"X15.92" N.W. :  
 75kg G.W. : 99kg  
 N.W.: 165.3 lbs G.W.: 218.3 lbs  
 Gas consumption(m³/h):  
 NG: 2.367 / LPG: 1.02

Quantity of Burners: 3 Quantity of  
 Controls: 3 Cooking Surface:  
 35.41"X18.98" Plate Thickness:  
 0.63" Power(BTU): 30,000X3

#### SGR-4826-N / SGR-4826-P

Size(W\*D\*H): 1204X661.7X405.4mm  
 Size(W\*D\*H): 47.4"X26.05"X15.96" N.W.  
 : 126.5kg G.W. : 155kg  
 N.W.: 278.9 lbs G.W.: 341.7 lbs  
 Gas consumption(m³/h):  
 NG: 3.156 / LPG: 1.36

Quantity of Burners: 4 Quantity of  
 Controls: 4 Cooking Surface:  
 47.22"X18.98" Plate Thickness:  
 0.75" Power(BTU): 30,000X4

#### SGR-6026-N / SGR-6026-P

Size(W\*D\*H): 1503X663.7X402.4mm  
 Size(W\*D\*H): 59.17"X26.13"X15.84" N.W.  
 : kg G.W. : kg Gas consumption(m³/h):  
 NG: / LPG:

Quantity of Burners: 5 Quantity of  
 Controls: 5 Cooking Surface:  
 59.04"X18.98" Plate Thickness:  
 0.75" Power(BTU): 30,000X5

#### SGR-7226-N / SGR-7226-P

Size(W\*D\*H): 1803X663.7X402.4mm  
 Size(W\*D\*H): 70.98"X26.13"X15.84" N.W.  
 : kg G.W. : kg Gas consumption(m³/h):  
 NG: / LPG:

Quantity of Burners: 6 Quantity of  
 Controls: 6 Cooking Surface:  
 70.85"X18.98" Plate Thickness:  
 0.75" Power(BTU): 30,000X6



All above parameters for reference only, take practicality as standard.



## Gas Countertop Charbroiler

### Features

- Key components have CSA / ETL certificate
- 4" adjustable stainless steel legs (removed for packaging to prevent concealed damage and lower shipping costs)
- Equipped with convertible appliance regulator (Maximum pressure ½ P.S.I.)
- Gas conversion kit shipped standard to convert to appropriate incoming gas
- Cast iron grill grates are reversible and height adjustable
- 3" side splash guards
- Full width crumb tray easily removed for cleaning
- Infinite valve control
- 3/4" NPT rear gas connection
- Standard duty charbroiler

#### SBR-1226-N / SBR-1226-P

Size(W\*D\*H): 308X661.7X402.9mm  
 Size(W\*D\*H): 12.13"X26.05"X15.86"  
 N.W. : 26kg G.W. : 37kg  
 N.W.: 57.3 lbs G.W.: 81.6 lbs  
 Gas consumption(m³/h):  
 NG: 0.789 / LPG: 0.34

Quantity of Burners: 1  
 Quantity of Controls: 1  
 Power(BTU): 30,000X1

#### SBR-1626-N / SBR-1626-P

Size(W\*D\*H): 404X663X405mm  
 Size(W\*D\*H): 15.91"X26.13"X15.95"  
 N.W. : 31kg G.W. : 44kg  
 N.W.: 68.3 lbs G.W.: 97.0 lbs  
 Gas consumption(m³/h):  
 NG: 0.789 / LPG: 0.34

Quantity of Burners: 1  
 Quantity of Controls: 1  
 Power(BTU): 30,000X1

#### SBR-2426-N / SBR-2426-P

Size(W\*D\*H): 604X663.6X404.6mm  
 Size(W\*D\*H): 23.78"X26.13"X15.93"  
 N.W. : 43.5kg G.W. : 59.5kg  
 N.W.: 95.9 lbs G.W.: 131.2 lbs  
 Gas consumption(m³/h):  
 NG: 1.578 / LPG: 0.68

Quantity of Burners: 2  
 Quantity of Controls: 2  
 Power(BTU): 30,000X2

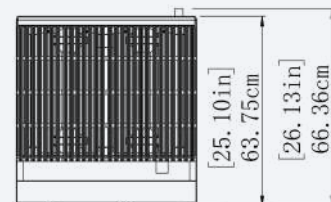
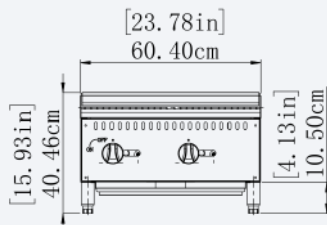

All above parameters for reference only, take practicality as standard.



## Gas Countertop Charbroiler

### Features

- Key components have CSA / ETL certificate
- 4" adjustable stainless steel legs (removed for packaging to prevent concealed damage and lower shipping costs)
- Equipped with convertible appliance regulator (Maximum pressure ½ P.S.I.)
- Gas conversion kit shipped standard to convert to appropriate incoming gas
- Cast iron grill grates are reversible and height adjustable
- 3" side splash guards
- Full width crumb tray easily removed for cleaning
- Infinite valve control
- 3/4" NPT rear gas connection
- Standard duty charbroiler

#### SBR-3626-N / SBR-3626-P

Size(W\*D\*H): 904X663X405mm  
 Size(W\*D\*H): 35.59"X26.13"X15.95"  
 N.W. : 65kg G.W. : 86kg  
 N.W.: 143.3 lbs G.W.: 189.6 lbs  
 Gas consumption(m³/h):  
 NG: 2.367 / LPG: 1.02

Quantity of Burners: 3  
 Quantity of Controls: 3  
 Power(BTU): 30,000X3

#### SBR-4826-N / SBR-4826-P

Size(W\*D\*H): 1204X665.5X405.1mm  
 Size(W\*D\*H): 47.4"X26.2"X15.95" N.W. :  
 90kg G.W. : 116kg  
 N.W.: 198.4 lbs G.W.: 255.7 lbs  
 Gas consumption(m³/h):  
 NG: 3.156 / LPG: 1.36

Quantity of Burners: 4  
 Quantity of Controls: 4  
 Power(BTU): 30,000X4

#### SBR-6026-N / SBR-6026-P

Size(W\*D\*H): 1507X663.2X403.58mm  
 Size(W\*D\*H): 59.33"X26.11"X15.89" N.W. :  
 102kg G.W. : 134kg  
 N.W.: 224.9 lbs G.W.: 295.5 lbs  
 Gas consumption(m³/h):  
 NG: / LPG:

Quantity of Burners: 5  
 Quantity of Controls: 15  
 Power(BTU): 30,000X5

#### SBR-7226-N / SBR-7226-P

Size(W\*D\*H): 1804X663.2X403.6mm  
 Size(W\*D\*H): 71.02"X26.11"X15.89" N.W. :  
 : kg G.W. : kg Gas consumption(m³/h):  
 NG: / LPG:

Quantity of Burners: 6  
 Quantity of Controls: 6  
 Power(BTU): 30,000X6



All above parameters for reference only, take practicality as standard.



# ELECTRIC FRYER



ENTREE LLC.

Tel: (704) 900 2068 E-mail: [solaris@entree.biz](mailto:solaris@entree.biz) Web: [www.entree.biz](http://www.entree.biz)



## Fryer

### Electric 1-Tank Fryer

Size(W\*D\*H): 285x430x305mm  
 Size(W\*D\*H): 11.22 × 16.93 × 12.01  
 Power: 2.5x2KW

N.W.: 2.85KG  
 N.W.: 6.28 lbs  
 Volts: 220-230V/50Hz  
 Capacity: 5.5L / 12.1 lbs

### Electric 1-Tank Fryer

Size(W\*D\*H) : 570x430x305mm  
 Size(W\*D\*H) :22.44 × 16.93 × 12.01  
 Power: 2.5x2KW

N.W.: 4.55KG  
 N.W.: 10.03 lbs  
 Volts: 220-230V/50Hz  
 Capacity: 11L / 24.3 lbs

### Electric 1-Tank Fryer

Size(W\*D\*H): 570x430x305mm  
 Size(W\*D\*H): 22.44 × 16.93 × 12.01  
 Power: 2.5x2KW

N.W.: 5.85KG  
 N.W.: 12.90 lbs  
 Volts: 220-230V/50Hz  
 Capacity: 11L / 24.3 lbs

### Electric 1-Tank Fryer

Size(W\*D\*H): 330×600×435mm  
 Size(W\*D\*H): 12.99 × 23.62 × 17.13  
 Power: 4.5+4.5KW

N.W.: 18KG  
 N.W.: 39.68 lbs  
 Volts: 220-240V/50Hz  
 Capacity: 12.5L / 28 lbs

### Electric 1-Tank Fryer

Size(W\*D\*H): 660×600×435mm  
 Size(W\*D\*H): 25.98 × 23.62 × 17.13  
 Power: 4.5+4.5KW

N.W.: 29KG  
 N.W.: 63.93 lbs  
 Volts: 220-240V/50Hz  
 Capacity: 25L / 28 lbs



All above parameters for reference only, take practicality as standard.



## Electric Fryer

### ECFS-4L-208/ECFS-4L-240

Size(W\*D\*H): 260×380×310mm

Size(W\*D\*H): 10.24 × 14.96 × 12.2"

Power: 2KW

Volts: 220-240V/50Hz

Capacity: 4L / 9 lbs

N.W.: 5KG

N.W.: 11.02 lbs

### ECFS-6L-208/ECFS-6L-240

Size(W\*D\*H): 310×410×285mm

Size(W\*D\*H): 12.20 × 16.14 × 11.22"

Power: 2.5KW

Volts : 220-240V/50Hz

Capacity: 6L / 13.23 lbs

N.W.: 5.5KG

N.W.: 12.13 lbs

### ECFS-8L-208/ECFS-8L-240

Size(W\*D\*H): 310×410×340mm

Size(W\*D\*H): 12.20 × 16.14 × 13.39"

Power: 3.25KW

Volts: 220-240V/50Hz

Capacity: 8L / 17.64 lbs

N.W.: 6KG

N.W.: 13.23 lbs

### ECFS-11L-208/ECFS-11L-240

Size(W\*D\*H): 320×440×340mm

Size(W\*D\*H): 12.60 × 17.32 × 13.39"

Power: 3.5KW

Volts: 220-240V/50Hz

Capacity: 11L / 17.64 lbs

N.W.: 7KG

N.W.: 15.43 lbs



All above parameters for reference only, take practicality as standard.



## Fryer

### ECFS-4L-2-208/ECFS-4L-2-240

Size(W\*D\*H): 480×380×310mm  
Size(W\*D\*H): 18.90 × 14.96 × 12.20"  
Power: 2KW+2KW

Volts: 220-240V/50Hz  
Capacity: 4L+4L / 17.64 lbs  
N.W.: 9.5KG  
N.W.: 20.94 lbs

### ECFS-6L-2-208/ECFS-6L-2-240

Size(W\*D\*H): 550×410×285mm  
Size(W\*D\*H): 21.65 × 16.14 × 11.22"  
Power: 2.5KW+2.5KW

Volts: 220-240V/50Hz  
Capacity: 6L+6L / 17.64 lbs  
N.W.: 12KG  
N.W.: 26.46 lbs

### ECFS-8L-2-208/ECFS-8L-2-240

Size(W\*D\*H): 550×410×340mm  
Size(W\*D\*H): 21.65 × 16.14 × 13.39"  
Power: 3.25KW+3.25KW

Volts: 220-240V/50Hz  
Capacity: 8L+8L / 35.27 lbs  
N.W.: 14KG  
N.W.: 30.86 lbs

### ECFS-11L-2-208/ECFS-11L-2-240

Size(W\*D\*H): 670×440×340mm  
Size(W\*D\*H): 26.38 × 17.32 × 13.39"  
Power: 3.5KW+3.5KW

Volts: 220-240V/50Hz  
Capacity: 11L+11L / 48.50 lbs  
N.W.: 15KG  
N.W.: 33.07 lbs



All above parameters for reference only, take practicality as standard.



# Electric Convection Oven:

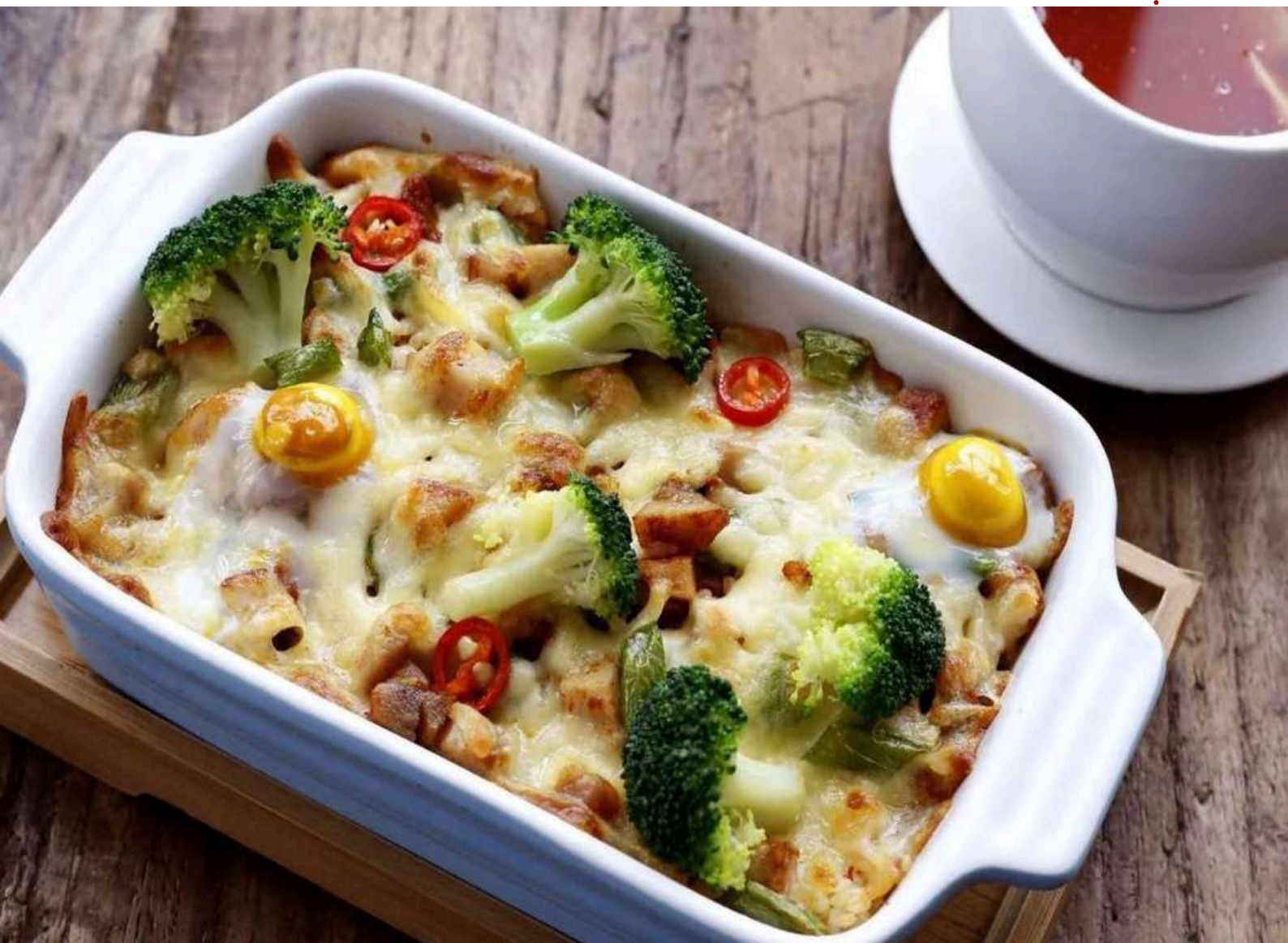



## Electric Convection Oven(SS chamber)

### ECCSO1A-208/ECCSO1A-240

Size(W\*D\*H): 596x532x570mm  
Size(W\*D\*H): 23.46 × 20.94 × 22.44  
Chamber size: 460×373×358mm  
Chamber size: 18.11 × 14.69 × 14.09  
Tray size: 435×315mm  
Tray size: 17.13 × 12.40

Temperature range: 50-300  
Volts: 220-240V/50Hz  
Power: 2.67KW

### ECCOS1E-208/ECCOS1E-240

Size(W\*D\*H): 596x532x570mm  
Size(W\*D\*H): 23.46 × 20.94 × 22.44  
Chamber size: 460×373×358mm  
Chamber size: 18.11 × 14.69 × 14.09  
Tray size: 435×315mm  
Tray size: 17.13 × 12.40

Temperature range: 50-300  
Volts: 220-240V/50Hz  
Power: 2.67KW

### ECCOS1W-208/ECCOS1W-240

Size(W\*D\*H): 596x532x570mm  
Size(W\*D\*H): 596x532x570mm  
Chamber size: 460×373×358mm  
Chamber size: 460×373×358mm  
Tray size: 435×315mm  
Tray size: 435×315mm

Temperature range: 50-300°C  
Volts: 220-240V/50Hz  
Power: 2.67KW+2KW



All above parameters for reference only, take practicality as standard.



### Electric Convection Oven

### Features

- ETL safety and sanitation certified
- Top and front stainless steel construction with aluminum back and powder coated silver sides
- Long triangular legs for strength and durability with adjustable casters standard (-C) or optional stationary legs (-L)
- Double pane glass doors with interlock switch that automatically turns the fan and elements off when open
- Heavy duty F.I.R. convection fan motor, 1/2 HP, two speed
- Accurate solid state oven thermostat with temperature range from 150°F to 500°F (66°C–260°C)
- 60 minute continuous ring timer with manual shut off
- Temperature ready indicator light
- Five heavy duty chrome plated oven racks with 10 position rack guides and 1.5" spacing
- Seamless enamel interior and corners for easy cleaning
- 1ph and 3ph convertible in the field
- Stacking kit available for double stacking (interconnect wiring not included) — order stacking kit #SKES-C
- For casters (standard) use "-C", for legs without casters use "-L"

### ECO1S-208-3-L

Size(W\*D\*H) 968.7 × 1031.2 × 1374.1 mm  
 Size(W\*D\*H): 38.1"X40.6"X54.1  
 Chamber size: 736.6 × 546.1 × 508 mm  
 Chamber size: 29"X21.5"X20"

Volts: 208V/60HZ/1PH; 208V/60HZ/3PH  
 Power: 9KW

### ECO2S-208-3-L

Size(W\*D\*H): 968.7 × 1031.2 × 1374.1 mm  
 Size(W\*D\*H): 38.1"X40.6"X54.1"  
 Chamber size: 736.6 × 546.1 × 508 mm  
 Chamber size: 29"X21.5"X20"

Volts: 240V/60HZ/1PH; 240V/60HZ/3PH  
 Power: 11KW

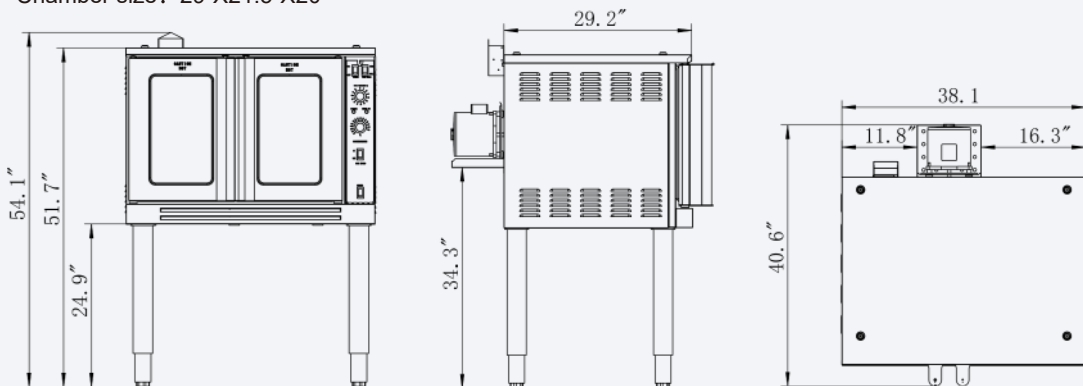

All above parameters for reference only, take practicality as standard.



## Double-Layer Electric Convection Oven

### Features

- Top and front with stainless steel construction.
  - Double pane thermal glass windows on doors.
  - Steel legs with adjustable bullet feet.
  - Doors have an interlock switch that automatically turns the fan and heater off when open.
  - Oven interior measures 29" x 21.5" x 20".
  - 1/2 HP two speed fan motor.
  - Cooking chamber is lined with porcelain enamel.
  - 10 position guide rack with 1.5" spacing in between.
  - 5 heavy duty adjustable chrome plated racks.
  - Seamless interior and corners for easy cleaning.
  - Accurate solid state oven thermostat with a range from 150°F - 500°F or 66°C-260°C.
  - 60 minute continuous ring timer - manual shut off.
  - Temperature ready indicator light.
- For casters (standard) use "-C", for legs without casters use "-L"

### ECO1S-208-3-C

Size(W\*D\*H):968.7 × 1031.2 × 1574.8 mm  
 Size(W\*D\*H): 38.1"X40.6"X62"  
 Chamber size: 736.6 × 546.1 × 508 mm  
 Chamber size: 29"X21.5"X20"

Volts: 208V/60HZ/1PH; 208V/60HZ/3PH  
 Power: 9KW\*2

### ECO2S-208-3-C

Size(W\*D\*H): 968.7 × 1031.2 × 1574.8 mm  
 Size(W\*D\*H):38.1"X40.6"X62"  
 Chamber size: 736.6 × 546.1 × 508 mm  
 Chamber size: 29"X21.5"X20"

Volts: 240V/60HZ/1PH; 240V/60HZ/3PH  
 Power: 11KW\*2

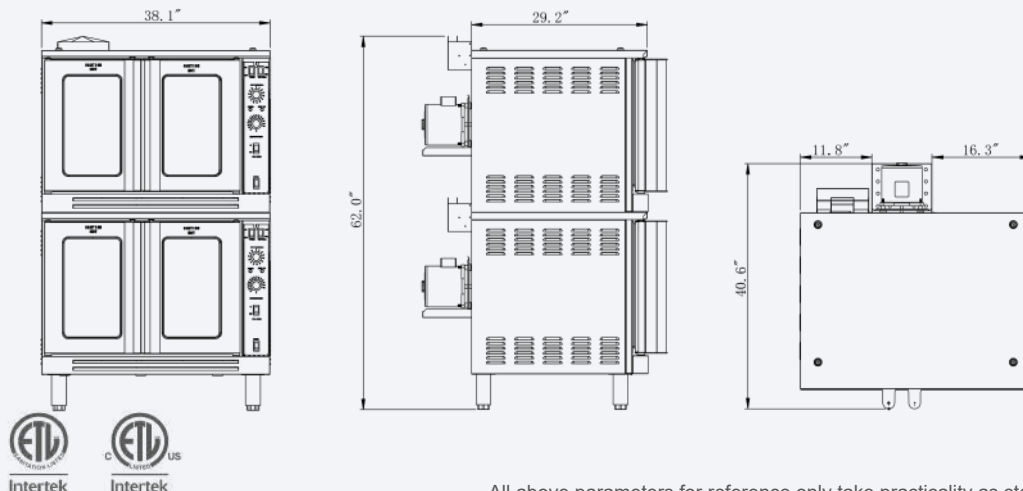

All above parameters for reference only,take practicality as standard.

ENTREE LLC.

Tel: (704) 900 2068 E-mail: solaris@entree.biz Web: www.entree.biz



# GRIDDLE



ENTREE LLC.

Tel: (704) 900 2068 E-mail: [solaris@entree.biz](mailto:solaris@entree.biz) Web: [www.entree.biz](http://www.entree.biz)



## Electric Griddle

### EGS-2114-208/EGS-2114-240

Size(W\*D\*H): 550x460x235mm  
Size(W\*D\*H): 21.65 × 18.11 × 9.25"  
Griddle size: 548x350x10mm  
Griddle size: 21.57 × 13.78 × 0.39"

Power: 3KW  
N.W.: 12.3KG  
N.W.: 27.12 lbs  
Volts: 220-230V/50Hz

### EGS-2816-208/EGS-2816-240

Size(W\*D\*H): 730x480x220mm  
Size(W\*D\*H): 28.74 × 18.90 × 8.66"  
Griddle size: 728x400x10mm  
Griddle size: 28.66 × 15.75 × 0.39"

Power: 4.4KW  
N.W.: 30KG  
N.W.: 66.14 lbs  
Volts: 220-230V/50Hz

All above parameters for reference only,take practicality as standard.



## Electric Griddle

### EGSG-2816-208/EGSG-2816-240

Size(W\*D\*H): 730x480x220mm  
Size(W\*D\*H): 28.74 × 18.90 × 8.66"  
Griddle size: 728x400x10mm  
Griddle size: 28.66 × 15.75 × 0.39"

Power: 4.4KW  
N.W.: 30KG  
N.W.: 66.14 lbs  
Volts: 220-230V/50Hz

All above parameters for reference only,take practicality as standard.



## Electric Single Panini grill

### EPGS12G

Size(W\*D\*H): 290x395x210mm  
 Size(W\*D\*H): 11.42 × 15.55 × 8.27"  
 Griddle size: 214x214mm  
 Griddle size: 8.43 × 8.43

Power: 1.8KW  
 N.W.: 14KG  
 N.W.: 30.86 lbs  
 Volts: 220-240V/50Hz

### EPGS16G

Size(W\*D\*H): 410x395x210mm  
 Size(W\*D\*H): 16.14 × 15.55 × 8.27"  
 Griddle size: 340x220mm  
 Griddle size: 13.39 × 8.66

Power: 2.2KW  
 N.W.: 18KG  
 N.W.: 39.68 lbs  
 Volts: 220-240V/50Hz

All above parameters for reference only,take practicality as standard.



## Electric Griddle

### Electric Double Panini Grill

Model: HEG-813  
 Dimensions 570×395×210mm  
 Griddle size: 214x214mm  
 475x230mm (下)

Power: 3.6KW  
 N.W.: 45KG  
 Volts: 220-240V/50Hz

### Electric Double Panini Grill

Model: HEG-813E  
 Dimensions: 810×395×210mm  
 Griddle size: 340x220mm  
 759x285mm (下)

Power: 4.4KW  
 Volts: 220-240V/50Hz

All above parameters for reference only,take practicality as standard.



## Electric Griddle (Flat)

### EGS-1013-208/EGS-1013-240

Size(W\*D\*H): 260×420×270 mm  
Size(W\*D\*H): 10.24 × 16.54 × 10.63  
Griddle size: 256x328x12mm  
Griddle size: 10.08 × 12.91 × 0.47

Power: 1.5KW  
N.W.: 16.5KG  
N.W.: 36.39 lbs  
Volts: 220-240V/50Hz

### EGS-1615-208/EGS-1615-240

Size(W\*D\*H): 400×500×270mm  
Size(W\*D\*H): 15.75 × 19.69 × 10.63  
Griddle size: 400x396x12mm  
Griddle size: 15.75 × 15.59 × 0.47

Power: 3KW  
N.W.: 26.5KG  
N.W.: 58.42 lbs  
Volts: 220-240V/50Hz

### EGS-2214-208/EGS-2214-240

Size(W\*D\*H): 550×450×270mm  
Size(W\*D\*H): 21.65 × 17.72 × 10.63  
Griddle size: 546x350x12mm  
Griddle size: 21.50 × 13.78 × 0.47

Power: 3KW  
N.W.: 32KG  
N.W.: 70.55 lbs  
Volts: 220-240V/50Hz

### EGS-2416-208/EGS-2416-240

Size(W\*D\*H): 610×500×270mm  
Size(W\*D\*H): 24.02 × 19.69 × 10.63  
Griddle size: 606x400x12mm  
Griddle size: 23.86 × 15.75 × 0.47

Power: 6KW  
N.W.: 40KG  
N.W.: 88.18 lbs  
Volts: 380V/50Hz

### EGS-3016-208/EGS-3016-240

Size(W\*D\*H): 760×500×270mm  
Size(W\*D\*H): 29.92 × 19.69 × 10.63  
Griddle size: 756x400x12mm  
Griddle size: 29.76 × 15.75 × 0.47

Power: 9KW  
NW: 48KG  
NW: 105.82 lbs  
Volts: 380V/50Hz

All above parameters for reference only, take practicality as standard.



# FOOD WARMER



ENTREE LLC.

Tel: (704) 900 2068 E-mail: [solaris@entree.biz](mailto:solaris@entree.biz) Web: [www.entree.biz](http://www.entree.biz)



## Electric Bain Marie

### ECBMS2-208/ECBMS2-240

Model: HEB-2V

Size(W\*D\*H): 590×385×230mm

Size(W\*D\*H): 23.2"×15.2"× 9.1"

Power: 1.5KW

N.W.: 9.5KG

N.W.: 20.94 lbs

Volts: 220-240V/50Hz

Capacity: 2x1/2 G/N Pan

### ECBMS3-208/ECBMS3-240

Size(W\*D\*H): 605×385×280mm

Size(W\*D\*H): 23.82 × 15.16 × 11.02

Power: 1.5KW

N.W.: 12KG

N.W.: 26.46 lbs

Volts: 220-240V/50Hz

Capacity: 3x1/3 G/N Pan

### ECBMS4-208/ECBMS4-240

Size(W\*D\*H): 695×610×280mm

Size(W\*D\*H): 27.36 × 24.02 × 11.02

Power: 1.5KW

N.W.: 18KG

N.W.: 39.68 lbs

Volts: 220-240V/50Hz

Capacity: 4 GN1/2

### ECBMS4V-208/ECBMS4V-240

Size(W\*D\*H): 700×590×230mm

Size(W\*D\*H): 727.56 × 23.23 × 9.06

Power: 1.5KW

N.W.: 16KG

N.W.: 35.27 lbs

Volts: 220-240V/50Hz

Capacity: 4 GN1/2

### ECBMS6V-208/ECBMS6V-240

Size(W\*D\*H): 695×635×280mm

Size(W\*D\*H): 27.36 × 25.00 × 11.02

Power: 1.5KW

N.W.: 19KG

N.W.: 41.89 lbs

Volts: 220-240V/50Hz

Capacity: 6 GN1/3

All above parameters for reference only, take practicality as standard.



## Bain Marie

### ECFS-165-208/ECFS-165-240

Size(W\*D\*H): 355×615×255mm  
Size(W\*D\*H): 13.98 × 24.21 × 10.04"  
Power: 1.2KW

N.W.: 10.5KG  
N.W.: 22.05 lbs  
Volts: 220-240V/50Hz  
Capacity: 1x1/1 G/N Pan

All above parameters for reference only, take practicality as standard.



## Bain

### ECFS-165-208/ECFS-165-240

Size(W\*D\*H): 355×555×295mm  
Size(W\*D\*H): 13.98 × 21.85 × 11.61"  
Power: 1.2KW

N.W.: 12KG  
N.W.: 26.46 lbs  
Volts: 220-240V/50Hz  
Capacity: 1x1/1 G/N Pan

All above parameters for reference only, take practicality as standard.



## Salamander

### ESS936-208/ESS936-240

Size(W\*D\*H): 570×340×260mm  
Size(W\*D\*H): 22.44 × 13.39 × 10.24  
Power: 2KW

N.W.: 17KG  
N.W.: 37.48 lbs  
Volts: 220-240V/50Hz

### ESS937-208/ESS937-240

Size(W\*D\*H): 800×450×470mm  
Size(W\*D\*H): 31.50 × 17.72 × 18.50  
Power: 4KW

N.W.: 28KG  
N.W.: 61.73 lbs  
Volts: 220-240V/50Hz

### ESS938-208/ESS938-240

Size(W\*D\*H): 580×390×390mm  
Size(W\*D\*H): 22.83 × 15.35 × 15.35  
Power: 2.2KW

N.W.: 18KG  
N.W.: 39.68  
Volts: 220-240V/50Hz

All above parameters for reference only,take practicality as standard.

THANK YOU FOR EXPLORING



PRECISION MEETS PERFORMANCE

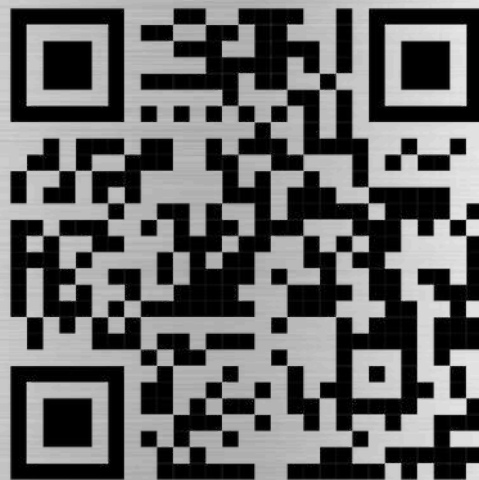

[www.entree.biz](http://www.entree.biz)

[solaris@entree.biz](mailto:solaris@entree.biz)