



Item # _____

Electric Standard Depth Convection



Model: ECOR

- EECOR-1-208-1 Electric convection oven
- EECOR-1-208-3 Electric convection oven
- EECOR-1-240-1 Electric convection oven
- EECOR-1-240-3 Electric convection oven

STANDARD FEATURES

- Two speeds convection motor
- Solid state thermostat control
- Full sheet size cavity, total 13 rack positions
- Temperature adjustable from 150 to 500°F
- Five (5) wire racks shipped as standard
- Independent double layer glass doors design
- Interior lamp
- Porcelain cavity for easy cleaning
- Stackable design
- Swivel casters with brake

Plan View

EECOR-1

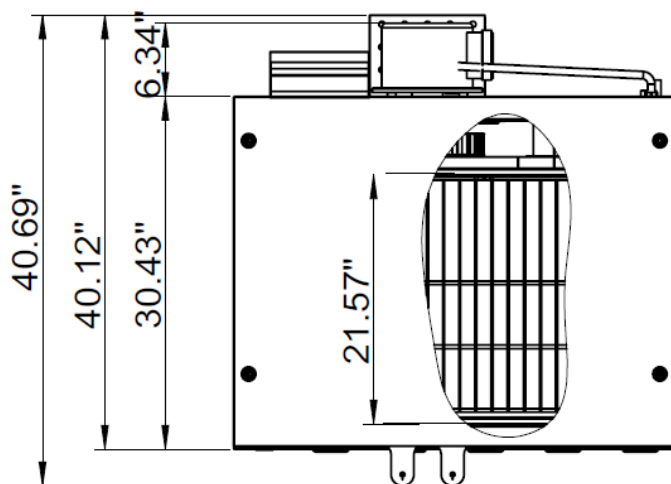
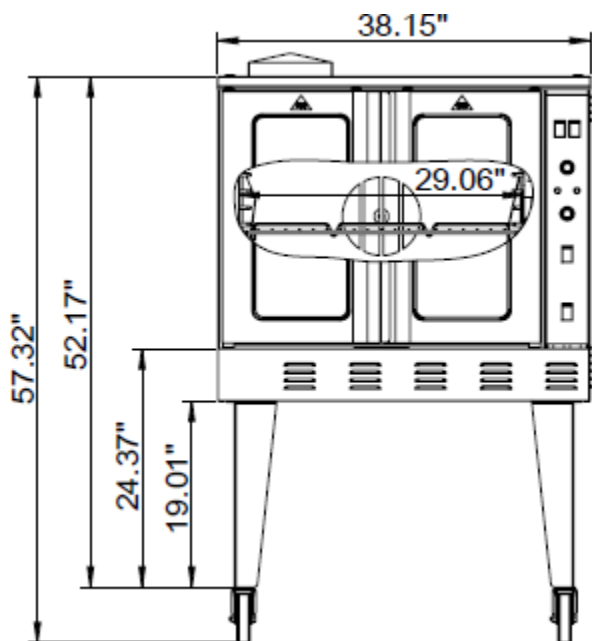



Item # _____

Electric Standard Depth Convection

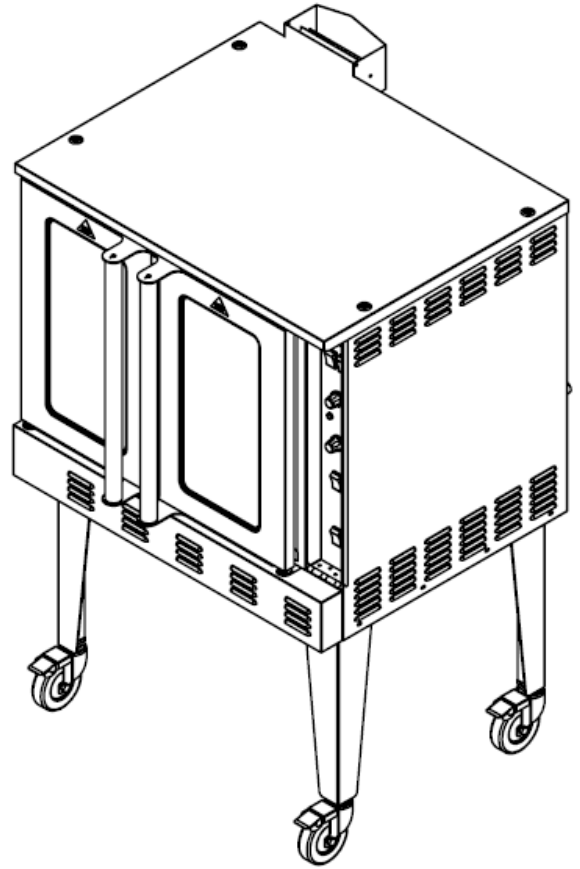
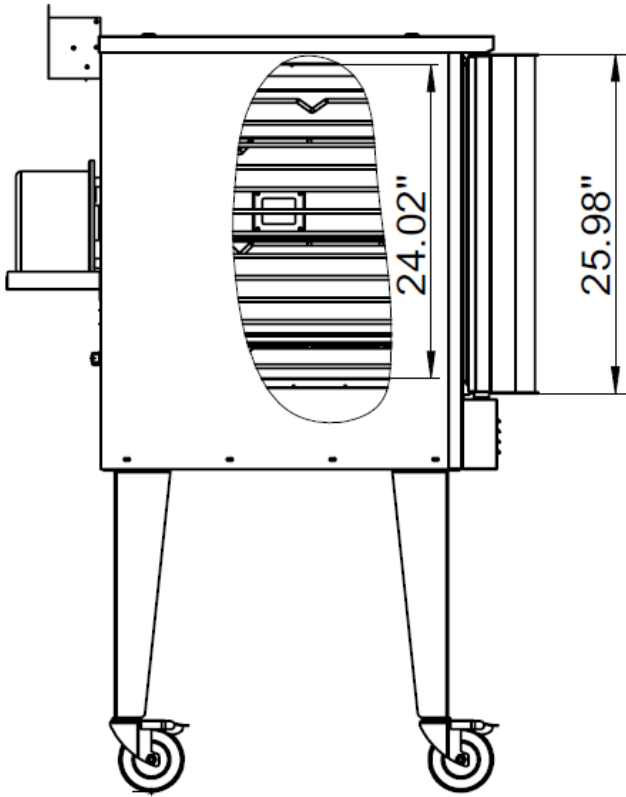

Model	Power	Volts/Hz	Phase	Cavity Size (Inch)	Shelf	Temperature
EECOR-1-208-1	9kW	208VAC-60Hz	1	29" x 22.25" x 24"	5	150°F to 500°F
EECOR-1-208-3	9kW	208VAC-60Hz	3	29" x 22.25" x 24"	5	150°F to 500°F
EECOR-1-240-1	10kW	240VAC-60Hz	1	29" x 22.25" x 24"	5	150°F to 500°F
EECOR-1-240-3	10kW	240VAC-60Hz	3	29" x 22.25" x 24"	5	150°F to 500°F

ENTRÉE L.L.C.
 Customer Service: (704) 900-2068
 Email: greatfood@entree.biz
 Website: www.entree.biz

Form EECOR Rev 20260210



C US SANITATION