

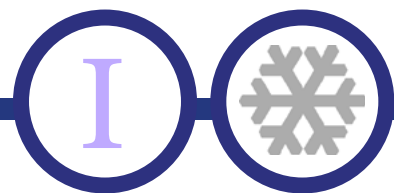

Refrigeration "X"



CUBE ICE MACHINE

ECIM350X



ECIM160X



Models	
Full Cube	Half Cube
ECIM160X	ECIM160X-5
ECIM210X	ECIM210X-5
ECIM280X	ECIM280X-5
ECIM350X	ECIM350X-5
ECIM420X	ECIM420X-5
ECIM530X	ECIM530X-5

Features

- Full & Half Size Cube Ice
- Air cooled condenser
- Durable stainless-steel exterior
- Left and Right side-in, rear-out airflow
- Bright LED light illuminate the ice bin
- Removable air filter allows for quick cleaning
- Digital controller allows user to quickly identify issues
- Ambient Temperature Range 41°F to 100°F
- Water Temperature Range 41°F to 90°F
- Water Pressure 18 to 80 P.S.I.
- Adjustable legs
- Warranty: 3 Years Parts & Labor, 3 Year Additional on Compressor

ECIM530X-5



*Not suitable for installation in a non-commercial or residential applications.

ECIM160X, ECIM160X-5, ECIM210X, ECIM210X-5, ECIM280X, AND ECIM280X-5

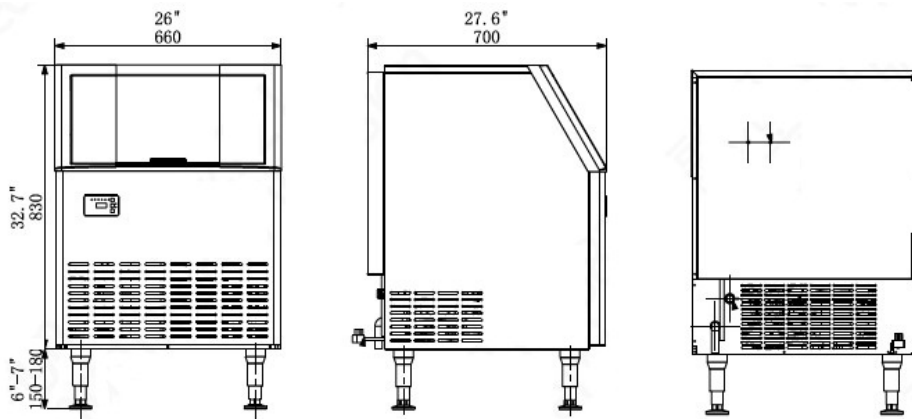

REFRIGERATION



DETAILS AND DIMENSIONS

Models:
 ECIM350X
 ECIM350X-5
 ECIM420X
 ECIM420X-5

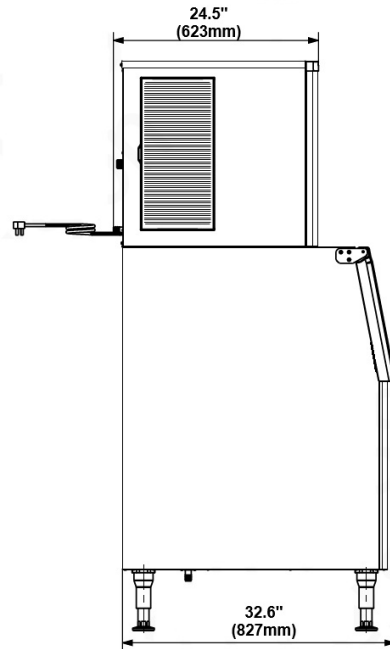
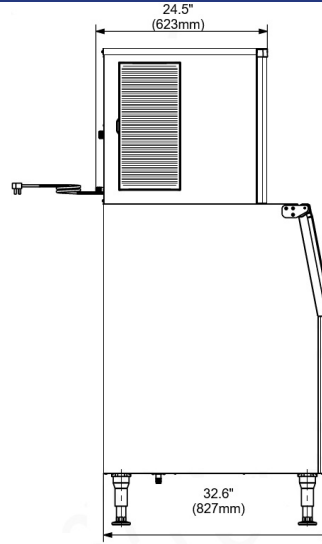
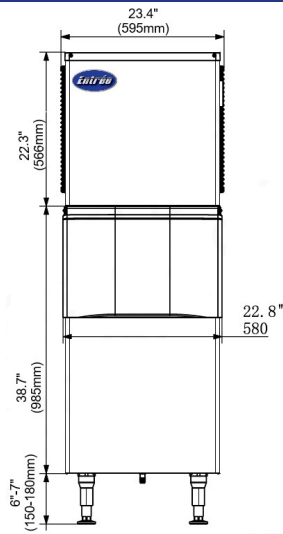
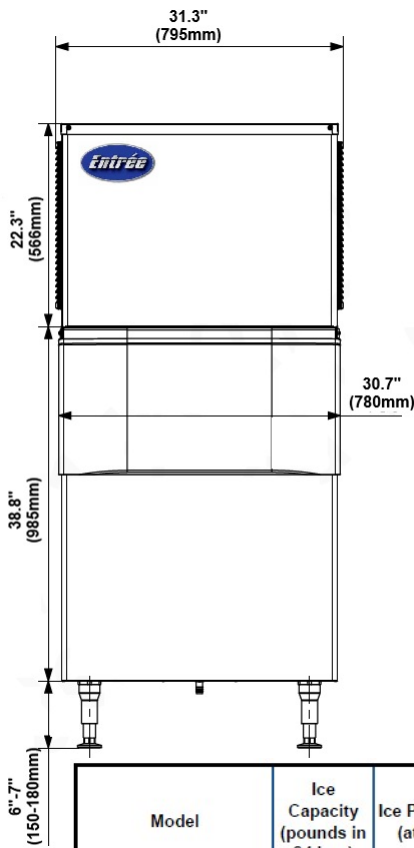

Model:
 ECIM530X
 ECIM530X-5

Model	Ice Capacity (pounds in 24 hrs.)	Ice Production/Day (at/wt:70/50°F)	Ice Storage	Water Inlet Size	Half Cube Size (inches)			Cube Weight oz./g	Full Cube Size (inches)			Cube Weight oz./g
					Width	Depth	Height		Width	Depth	Height	
ECIM160X/ECIM160X-5	160	157 lbs.	80 lbs.	3/4"	0.87"	0.51"	0.87"	.2/6	0.87"	0.87"	0.87"	.35/10
ECIM210X/ECIM210X-5	210	207 lbs.	80 lbs.	3/4"	0.87"	0.51"	0.87"	.2/6	0.87"	0.87"	0.87"	.35/10
ECIM280X/ECIM280X-5	280	280 lbs.	80 lbs.	3/4"	0.87"	0.51"	0.87"	.2/6	0.87"	0.87"	0.87"	.35/10
ECIM350X/ECIM350X-5	350	351 lbs.	275 lbs.	3/4"	1.14"	0.55"	0.87"	.28/8	1.14"	0.87"	0.87"	.46/13
ECIM420X/ECIM420X-5	420	410 lbs.	275 lbs.	3/4"	1.14"	0.55"	0.87"	.28/8	1.14"	0.87"	0.87"	.46/13
ECIM530X/ECIM530X-5	530	529 lbs.	375 lbs.	3/4"	1.14"	0.55"	0.87"	.28/8	1.14"	0.87"	0.87"	.46/13

Model	Cooling Exterior Dimension (inches)			Cooling Exterior Dimension (inches)			NEMA Style Plug	Voltage
	Width	Depth	Height	Width	Depth	Height		
ECIM160X/ECIM160X-5	26.1"	27.6"	28.2"				5-15P	115VAC/60Hz
ECIM210X/ECIM210X-5	26.1"	27.6"	28.2"				5-15P	115VAC/60Hz
ECIM280X/ECIM280X-5	26.1"	27.6"	28.2"				5-15P	115VAC/60Hz
ECIM350X/ECIM350X-5	23.4"	24.5"	22.3"	22.8"	32.6"	44.7"	5-15P	115VAC/60Hz
ECIM420X/ECIM420X-5	23.4"	24.5"	22.3"	22.8"	32.6"	44.7"	5-15P	115VAC/60Hz
ECIM530X/ECIM530X-5	31.3"	24.5"	22.3"	30.7"	32.6"	11.7"	5-15P	115VAC/60Hz

