



COMMERCIAL MODULAR ICE CUBE MACHINE

Service, Installation and Care Manual



Models:

**ECIM350X – Full Cube
ECIM350X-5 Half Cube
ECIM420X – Full Cube
ECIM420X-5 Half Cube
ECIM530X – Full Cube
ECIM530X-5 Half Cube**

Please read this manual completely before attempting to install or operate this equipment.
Notify carrier of damage! Inspect all components immediately.





Table of Contents

COMMERCIAL REFRIGERATION SAFETY..... 3

 General Safety Instructions 3

 Safety Precautions..... 4

 Refrigeration Safety Standard 5

 Additional Safety Warnings 5

SERIAL NUMBER INFORMATION 5

RECEIVING AND INSPECTING THE EQUIPMENT 5

INSTALLATION 6

 Location 6

 Leveling 6

 Stabilizing 6

 Service & Maintenance Safety 6

 Installation Instructions..... 7

 1. Construction 7

 2. Accessories 7

 3. Unpacking..... 8

 Water Filters 8

LOCATION REQUIREMENTS 9

 Electrical Supply 9

 Water Supply 9

 Environmental Conditions 9

 Clearance Requirements 9

 Floor Support 9

 Electrical Safety 9

 Drainage..... 9

 Installation Steps 9

OPERATING INSTRUCTIONS..... 11

MAINTENANCE 14

 Monthly Manual Cleaning & Sanitizing 16

 Disinfection Instructions 18

CALLING FOR SERVICE 23

 Troubleshooting 24





⚠ IMPORTANT INFORMATION – READ BEFORE USE

Please read these instructions carefully before installing or operating this equipment. Save these instructions for future reference!

COMMERCIAL REFRIGERATION SAFETY

Your safety and the safety of others are very important.

This manual and the appliance contain many important safety messages. Always read and follow all safety instructions. Product instructions are also available on our company’s official website.

Safety Alert Symbol



This Safety Alert Symbol alerts you to potential hazards that can cause injury or death.

All safety messages will follow the Safety Alert Symbol and one of the following signal words:

	Danger means that failure to heed this safety statement may result in severe personal injury or death.
	Warning means that failure to heed this safety statement may result in extensive product damage, serious personal injury, or death.
	Caution means that failure to heed this safety statement may result in minor or moderate personal injury, or property or equipment damage.
	Water Connection Symbol - Indicates Connection to potable water supply

All safety messages will:

- Identify the potential hazard
- Explain how to reduce the risk of injury
- Describe the consequences of not following the instructions

General Safety Instructions

If the supply cord is damaged, it must be replaced by the manufacturer, its service agent, or similarly qualified personnel to avoid a hazard.

This appliance is not intended for use by persons (including children) with reduced physical, sensory, or mental capabilities, or by persons lacking experience or knowledge unless they have been given supervision or instruction concerning the use of the appliance by a person responsible for their safety.

Keep the appliance and its power cord out of reach of children under 8 years of age.

Do not store explosive substances such as aerosol cans with flammable propellants inside this appliance.

This appliance uses flammable insulation blowing gas (C5H10).

Disposal of this appliance must be carried out in accordance with local regulations.



Safety Precautions

CAUTION

1. Leave sufficient space between the cabinet, walls, and ceiling to allow proper ventilation. The rear of the cabinet must not be completely enclosed. Provide adequate ventilation to the outside.
Minimum clearance from wall: eight inches (8") (20 cm).
2. Remove all packaging materials from the bottom of the unit before operation to allow proper heat dissipation and reduce fire risk.
3. Do not store flammable or volatile chemicals in or near the appliance.
4. The appliance must be connected to a dedicated single-phase electrical outlet with proper grounding.
 - The outlet must be reliably grounded.
 - Do not connect the grounding wire to water pipes or gas pipes.
5. Avoid strong impacts or excessive vibration during transportation.
The cabinet tilt angle must not exceed 45°.
6. If the unit experiences operational problems, refer to the Troubleshooting Section. Do not attempt to repair the unit yourself. Service must be performed by a qualified technician.

⚠ WARNING ⚠ – Flammable Refrigerant

7. Risk of fire or explosion. Flammable refrigerant used.
Consult the repair manual or owner's guide before attempting to service this product. All safety precautions must be followed.
8. Risk of fire or explosion.
Dispose of the appliance in accordance with federal and local regulations.
9. Risk of fire or explosion due to puncture of refrigerant tubing.
Follow handling instructions carefully.
10. Keep all ventilation openings in the appliance enclosure or built-in structure clear of obstruction.
11. Servicing must be performed by supplier-authorized service personnel to minimize the risk of ignition due to incorrect parts or improper service.

⚠ DANGER ⚠ – Flammable Refrigerant

1. Risk of fire or explosion. Flammable refrigerant used.
Do not use mechanical devices or other means to accelerate the defrosting process unless recommended by the manufacturer. Do not puncture refrigerant tubing.
2. Risk of fire or explosion. Flammable refrigerant used.
Repairs must only be performed by trained service personnel.

Refrigeration Safety Standard

This appliance uses flammable refrigerant and must be installed in accordance with:

ANSI/ASHRAE 15 – Safety Standard for Refrigeration Systems

CLIMATE CLASSIFICATION

This appliance is rated Climate Class 4, defined as follows:

Climate Class	Dry Bulb Temp	Relative Humidity	Dew Point	Water Vapor Mass
4	86°F	44%	68°F	6.71 g/lb.

Additional Safety Warnings

Components must only be replaced with identical factory (OEM), replacement parts to minimize ignition risks.

- If the power supply cord is damaged, it must be replaced by the manufacturer, its service agent, or similarly qualified personnel.
- Hose sets are not supplied with this appliance. It highly recommended that new hose sets be used.



A3 Refrigerant Safety Warning

Do not use any means to accelerate the defrosting process or clean the appliance other than those recommended by the manufacturer.

The appliance must be stored in a room without continuously operating ignition sources, such as:

- Open flames
- Gas appliances
- Electric heaters

Do not pierce or burn refrigerant components.

SERIAL NUMBER INFORMATION

The serial number of all commercial ice cube machines is located outside of the unit on the right hand near the top of ice machine (not the bin portion). Always have the serial number and model number of your unit available when calling for parts or service.

RECEIVING AND INSPECTING THE EQUIPMENT

Although most equipment is shipped in protective crating, care should be taken when unloaded to prevent damage during transport into the building.

1. Visually inspect the exterior packaging, skid, or container. Any damage must be noted and reported to the delivery carrier immediately. Claims must typically be filed within 10 days.
2. If damage is present, open and inspect the contents with the carrier present.
3. If the exterior packaging appears undamaged but concealed damage is discovered after opening, notify the carrier immediately. Notification should be provided both verbally and in writing.
4. Request an inspection by the shipping company for any damaged equipment. This should be done within 10 days of receiving the shipment.
5. Inspect the compressor compartment and refrigeration components. Verify that refrigerant lines are secure and the base is intact.
6. Freight carriers can provide the necessary damage claim forms upon request.
7. Retain all packaging materials until the inspection has been completed or waived.



INSTALLATION

Location

Units described in this manual are intended for indoor use only.

Ensure the installation location has a floor capable of supporting the combined weight of the unit and its contents. A fully loaded unit may weigh up to 1,500 lbs. (680 kg).

Reinforce the floor if necessary.

Proper air circulation must be maintained inside and around the unit to ensure efficient refrigeration performance.

Leveling

A level ice machine improves both appearance, performance, and added safety.

Use a level to ensure the unit is level from front to back and side to side.

Units supplied with legs include adjustable bullet feet to allow proper leveling adjustments.

Stabilizing

If the unit has been laid on its side or back during transportation or installation, allow at least 24 hours before start-up to allow compressor oil to return to the compressor.

Failure to follow this procedure may result in compressor damage.

Damage caused by improper installation procedures may result in the loss of the manufacturer's warranty.

Service & Maintenance Safety

The unit must be turned OFF and disconnected from the power source before performing:

- Service
- Maintenance
- Cleaning of the refrigerated compartment





Installation Instructions

1. Construction (Model shown is EICM530X)

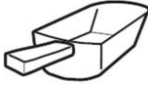
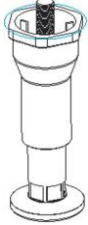
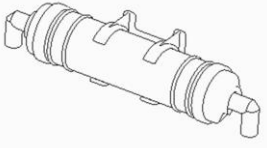

2. Accessories:

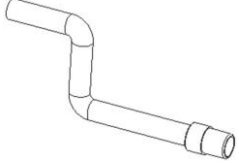
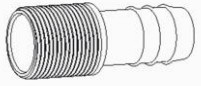
			
Instruction Manual	Scoop	Leg	Filter Component
			
Connector	Inlet Pipe	Drain-Pipe	Drain-pipe Connector



3. Unpacking

This appliance is intended for indoor commercial use only.

This product is not intended for outdoor use.

- ⚠ This appliance should not be used by children or by persons with reduced physical, sensory, or mental capabilities, or lack of experience and knowledge unless they are supervised or instructed by a responsible person.
- Installation, repair, and maintenance of this ice machine must be performed by qualified service personnel only. Improper installation or servicing may result in electric shock, fire, or personal injury.
- After delivery, keep the machine upright for at least 24 hours before starting the unit. This allows the refrigerant and compressor oil to stabilize. Failure to do so may cause compressor damage.
- During handling and transportation, keep the cabinet upright and do not tilt more than 45°. Do not invert the machine or lay it horizontally.
- Do not install this ice machine in wet areas or locations exposed to water splashing.
- The grounding connection for this ice machine must not be connected to gas pipes, water pipes, telephone lines, or lightning rods.
- This appliance contains moving mechanical components. Do not insert objects into the ventilation or exhaust openings, as this may cause equipment damage or personal injury.
- Do not store flammable or volatile substances in or near the ice machine.
- Do not store food, beverages, or miscellaneous items in the ice storage bin. The bin is intended for ice storage only. Always keep the ice scoop clean.
- The ice machine must be installed on a floor capable of supporting the total weight of the unit. An insufficient base may cause the unit to tip or fall.
- Ensure adequate ventilation space around the ice machine. Refer to the Clearance Requirements section for details.
- Only connect the ice machine to the electrical supply specified on the machine nameplate.
- The ice machine must not be connected to a hot water supply.
- The electrical outlet must be properly grounded and equipped with leakage protection.
- Disconnect the ice machine from the power supply before cleaning, servicing, or performing maintenance.
- Before performing cleaning or maintenance, remove all ice from the storage bin to prevent contamination.
- Do not spray or splash water directly onto the exterior or electrical components of the ice machine during cleaning. This may cause electrical shock, short circuits, or equipment failure.
- Flammable foaming agents are used in the insulation process. When disposing of the ice machine, it must be handled by qualified recycling personnel in accordance with local regulations.
- Ensure that children do not play with or operate the machine.
- If the ice machine malfunctions, turn off the power supply immediately and contact qualified service personnel.

Water Filters

The use of a water filtration system is strongly recommended. Water related issues and/or poor water condition will result in the loss of the manufacturer's warranty.

Water filters help ensure the water supplied to the ice machine is clean and free of sediment, which improves ice quality and reduces maintenance requirements.

Follow the installation and maintenance instructions provided by the water filter manufacturer.





LOCATION REQUIREMENTS

The installation location must meet the following conditions:

Electrical Supply

- Rated voltage must be within $\pm 6\%$ of the voltage indicated on the machine nameplate.

Water Supply

- Potable water only.
- Water pressure: 18 – 80 psig
- Water temperature: 41°F – 90°F (5°C – 32°C)

Environmental Conditions

- Keep the ice machine away from heat sources.
- Avoid locations exposed to direct sunlight or extremely high or low ambient temperatures.

Clearance Requirements

Adequate ventilation is required for proper operation. Minimum clearances:

Location	Minimum Clearance
Front	12 in
Sides	6 in
Rear	8 in

Floor Support

The floor must be capable of supporting the full weight of the ice machine and stored ice.

Electrical Safety

The electrical outlet must be: Properly grounded and equipped with leakage protection (GFCI where required).

Drainage

A floor drain must be available near the installation location to properly handle discharge water.

Installation Steps

1. Inspect the ice machine to ensure it was not damaged during transportation. Verify that all accessories and components are included.
2. Verify that the model number and electrical specifications on the nameplate match the installation requirements.
3. Clean the interior of the ice storage bin and food-contact surfaces using warm water and mild detergent. Rinse with potable water and dry thoroughly.
4. Place the ice machine in the designated installation location. Ensure the unit is positioned on a level surface so water flows properly into the evaporator.
5. The compressor compartment is located above the front of the ice storage bin and contains the compressor and condenser. Adequate ventilation must be maintained as noted above.
6. The ice machine is equipped with adjustable legs to allow proper leveling and provide clearance for floor cleaning.
7. Connect the water filter and inlet water line according to the filter manufacturer's instructions. If the installation site already has a suitable water filtration system, an additional filter may not be required.
8. Connect the water supply to the 3/4 in inlet fitting supplied with the machine. It is recommended to install a shut-off ball valve in the water supply line (not included).
9. Connect the drain line to the machine's drain outlet.



To ensure proper drainage:

- Maintain a minimum slope of 1 inch per 3 feet of drain line.
 - Ensure the drain line is not restricted or blocked.
 - It is recommended to connect the drain line to an open floor drain.
10. Ensure that no section of the drain line is higher than the machine's drain outlet.
 11. Verify that the electrical supply matches the specifications on the nameplate.
 12. The unit must be connected to a dedicated circuit breaker with proper grounding and leakage protection.
 13. Turn OFF the power supply switch before connecting the unit to the electrical source.
 14. Install the water filter in the correct flow direction, as indicated by the arrow on the filter housing.
 15. The water filter cartridge should be replaced every 3 to 6 months, depending on water quality and usage.
 16. Refer to the schematic diagram for electrical and refrigeration system layout.

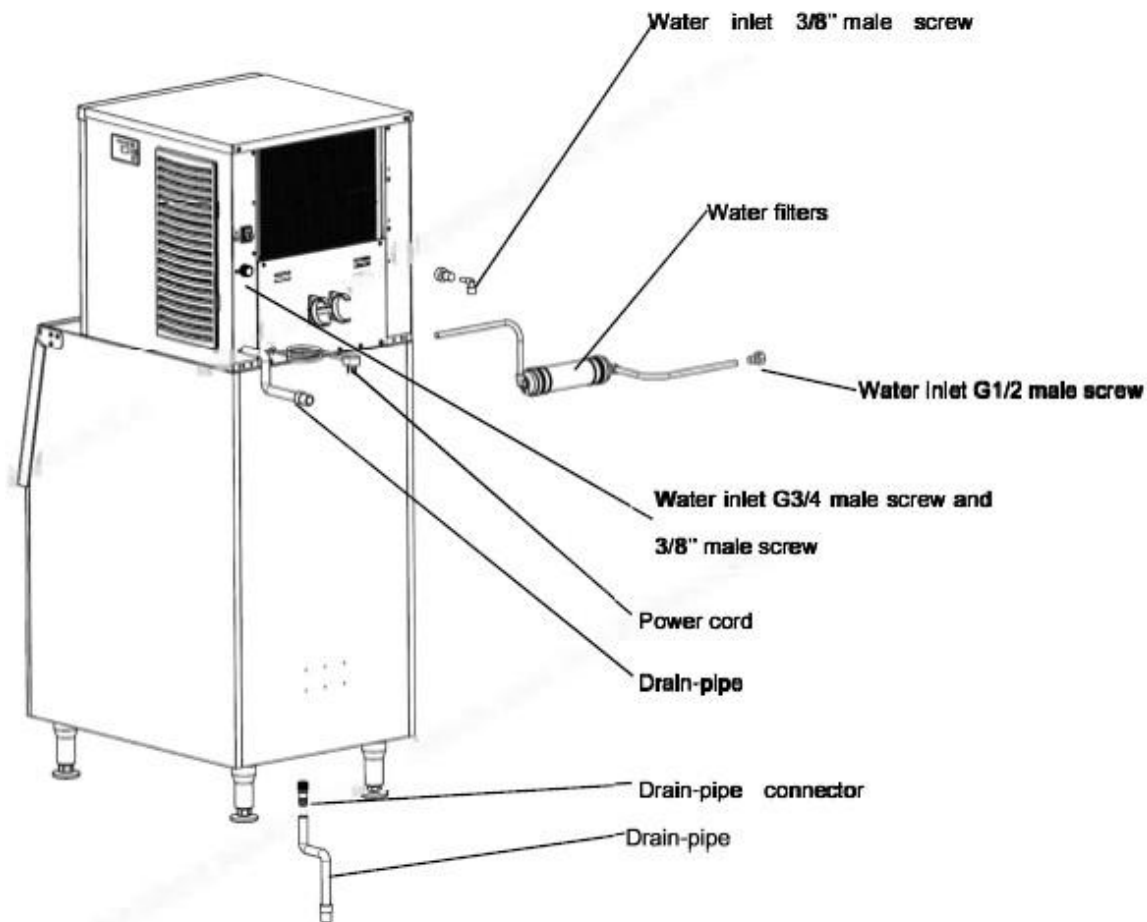

NOTE: *The installation plates and brackets used to attach the unit, and the bin together are not included.*

OPERATING INSTRUCTIONS

Start-Up

Before starting the machine, please verify the following:

- All packaging tape inside the ice machine has been removed.
- Accessories or items in the ice bin have been removed.
- The ice machine is level and stable.
- The water line is connected, and the water valve is open.
- The power plug is connected, and the power switch is OFF.
- Ambient temperature, water temperature, and water supply pressure meet the required specifications.

Starting the Machine

1. Turn on the power switch.
2. The machine will automatically begin the ice-making process.

Normal Operation Checks

Ensure the following conditions for proper operation:

- There is water in the water trough, with no overflow.
- The pump is working correctly, providing even water flow through the evaporator.
- The compressor is running normally; the temperature of the evaporator and ice-making water decreases gradually.
- For air-cooled machines: the fan operates correctly, and air flows steadily at both the inlet and outlet.
- The ice machine operates without abnormal noise or vibration.
- Ice production takes approximately 10–20 minutes per batch, depending on ambient and water temperatures. Higher temperatures may increase production time.
- Ice cubes are being properly harvested from the machine.

Operation Procedure

Startup

1. After installation, connect the water source and turn on the power supply.
2. Confirm that the machine operates normally during the first start-up.

Self-Check

- Upon initial power-on, the ice maker performs a self-check automatically.

Preparing

- After the self-check, the water valve opens and water floods the system.
- The machine will perform an initial defrost cycle.

Ice Making

- Following a 30-second pre-cooling period, the water pump starts.
- Water flows evenly through the evaporator, and ice cubes gradually form in the ice tray.

Ice Harvest (Drop)

- When ice-making is complete, the water pump turns off, and the defrost valve opens.
- Hot gas enters the evaporator for 1–2 minutes, allowing the ice cubes to slide into the storage bin.

Warning: Do not place your hands in the ice storage bin during the ice-fall process. Ice may cause injury.

Shutdown: Press the “Standby” button on the control panel to stop ice-making during operation.

Bin Full Stop

- When the ice storage bin reaches the preset level, the ice-making process stops automatically.
- A sensor located at the ice guide triggers this stop.
- To maximize storage capacity, spread ice evenly in front of the sensor.
- Once the ice level drops, the machine will resume ice-making within a few seconds.

Control Panel Instructions

1. LED Display

- Preparing: Counts seconds forward.
- Ice Making: Counts seconds forward; displays “Freeze”.
- Ice Harvest: Counts seconds forward; displays “Harvest”.

2. Ice Cube Thickness Adjustment

- During ice-making, if the ice thickness is not satisfactory, press the “Set/Clean” button, then use “Mode” or “Set/Clean” on the panel to adjust the ice thickness.
- Each press of “Mode” or “Set/Clean” adjusts ice-making time by ± 10 seconds, increasing or decreasing thickness accordingly.

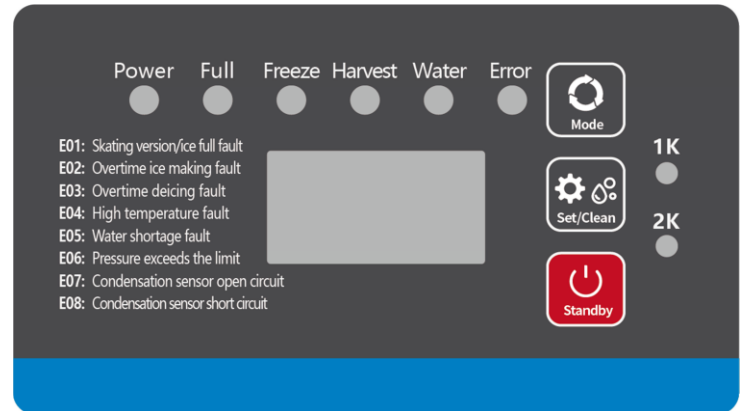

3. Cleaning

- During normal operation, press and hold “Set/Clean” for 6 seconds to enter the cleaning process.
- Add cleaning agents and disinfectants to the water tank as instructed.
- After cleaning is complete, the ice maker resumes ice-making automatically.

Note: Use only nickel-safe cleaning and sanitizing chemicals.

4. Standby

- Press the Standby button to switch the machine into standby mode.

5. Ice Bin Door

- Open and close the storage bin door gently.
- Do not slam the door.
- Keep the door closed when not removing ice.

6. Long-Term Inactivity

- If the ice maker will not be used for an extended period, energize and operate the machine for 2–4 hours every 2 months to maintain system integrity.

Special Protection – Automatic Shutdown

- If the ice machine does not detect ice harvest for three consecutive cycles, it will automatically shut down for safety. A service check is required.
- If the ambient temperature exceeds safe limits, the machine will stop automatically for protection.
- Fault codes and their descriptions are displayed on the control panel for troubleshooting.

Fault Codes

Code	Fault	Cause	Action
E01	Skating version / ice full fault	<ol style="list-style-type: none"> The ice guide is missing. The ice-full switch is faulty The magnetic induction element is reversed polarity 	Inspection and repair
E02	Overtime ice making fault	<ol style="list-style-type: none"> The ice is becoming too thick on the evaporator Hot gas valve is faulty The ice guide won't open Control board fault 	<ol style="list-style-type: none"> Verify compressor operation. Verify hot gas valve operation.
E03	Overtime deicing fault	<ol style="list-style-type: none"> The hot gas valve is faulty Then condensing temperature is low The ice set is too thin The water volume is too low 	<ol style="list-style-type: none"> Check the hot gas valve Circuit or water intake system
E04	High temperature fault	<ol style="list-style-type: none"> The fan motor is not functioning. Air filter or condenser is dirty Ambient temperature is too high 	<ol style="list-style-type: none"> Check if the fan blade is stuck, if not, please replace the fan. Please clean air filter or condenser
E05	Water shortage fault	<ol style="list-style-type: none"> No or low-pressure water supply Water valve may be faulty 	<ol style="list-style-type: none"> May need to replace your water filter cartridge. Otherwise, there is an issue with your incoming water line. Check if the water inlet light flashes. For new machines, when you restart the machine please check if the water inlet light flashes. If not, it does not and there is no water in the water tank, please replace the water valve. If it flashes but there is little or no water in the water tank, please check the water source, there may be no water supply, or the water filter is blocked
E06	Pressure exceeds the limit	The condensation temperature is too high or the cooling system is blocked	<ol style="list-style-type: none"> Check if the fan does not work, if the cooling fan works properly, the high pressure switch may be faulty. Use a multimeter to measure the on/off status of the pressure switch. Check if the cooling system is blocked.
E07	Condensation sensor is open circuit	The sensor is damaged or the connector is faulty	Verify probe wires have a good connection in the controller by disconnection probe leads from the controller and reconnecting leads to controller. Use a multimeter set to Ohm setting and verify resistance value of the probe in 77°F hot water. Value should be within 10 kΩ±1%.
E08	Condensation sensor short circuit	The Sensor is damaged or the connector is faulty	Verify probe wires have a good connection in the controller by disconnecting probe leads from controller and reconnecting leads to controller. Use a multimeter set to Ohm setting and verify resistance value of the probe in 77°F hot water. Value should be within 10kΩ±1%.



MAINTENANCE

NOTE: Maintenance must be performed by a qualified technician.

WARNING: Before performing maintenance or manual cleaning, shut off both the water supply and power to the ice machine.

1. Exterior Cleaning

- Keep the environment around the ice machine clean and free of debris.
- Do not block ventilation openings.
- Clean the outer enclosure with a mild detergent and wipe thoroughly.
- For stainless-steel surfaces, commercial stainless-steel cleaners or polishes may be used.

Note: Stainless steel may rust if not properly maintained.

2. Water Filter

- If the ice machine has a water filter installed, inspect it regularly.
 - Replace the filter cartridge every 3–6 months or as recommended by the filter manufacturer.
-

3. Interior Cleaning

- Wash the interior of the ice storage bin with water and cleaner solution, then rinse thoroughly with clean water.
- Repeat with a water and sanitizer solution to ensure proper disinfection.

Note: Ensure that the water pressure does not exceed the maximum allowed. Avoid flushing the water pump or evaporator directly to prevent damage.

4. Condenser (Air-Cooled Machines)

- Clean the condenser monthly using a soft brush or a vacuum cleaner with a brush attachment. Brush along the direction of the fins to prevent damage and maintain cooling efficiency.
- Clean the condenser filter every 2 weeks.

Note: Fin edges are sharp; use caution when cleaning.

5. Water Pipe Cleaning

- To maintain food safety, the water pipes should be cleaned regularly according to recommended schedules.
-

6. Winterizing

- Turn off the water supply and power.
- Drain residual water from the water trough, inlet pipe, and drain-pipe.

NOTE: Any maintenance or damage caused by improper winterization is excluded from coverage under the manufacturer's warranty.





7. Monthly Clean Function

Preparation:

- Empty the ice storage bin in advance.
- Clean and sanitize the bin, then rinse thoroughly.
- Clean and sanitize the ice guide, water pipe, and water pump, then rinse completely.

Cleaning Process:

1. Turn on the ice maker.
2. Press and hold the "Set/Clean" button for 6 seconds to begin the cleaning cycle.
3. The water valve will run for 85 seconds (time adjustable) until the normal working water level is reached.
4. Pour the appropriate amount of cleaning liquid into the water tank and spray over the evaporator for thorough cleaning.
5. The water pump runs for 15 minutes. After 5 minutes, manually add the proper amount of disinfectant into the water tank and spray over the evaporator.
6. Both the pump and water valve continue running for 15 minutes.
7. The ice maker enters the rinsing process automatically.
8. After the cleaning process is completed, the machine resumes ice-making.

Note: Use only nickel-safe cleaning and sanitizing chemicals.



Monthly Manual Cleaning & Sanitizing

Attention: Monthly Manual Cleaning & Sanitizing must be carried out by the manufacturer, its service agent or similarly qualified people.

Cleaning Instructions

1. Remove all ice from the ice bin to avoid contamination.
2. Remove the door.

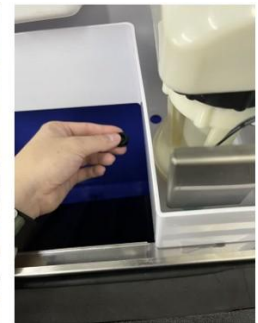
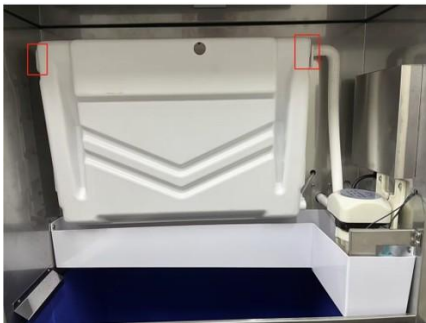

3. Empty the water from the tank.



4. Remove the pump and pull out the upper pipe of the pump circulation.

5. Remove screws which are securing the spray pipe. Remove the spray pipe and the upper pipe.



6. Disassemble fixed screws which are in the spray pipe. Dismantle the spray pipe.



7. Mix a solution of nickel-safe cleaner and water according to your ice machine cleaner instructions. Ensure the cleaning agent dissolves completely. Soak the water pipe, inlet and outer spray pipe, head, spray pipe fixing seat and screws, etc. in the cleaning solution for 5 minutes (or 15 minutes for heavily scaled components). Rinse all components thoroughly with clean water.



8. After soaking, scrub the spray pipe, water curtain and pump base bracket with cleaning solution, and rinse with clean water.



9. Spray the cleaning solution into the evaporator and wipe clean. Repeatedly wipe the water tank, ice plate and its plastic parts, side plates, ice buckets and other sanitary areas with cleaning solution. Rinse all areas thoroughly with clean water.



Disinfection Instructions

Prepare Disinfectant Solution

- Mix the disinfectant with water according to the manufacturer's instructions for ice machine use.
- Ensure the disinfectant is completely dissolved.
- Soak the following components in the solution for 5 minutes:
 - Water pipe
 - Inner and outer nozzle
 - Head nozzle base
 - Screws
- If using a no-rinse disinfectant, flushing after soaking is not required.
- Disinfect Spray Pipe, Ice Guide, and Pump Support
- Apply disinfectant to the spray pipe, ice guide, and pump support.



Note: For no-rinse disinfectants, additional flushing is not required.



Spray Disinfectant

- Using a spray bottle, apply disinfectant to the evaporator and its plastic components.
- Spray the water tank, ice bin, and other sanitary surfaces.

Note: If using a no-rinse disinfectant, rinsing is not required.

Dry and Reassemble Components

- Allow the dismantled spray pipe, water pump, water pipe, and ice-guide to dry completely.
- Reinstall all components to their original positions once dry



Attention When Servicing Systems with Flammable Refrigerants

1. General Requirements

Service shall only be performed as recommended by the manufacturer.

All maintenance, service, or repair work affecting safety shall be carried out only by qualified and competent personnel.

Examples of work procedures requiring qualified personnel include:

- Breaking into the refrigerant system
- Opening sealed components
- Opening ventilated enclosures

2. Area Safety Checks

Before starting work on systems containing flammable refrigerants, perform safety checks to minimize the risk of ignition.

Work Procedures

- All work must be carried out using controlled procedures to reduce the risk of flammable gas or vapor being present during servicing.

Work Area

- All personnel in the work area must be informed about the nature of the work being carried out.
- Work in confined spaces should be avoided whenever possible.

Refrigerant Detection

- The area must be checked with an appropriate refrigerant leak detector before and during service work.
- Ensure the leak detection equipment:
 - Is suitable for the refrigerant used
 - Is non-sparking
 - Is properly sealed or intrinsically safe

3. Fire Prevention

Fire Extinguishers

If hot work is required, suitable fire extinguishing equipment must be available nearby.

Recommended types:

- Dry chemical extinguisher
- CO₂ fire extinguisher

Ignition Sources

Do not use any ignition sources when working on refrigerant systems.

This includes:

- Open flames
- Sparks
- Smoking

“No Smoking” signs must be displayed in the work area.





4. Ventilation Requirements

Ensure the work area is: Outdoors, or Adequately ventilated

Ventilation must remain active throughout the servicing process to safely disperse any released refrigerant.

5. Equipment Checks

When working on refrigeration equipment:

- Replacement electrical components must meet manufacturer specifications.
- Always follow the manufacturer's maintenance guidelines.

Verify the following:

- Refrigerant charge is appropriate for the room size.
- Ventilation systems are operating correctly and are not obstructed.
- Refrigerant markings and labels remain visible and legible.
- Refrigerant piping is protected from corrosion or damaging substances.

6. Electrical Safety Checks

Before servicing electrical components:

- Disconnect electrical power.
- Inspect components and wiring.

Initial safety checks must include:

- Capacitors are properly discharged.
 - No live electrical wiring is exposed.
 - Proper grounding (earth bonding) is present.
- If a safety fault is discovered, do not reconnect power until the issue is corrected.

If temporary operation is necessary, the equipment owner must be informed of the risk.

7. Servicing Sealed Components

Before removing sealed covers:

- Disconnect all electrical power.

If power must remain connected during servicing:

- A continuous leak detection system must be installed at the most critical point.

Also ensure:

- Cables are not damaged
- Terminals match original specifications
- Seals and glands are intact
- Equipment is mounted securely

Replacement parts must be Original Equipment Manufacturer (OEM), parts to maintain warranty, certification and product liability.

8. Intrinsically Safe Components

Only intrinsically safe components may be serviced while energized in the presence of a flammable atmosphere.

Do not add inductive or capacitive loads that exceed the permitted voltage or current limits.

Only use manufacturer-approved replacement components.





9. Cabling Inspection

Check wiring for:

- Wear
- Corrosion
- Excessive pressure
- Vibration
- Sharp edges
- Environmental damage

Also consider long-term effects such as vibration from compressors or fans.

10. Refrigerant Leak Detection

Never use open flames to detect refrigerant leaks.

The following methods are acceptable:

- Electronic leak detectors (properly calibrated)
- Approved leak detection fluids

Avoid detergents containing chlorine, as they may corrode copper piping.

If a leak is suspected:

- Extinguish all flames immediately.
-

11. Refrigerant Removal and Evacuation

When opening the refrigerant circuit:

- Recover refrigerant according to local regulations.
- Purge the system with oxygen-free nitrogen.
- Evacuate the system if required.
- Repeat purging if necessary.
- Open the circuit by cutting or brazing.

Never use compressed air or oxygen for purging refrigerant systems.

12. Charging Procedures

When charging refrigerant:

- Prevent mixing different refrigerants.
- Keep hoses as short as possible.
- Position cylinders properly.
- Ensure the refrigeration system is grounded.

Additional steps:

- Pressure test before charging
- Leak test after charging
- Perform a final leak test before leaving the site

Avoid overfilling the system.





13. Decommissioning

Before decommissioning:

- Ensure the technician understands the equipment and its operation.
- Safely recover all refrigerant.

Procedure:

1. Disconnect electrical power.
2. Verify recovery equipment and cylinders are available.
3. Wear appropriate personal protective equipment (PPE).
4. Recover refrigerant using approved recovery equipment.
5. Do not fill recovery cylinders beyond 80% capacity.
6. Remove cylinders and equipment promptly after recovery.

Note: Recovered refrigerant must not be reused unless it has been properly cleaned and tested.

14. Equipment Labelling

After decommissioning:

- Label equipment indicating it has been emptied of refrigerant.
- Labels must include the date and technician signature.

Equipment containing flammable refrigerants must also have clear warning labels.

15. Refrigerant Recovery

When removing refrigerant:

- Use approved recovery cylinders designed for the specific refrigerant.
- Ensure cylinders have pressure-relief valves and shut-off valves.
- Recovery cylinders should be evacuated before use.

Recovery equipment must:

- Be in good working condition
- Be suitable for flammable refrigerants
- Include calibrated weighing scales

Recovered refrigerant should be returned to the refrigerant supplier following proper waste transfer procedures.

Do not mix refrigerants.

16. Compressor and Oil Removal

If compressors or oil are removed:

- Evacuate refrigerant from the system first.
- Ensure no flammable refrigerant remains in the lubricant.

Only electric heating of the compressor body may be used to assist evacuation.

Oil must be drained safely.





CALLING FOR SERVICE

If the ice machine does not operate properly, please verify the following items before requesting service.

1. Check the Water Supply

- Ensure water is present in the water trough.
- Confirm that the water pressure is 18–80 psig and the water temperature is 41°F–90°F (5°C–32°C).
- Verify that the water supply valve is fully open.
- Check for any visible water leaks.

2. Check the Power Supply

- Confirm that the display panel indicator is ON.
- Ensure the control panel is not in OFF or standby mode.
- If the display LED is not illuminated:
 - Check that the power plug is properly connected.
 - Verify that the electrical outlet is functioning.
 - Ensure the main power switch is turned ON.

3. Check the Nameplate and Serial Number

Locate the nameplate on the side or rear of the ice machine and record the model number and serial number before contacting service.

Important Notice

Service calls may be chargeable if the problem is caused by user-related factors, including:

- Failure to maintain or replace the water filter
- Lack of water supply or electrical power
- Improper environmental conditions
- Improper operation or maintenance





Troubleshooting

Problem or Code	Comments	Machine Action
Not working	Power switch not turned on	Turn on the power switch
Indicator is OFF	Plug is loose	Check plug and socket
Shutdown every 3 minutes after startup	The ambient temperature is too high	Normal working temperature range of 41°F-100°F
The display shows E04 high temperature	Condenser is dirty and blocked high pressure switch wires fallen off	Clean the condenser
The display shows E06 high pressure protection	Fan does not start	Check and correct high pressure switch wires
Ice defrosts abnormal	Ambient temperature too low	Normal working temperature range of 41°F-100°F
	Defrost valve does not start normally	Check and correct the defrosting valve
	Ice thickness too thin or too thick	Check and correct ice thickness setting
Poor transparency of ice cubes; ice cubes too thin or incomplete	Ice thickness is too thin	Check and correct ice thickness setting
	Water pressure is too low	Check that the water supply pressure is 18 psig to 80 psig
	Inlet water valve is dirty and blocked	Normal working temperature range of 41°F-100°F
	inlet water filter has not been replaced for a long time	Check and correct the inlet water valve
	Inlet water valve is dirty and blocked	Check whether water leaks and correct
	Water leaking	Check and correct the inlet water filter and water connection
	Inlet water filter has not been replaced for a long time	
Too slow in ice making	The condenser or air filter is dirty	Clean the condenser and filter screen
	High ambient temperature	Normal working temperature range of 41°F-100°F
	Poor ventilation	Check the environment around the ice machine
	Water temperature is too high	Check the water supply temperature of 41°F-100°F
Too much noise	The ice machine is not placed in a level foundation, or the ice maker is not leveled	Level the ice machine





This page left blank intentionally.





This page left blank intentionally.





This page left blank intentionally.





ENTRÉE LLC
4673 OSBORNE DRIVE SUITE D
EL PASO, TX 79922

Warranty Service- Technical Support
(704) 900 2068
techsupport@entree.biz



Intertek



Intertek

For Ice Cube Machine Warranty Statement please visit our website: www.entree.biz



For warranty service, call (704) 900-2069