



COMMERCIAL HEAVY DUTY GAS COUNTERTOP CHARBROILER

SHDB-2430 SHOWN



Features

- Key components have CSA/ETL certificate
- 4" adjustable stainless-steel legs (removed for packaging to prevent concealed damage and lower shipping costs.)
- Equipped with convertible appliance regulator (Maximum pressure 1/2 P.S.I.)
- Gas conversion kit shipped standard, to convert to appropriate incoming gas.
- Cast iron grill grates are reversible.
- 4" Back and Side splash guards
- Full width crumb tray easily removed for cleaning.
- Infinite valve control
- 3/4" NPT Rear gas connection

SHDB-1430

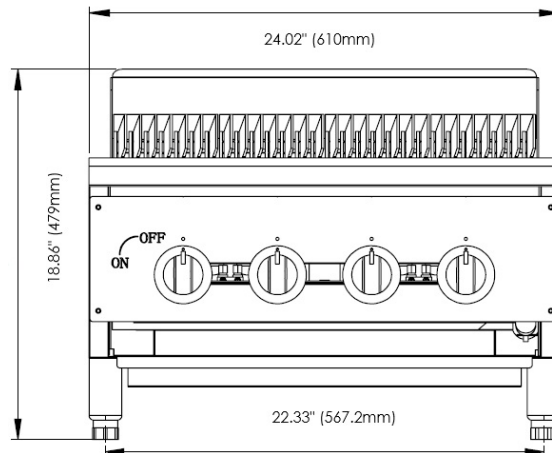
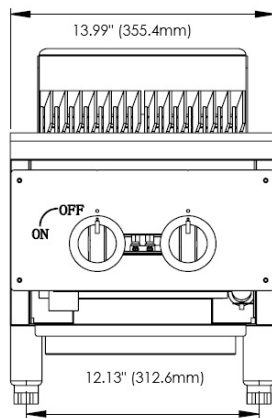

SHDB-2430

Model	# of Burners	Total BTU's	Cooking Surface		Product Dimensions			Net Weight (lbs.)	Shipping Dimensions			Gross Weight (lbs.)
			Width	Depth	Width	Depth	Height		Width	Depth	Height	
SHDB-1430	2	40,000	10.63"	21.46"	13.99"	31.78"	18.82"	120	17.72"	35.43"	22.05"	145
SHDB-2430	4	80,000	21.26"	21.46"	24.02"	31.70"	18.86"	198	29.13"	35.43"	22.05"	240

Warranty: Solaris's exclusive 1 year parts and labor FUSS warranty takes effect from date of purchase.

***Not suitable for installation in a non-commercial or residential applications.**

Customer Service (704) 900-2068
 Email: solaris@entree.biz
 Website: www.entree.biz/solaris



COMMERCIAL COOKING



COMMERCIAL HEAVY DUTY GAS COUNTERTOP CHARBROILER

A convertible 3/4" NPT appliance pressure regulator is provided with this unit and set for:
 Natural Gas 4.0" W.C.
 Propane Gas 10.0" W.C.

Rear Gas Connections is 3/4" NPT
 Recommended incoming pressure:
 Natural Gas 5.0" W.C. with not more than a 1/2" W.C. pressure drop
 LP Gas 11.0" W.C. with not more than a 1/2" W.C. pressure drop

SHDB-3630

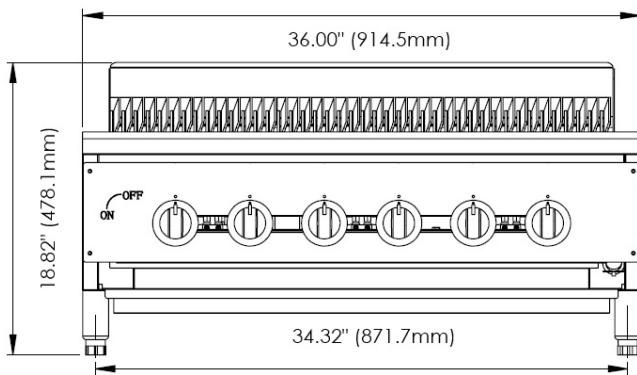

Side View All

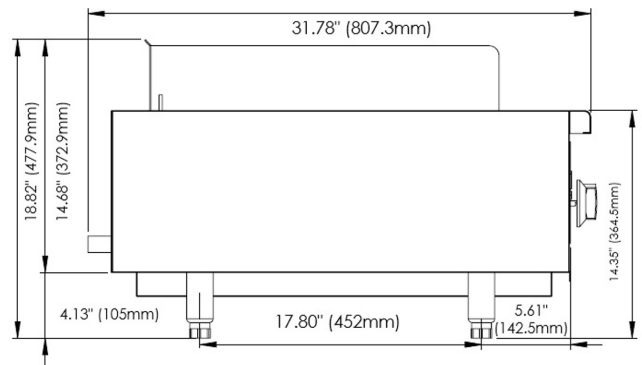

Gas connection:
 From the right rear
 side of all models

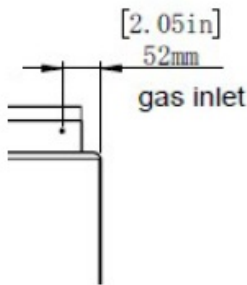

SHDB-4830

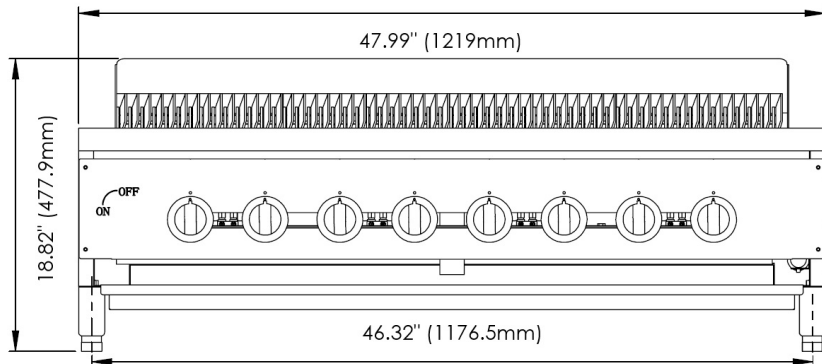

Model	# of Burners	Total BTU's	Cooking Surface		Product Dimensions			Net Weight (lbs.)	Shipping Dimensions			Gross Weight (lbs.)
			Width	Depth	Width	Depth	Height		Width	Depth	Height	
SHDB-3630	6	120,000	31.89"	21.46"	36.00"	31.78"	18.86"	283	40.94"	35.43"	22.05"	338
SHDB-4830	8	160,000	42.52"	21.46"	47.99"	31.78"	18.82"	364	52.76"	35.43"	22.05"	429

***Not suitable for installation in a non-commercial or residential applications.**

Customer Service (704) 900-2068
 Email: solaris@entree.biz
 Website: www.entree.biz/solaris

As continued product improvement is a policy of Solaris, specifications are subject to change without notice.

FORM SHDR Rev 20260206



COMMERCIAL COOKING