

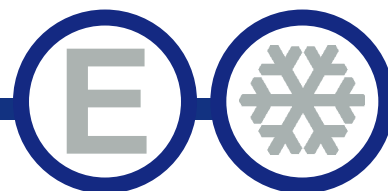

Refrigeration "HC"



Solid Door Refrigerators & Freezers



CR1-19-HC / CF1-19-HC



CR2-35-HC / CF2-35-HC

Model
CR1-19-HC
CR2-35-HC
CF1-19-HC
CF2-35-HC

STANDARD FEATURES

- CFC Free Refrigerant and foam
- For stainless steel interior add "-SI", example: CR1-19-SI-HC.
- Solid state thermostat with digital display
- Stainless steel front and sides
- Field reversible 1-door units
- Self-closing doors remain open past 90°
- Non twist solid mullions on 2 & 3 door units
- Environmentally friendly HC R290
- EZ slide-out-condenser
- Stainless steel door handle
- Whisper quiet
- Solid construction
- High efficiency polyurethane insulation
- Zero clearance sides and 2" back
- 2 Year Parts and Labor Warranty, additional 3 years on compressor.

*Not suitable for installation in a non-commercial or residential applications.

Items	Description	Items	Description
Front, Top & Sides	430 Stainless steel	Temperature control	Solid State T-stat with Digital Display
Door	430 Stainless steel	Comply to standard	ETL Listed
External back	430 Stainless steel	Refrigerating system	Capillary tube
Cabinet internal	Powder Coated Aluminum	Refrigerant	R290
Internal floor	304 Stainless steel	Temperature Range	(CR) 34°F — 38°F (CF) -11°F -1°F
Insulation	Polyurethane (CFC free)	Evaporator/Condenser	Aluminum + Copper
Shelves	Heavy duty, PVC coating – 3 or 4 layers	Condensing unit	Bottom Mounted

REFRIGERATION / FREEZERS



DETAILS AND DIMENSIONS

CR1-19-HC / CF1-19-HC

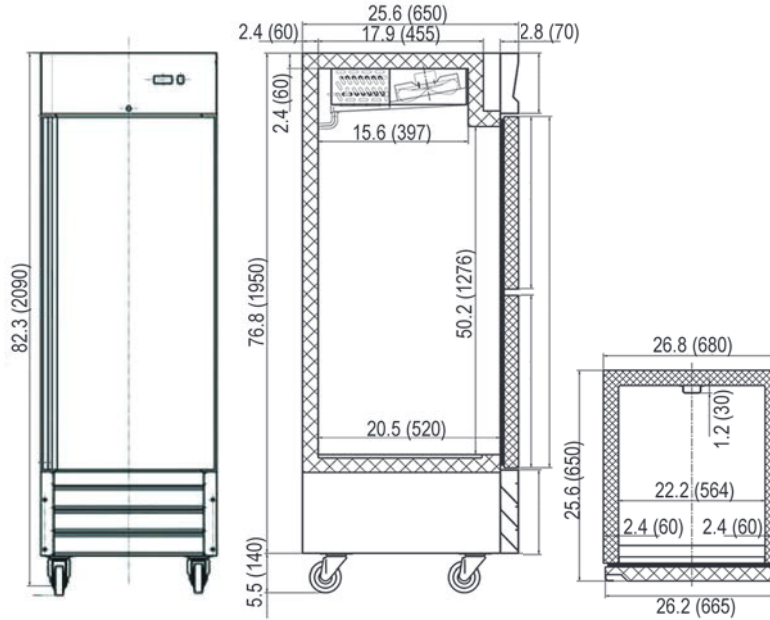

CR2-35-HC/ CF2-35-HC

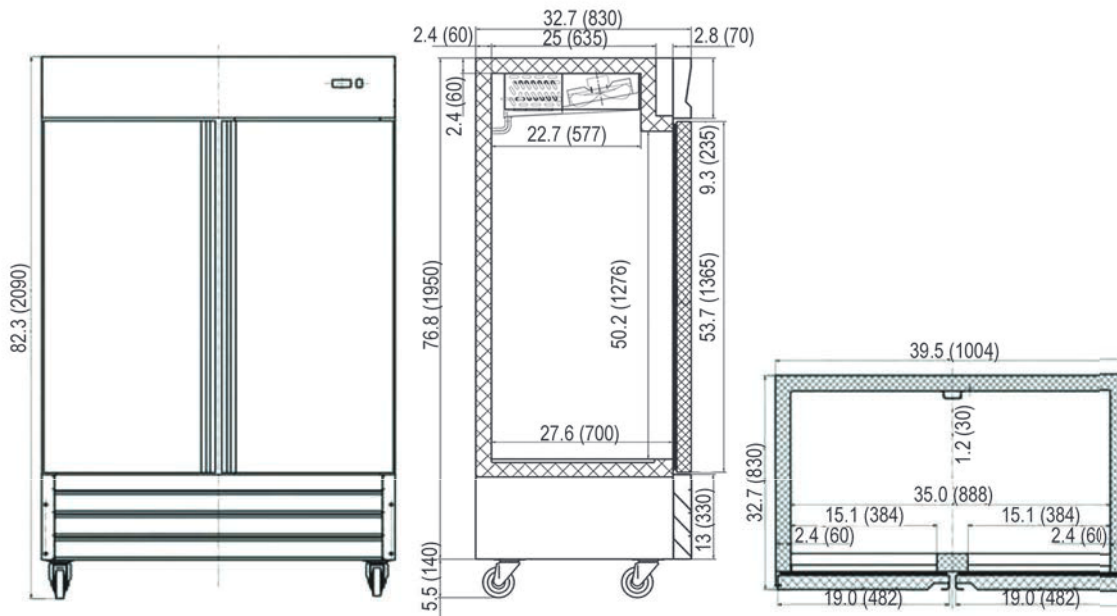

Model	Doors	Shelves	Cabinet Dim (in) External			HP	Voltage Hz/Ph	Amp	NEMA Plug	Cord Length (ft)	Crated Weight (lbs)
			W	D	H						
CR1-19-HC	1	3	26.8	25.6	82.3	1/5	115/60/1	3	5-15P	9.8	220
CF1-19-HC	1	3	26.8	25.6	82.3	1/2	115/60/1	5	5-15P	9.8	225
CR2-35-HC	2	6	39.5	32.7	82.3	1/4	115/60/1	4.5	5-15P	9.8	313
CF2-35-HC	2	6	39.5	32.7	82.3	1	115/60/1	9	5-15P	9.8	320