

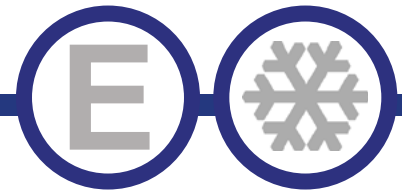

# Series "B"



## MERCHANDISER REFRIGERATOR



EGM21X

Model	Doors
EGM21X	1
EGM26X	1
EGM28X	1

EGM26X



EGM28X



### STANDARD FEATURES

- Exterior: Coated steel. Black or white or Stainless steel finish available.
- Interior: Attractive aluminum liner with stainless steel floor.
- Refrigeration system maintains temperatures between 33°F and 41°F.
- Self-Closing double pane glass door with positive seal.
- Shelves: Adjustable heavy-duty PVC coated shelves.
- Electronic control system makes it easy to adjust temperature set point and defrost frequency.
- Easy to access condenser coil for cleaning and service.
- Uses R290 refrigerant, which is Eco friendly and more efficient.
- Interior efficient LED lighting.
- EGM21X and EGM26X, no casters are provided, leveling feet only. 3" Swivel Casters are pre-installed on EGM28X
- Warranty: Two year parts & labor warranty, and additional 3 years on compressor.

\*Not suitable for installation in a non-commercial or residential applications.

Items	Description	Items	Description
Front, top & sides	Coated steel	Temperature control	Solid state thermostat/Digital display
Doors	Double Pane Glass Swing	Approvals	ETL Listed
External back	Coated steel	Refrigerating system	Capillary tube
Cabinet interior	Aluminum	Refrigerant	R290
Interior floor	Stainless steel	Temperature range	33°F to 41°F
Insulation	Polyurethane (CFC free)	Evaporator	Powder coated aluminum/copper
Shelves	Heavy duty, PVC coating	Condensing unit	Bottom mounted

CONFORMS TO NSF/ANSI STD 7

REFRIGERATION



# DETAILS AND DIMENSIONS

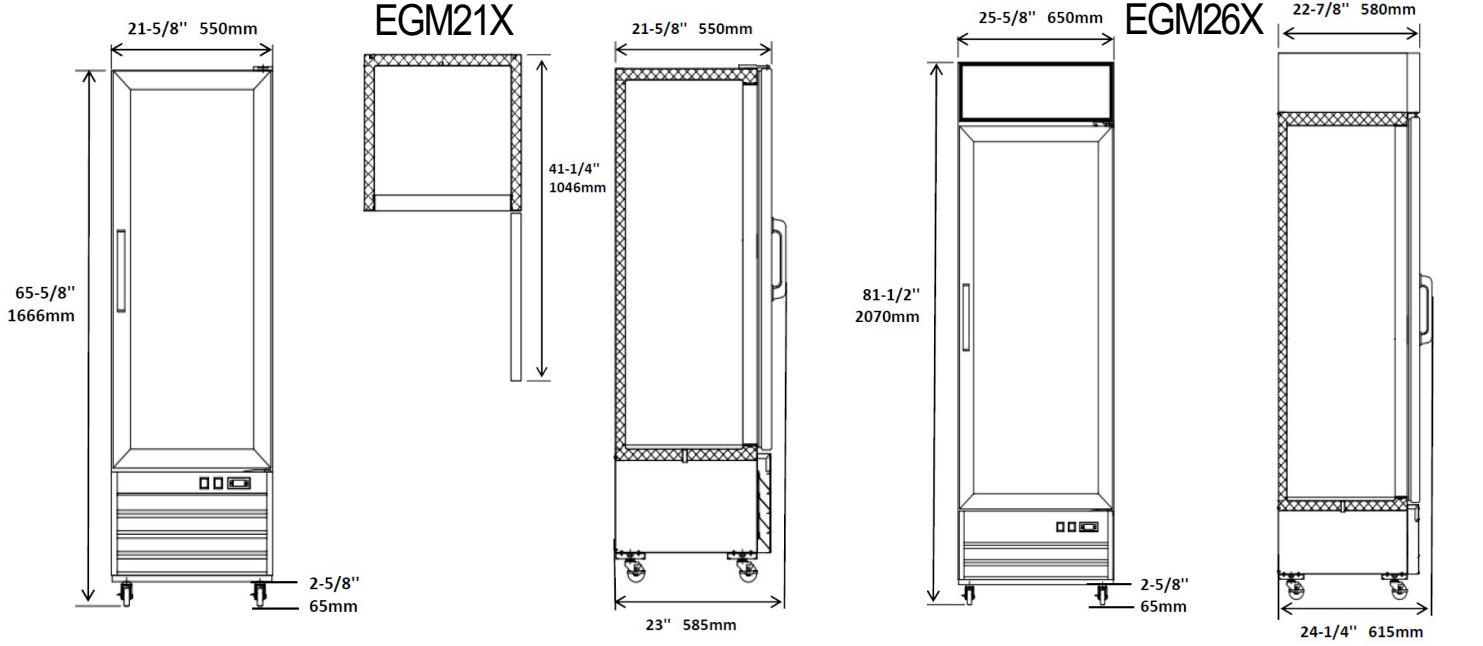

EGM28X

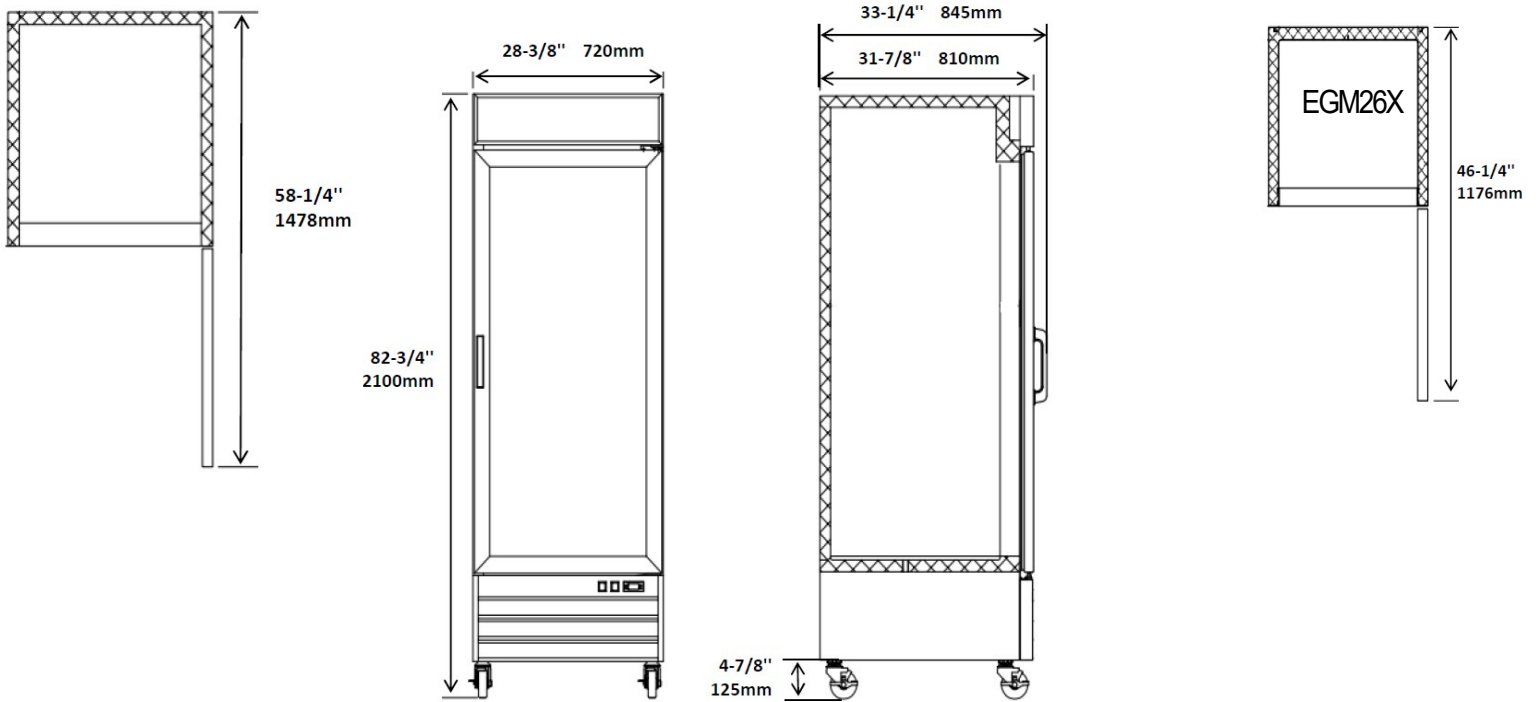

Model	Doors	Shelves	Cabinet Dim (inches)			HP	Voltage	Amps	NEMA Plug	Cord Length	Crated Weight
			L	D	H						
EGM21X	1	4	21.625	21.625	65.625	1/5	115/60/1	2.88	5-15P	10	209
EGM26X	1	4	25.625	22.875	81.5	1/5	115/60/1	2.88	5-15P	10	279
EGM28X	1	4	28.375	31.875	82.75	1/5	115/60/1	3.0	5-15P	10	319