



Important information

Please fill in the following information and keep this manual for future use.

Model:

Serial number:

Installation Date:

Electric Counter Steamer Installation and User manual

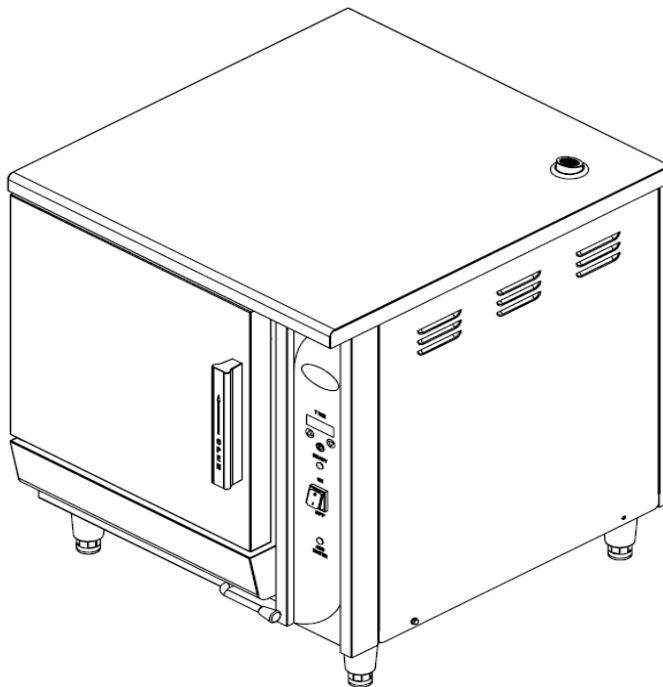

Model:

SCS-3-208

SCS-3-220

SCS-3-240

SCS-5-208

SCS-5-220

SCS-5-240

P/N:

Version B

August 2024

Product specifications or technical parameters are subject to change without prior notice

Safety symbols



DANGER!

This symbol highlights dangerous situations which lead to serious injury or death



WARNING!

This symbol highlights potential dangerous situations which could lead to serious injury or death



CAUTION!

This symbol highlights potential dangerous situations which lead to minor injury



DANGER!

Be careful. Life is at risk. Failure to comply may result in electrical shock



The safety self-adhesive label "maximum insertion height for liquid filled container" is included in the installation package. After the installation of the equipment, please attach the label to the equipment 1.6 meters above ground level.

IMPORTANT SAFETY INSTRUCTIONS

This manual should be handed over to end user, along with the equipment. The end user must read this manual carefully and be familiar with each function and operation. This book must be placed close to equipment for the operators to use for reference.

Recommend you to sign a contract with the maintenance service provider authorized by manufacturer.

 **Warning!**

For your safety, do not store or use gasoline or other flammable or volatile items in or beside the steamer.

 **Warning!**

Improper installation, commissioning, modification, repair or maintenance of the steamer may lead to property loss, life injury or even fatal danger. Please read the installation, operation and maintenance instructions carefully before installation or maintenance.

 **Warning!**

Circuit diagrams and user manual are packed in the package.

 **Important!**

The user is responsible for any visible or hidden damage to the equipment found during the unpacking process and claim with the shipping company.

User should keep all shipping documents until it is confirmed that the equipment has not suffered any damage.

 **Notice!**

The use of any non-manufacturer produced steamer parts will result in the warranty being void.

 **Notice!**

The manufacturer reserves the right to change the product specifications at any time.

 **Notice!**

The installation and commissioning of the steamer should be done by a suitably qualified engineer. Installation should adhere to all local and national regulations.

 **Notice!**

Only qualified personnel trained by manufacturer can conduct installation and service the steamer.

 **Notice!**

This appliance is designed for commercial kitchens. Staff must be properly trained before operating this equipment.

 **Caution!**

This appliance is NOT intended for use by persons (including children) with reduced physical, sensory or mental capabilities, or having lack of experience and knowledge.

 **Warning!**

If there is any damage in the power cord, switch off the steamer immediately. DO NOT USE THE STEAMER. Get a suitably qualified technician or service engineer to replace the power cord before reusing the steamer.

 **Warning!**

Disconnect the steamer from the power supply before repair, maintenance or cleaning.

 **Warning!**

The appliance must not be powered by an external switching device, such as a timer, or connected to a device that is regularly switched on or off.

 **Warning!**

Do not use a water jet or spray hose to clean this appliance.

 **Warning!**

Do not attempt to move the steamer or transfer hot liquid from one container to another when the device is at cooking temperature or filled with hot liquid.

 **Warning!**

Do not sit or stand on the steamer. Do not step on the front panel, door and top of the appliance. Slipping, falling or contacting with hot liquid or hot surface may cause serious injury.

 **Warning!**

Do not use this equipment as a step for cleaning or entering the ventilation hood. Slipping, tripping or contact with hot liquid or hot surface may cause serious injury.

 **Warning!**

Do not turn on drain switches or other emptying devices until the pressure is reduced to near atmospheric pressure.

 **Warning!**

In order to avoid scalding, do not use containers to fill food that needs to be heated at a higher temperature to become liquid than food that is easily become into liquid.

 **Warning!**

Steam may come out when the door is opened. To avoid steam burns, open the door slightly (this allows some steam to escape). Then open the door fully. Take care at all times when opening the steamer door.

 **Warning!**

The appliance is intended to be used for commercial purposes, such as restaurants, canteens, hospital kitchens and commercial enterprises such as bakeries and meat shops, but not for continuous mass production of food.

 **Warning!**

This equipment is intended for indoor use only.

 **Warning!**

Do not operate the steamer unless all panels and access covers are properly attached.

 **Warning!**

It is recommended that the performance and operation of the equipment be inspected annually by a qualified maintenance technician.

Save it for future reference

Safety symbols	2
1. Introduction	7
1.1 Main function	7
1.2 Steamer features	7
1.3 Maintenance	7
1.4 Assistance	7
1.5 Safety	7
2. Installation	8
2.1 Introduction	8
2.2 Unpacking	9
2.3 Installation space requirements	9
2.4 Ventilation	9
2.5 Power supply requirements	9
2.6 Power supply installation	10
2.7 Water supply connection	11
2.8 Dimension	12
2.9 Pan sizes	14
3. Instruction	15
3.1 Position and function of the controller	15
3.2 Description	15
4. Cleaning and maintenance	17
4.1 Cleaning and maintenance steps	17
5. Trouble shooting	18

1. Introduction

1.1 Main function

The electric steamer adopts the continuous pressure maintaining technology. The cooking process can ensure the molecular structure of the food itself, without water and nutrient loss, and retain the original nutrients of the food. The steam is used to heat the food to achieve the purpose of warming, thawing or steaming.

1.2 Steamer features

- High efficiency heating elements
- Chamber pressure maintaining
- Multiple protection

1.3 Maintenance

Like other food equipment, electric steamer needs to be maintained and cleaned as part of daily maintenance.

1.3.1 Turn off the power switch and open the steamer door every day. When the water in the water tank of chamber is cooled, clean the water tank with neutral detergent to ensure that the drain outlet and drain valve are smooth;

1.3.2 Wipe the sealing rubber of door and the front frame of the chamber every day;

1.4 Assistance

If you need any assistance, please contact our distributor or the technical support department.

1.5 Safety

Safety is an important feature of our products. Proper installation, operation and maintenance is the only way to ensure safety.

1.6 Discard device correctly



The correct product disposal method (recycling of electronic and electrical products) in the European Union and other European countries is the waste separation and recycling system. If the symbol on the left

side appears on the product or description, it means that the product cannot be disposed of with other household waste at the end of its service life. In order to prevent uncontrolled garbage disposal that may cause harm to the environment or personal safety, please separate such garbage from other garbage for recycling and promote the recycling of resources. Household users can consult the retailer selling this product or the relevant local government department for environmentally sound recycling of such products. Commercial users need to consult the supplier and check the relevant terms of the purchase contract, this product can not be disposed of with other commercial waste.

2. Installation

 **Warning!**

Please do not install, move or repair the equipment by yourself, otherwise our company will not be responsible for the warranty and security responsibilities.

 **Warning!**

Relevant protective measures must be taken when operating the Steamer.

 **Warning!**

The equipment line must be reliably grounded and equipotential terminals are recommended to be connected.

 **Warning!**

It is highly recommended to install the leakage protector, and confirmed by the professional and technical personnel of the installation company designated by our company.

 **Warning!**

Do not install the equipment in places with flammable products, explosive or corrosive gases, dust, etc.

2.1 Introduction

This chapter provides the installation method of electric steamer.

 **Notice!**

Installation needs to be done by suitably qualified personnel.

 **Danger!**

Do not drill holes in the shell of the machine with a pistol drill or screw, which may damage the structure or cause electric shocks .

2.2 Unpacking

The Steamer has been checked and tested in the factory and is packed on a wooden pallet with a strong packing box and lining board, which can withstand the normal transportation bumps.

Notice!

Any damage found before unpacking should be reported to the transport company in writing upon delivery.

2.3 Installation space requirements

The left and right sides of the steamer should have at least 75mm space, the back of the steamer should have at least 100mm space, the front of the steamer should have at least 900mm. When maintenance, both sides of the steamer need to have 460mm space, if there are other cooking equipment on both sides of the steamer, you need to have 600mm space.

2.4 Ventilation

The steamer should be equipped with ventilation equipment such as exhaust fans to ensure that the odor and steam caused by cooking food can be discharged in time, and avoid affecting the operation. We recommend you to find a professional company to install exhaust equipment.

2.5 Power supply requirements

Refer to the following parameters:

Model	Voltage (V)	Phase	Power (kW)	Current (A)
SCS-3-208	208	1/3	7	33.7/19.4
SCS-3-220	220	1/3	8	36.4/21.0
SCS-3-240	240	1/3	9	37.5/21.7
SCS-5-208	208	1/3	11.5	55.3/32.0
SCS-5-220	220	1/3	13	59.1/34.1
SCS-5-240	240	1/3	15	62.5/36.1

Notice!

Different types of steamer have different electrical parameters. For details, see the device nameplate.

Danger!

To avoid electric shocks, the steamer must be fully grounded. For details, see local standards and documents

2.6 Power supply installation

1. Power cord specifications: the electrician qualified person chooses the suitable cable according to the current specifications of the equipment used.
2. Circuit breaker (European Class C standard)
3. Leakage protector

It is highly recommended to install a leakage protector, and the decoupling current of the leakage protector cannot be less than 30 mA.

4. Power cable connection (Note: the device does not have power cables)

As shown in the picture (figure 1), the power cord connects the device to the automatic circuit breaker first.

As shown in the picture (figure 2), fix the power cable and connect the terminal

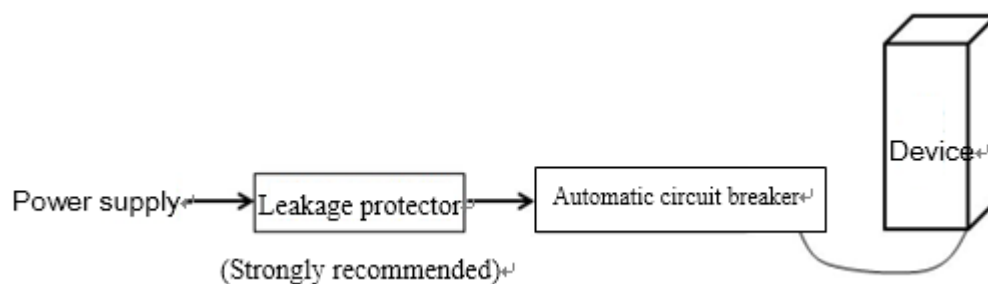

(figure 1)

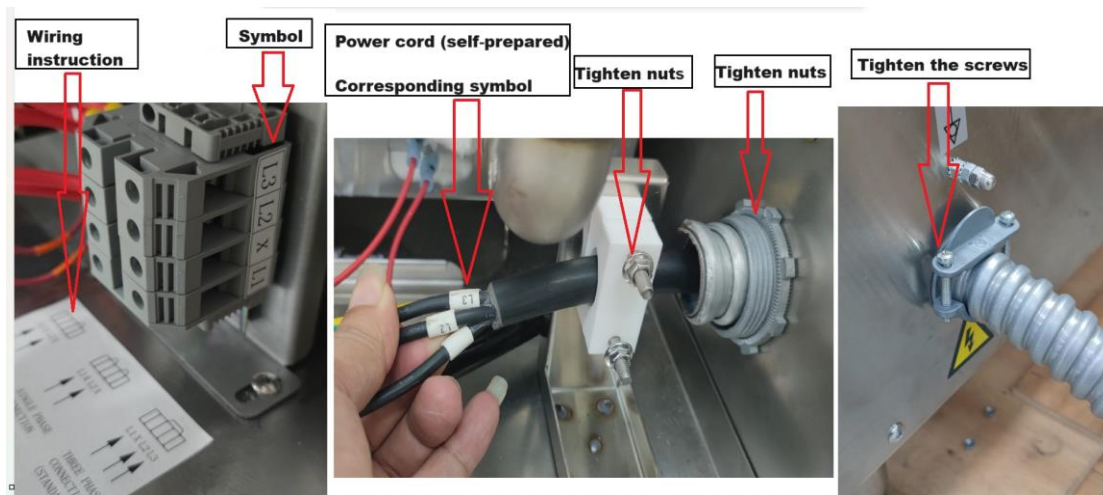

(figure 2)

Consult a qualified electrician if doubt exists on electric connection.

**Warning!**

When connecting the power cord, make sure the connection of each power core is firm and locked tightly. Even if the power cord is acted upon by external force, the connecting terminals will not be loosened due to external force, otherwise it may cause danger. The power cord should be an oil-resistant sheathed cable, not lighter than ordinary neoprene or other equivalent synthetic rubber sheathed cords (YZW). If the power cord is damaged, it must be replaced with an equivalent power cord

**Warning!**

If the power supply is outdoors, please pay attention to the waterproof and dustproof protection measures of the power supply

**Warning!**

In order to avoid the danger caused by the fraying of the power cord, the protective coil must be installed at the outlet of the power cord of the equipment and the hole through which the power cord passes.

**Danger!**

This product must be grounded, or it may cause electric shock or even death. The electrical wiring of the equipment must be connected to a separate power supply by a qualified electrical technician. Each device must be equipped with a dual-circuit insulated switch with appropriate rated capacity and a contact separation distance over 3mm

**Warning!**

When making a ground connection, complete measures must be taken to ensure that the power cord is connected to the ground terminal when subjected to external forces

**Equipotential bonding**

The back of the appliance has an equipotential earth connection for separate earth bonding (GND).

**Caution!**

When the length of the power cord is not enough, please REPLACE with a new power cord with sufficient length. DO NOT CONNECT TWO POWER CORDS TOGETHER FOR EXTENSION

2.7 Water supply connection

1. This equipment has no automatic water inlet, and the water outlet is 1/2 ". Before cooking, it needs to manually add water to the water tank locating at the bottom of the chamber to just below the maximum water level;
2. Connect the drain outlet of the equipment with 1/2 "water pipe, and the other end is discharged into the drain outlet. The drain outlet must be lower than the equipment drain

outlet.

3. Please confirm that all the above connections are watertight.

WARNING The main water supply should be tested for the level of hardness before it is connected to the Steamer. The mains water supply should have a hardness level of below 50MG/L(CaCO3). Anything above this value should be treated with a suitable water softener. Any damage done to the Steamer caused by hard or dirty water will render any warranty invalid. Hard or dirty water must be treated before being connected to the Steamer.

2.8 Dimension

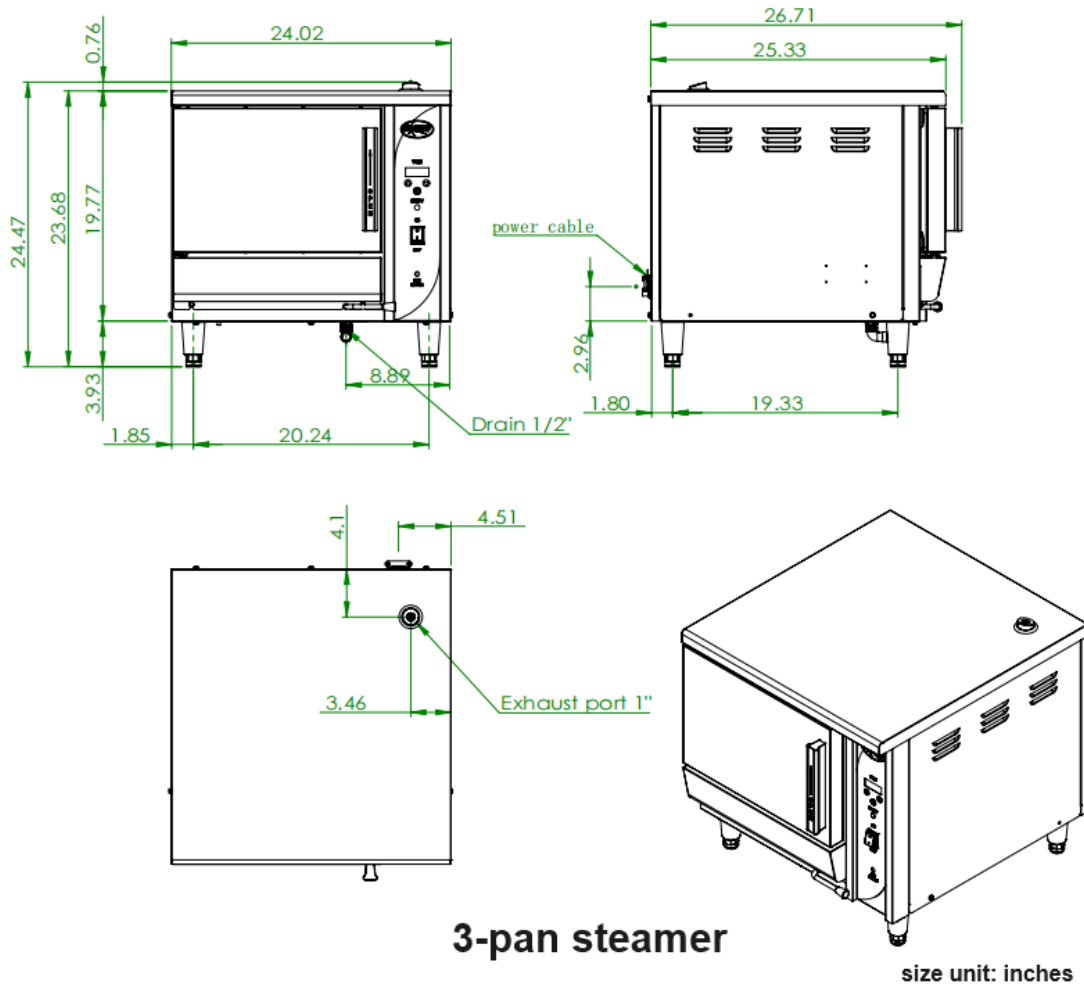

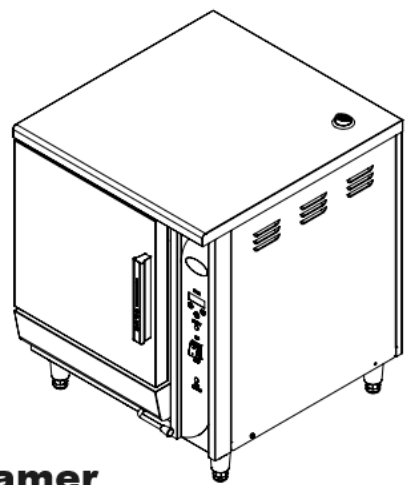
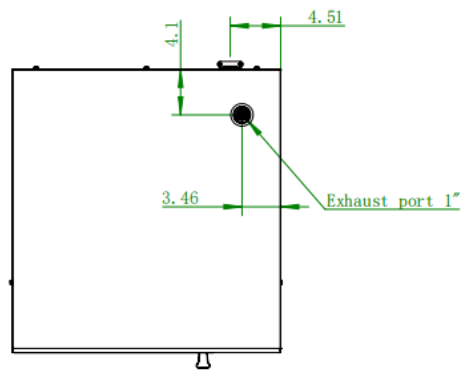
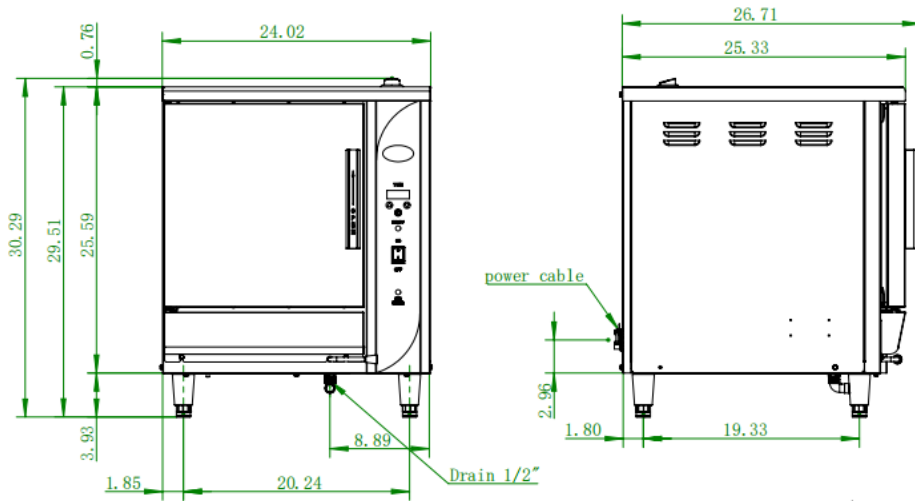

5-pan steamer

size unit: inches

2.9 Pan sizes

PAN CAPACITIES

M O D E L	Pan Depth	Inches	1	2.5	4	6
		mm	25	64	102	152
SCS-3-208	Total quantity of Pans		5	3	2	1
SCS-3-220						
SCS-3-240						
SCS-5-208	Total quantity of Pans		10	5	3	2
SCS-5-220						
SCS-5-240						

3. Instruction

3.1 Position and function of the controller

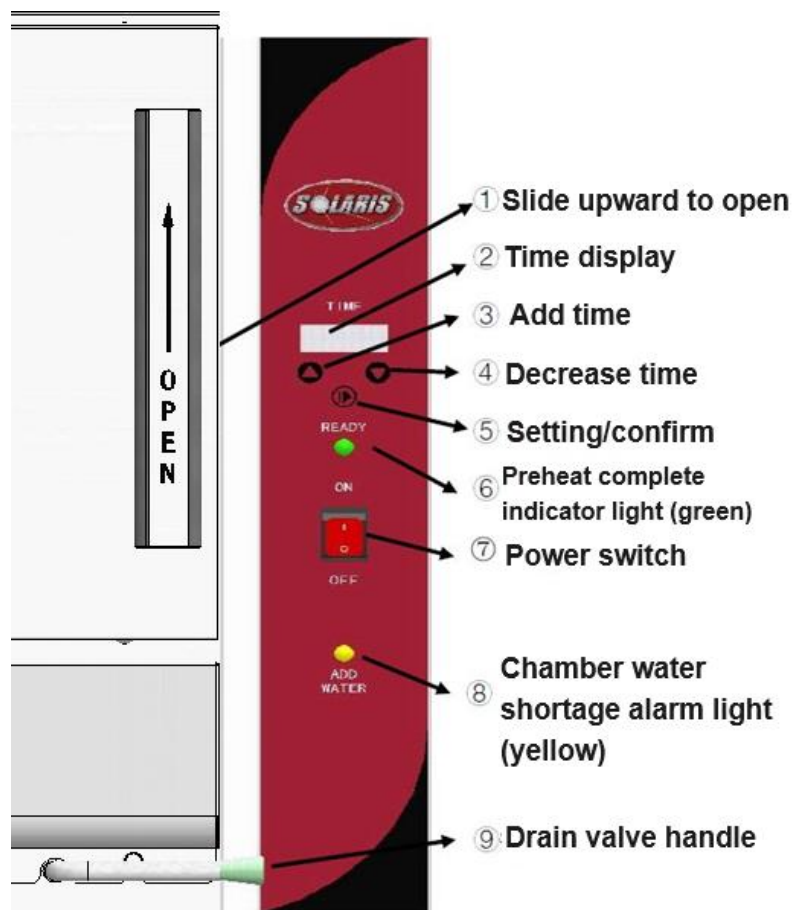

3.2 Description

3.2.1 Adding water manually

Take out the partition of the chamber water tank, manually add water to the chamber, until reach to the "WATER LEVEL"; and then put the partition back in place;

3.2.2 Preheat

Press the power switch to "ON", the steamer is powered on, and it starts to work. About 6 minutes later, there is obvious steam discharge from the vent pipe. The green indicator is on, and the steamer is "Ready".

3.2.3 Steam

After the preheating indicator lights up for the first time, press "▲" or "▼" to adjust the steaming time to the required time (press "▲" or "▼", the time will

increase or decrease by 1 second; press "▲" or "▼" longer, the time will increase or decrease by 10 seconds), press "▶" for confirmation, and press "▶" again to start counting down according to the set time; When the display time countdown changes to "00:00", the buzzer inside the chamber will sound indicating cooking procedure completed; Press and hold "▶" to reset to the original setting time. (The time setting range is "00:00" - "60:00").

During the steaming process, if the door is opened, the heating element stops heating. After the door is closed, the heating element works again. If you need to time again according to the preset value, you can press and hold "▶", timer will be reset to preset value.

Caution!

If the power switch is not turned off in time after cooking, the heating plate will continue to work when the door is closed, it will lead to water shortage in the water tank of chamber, result in dry burning, the yellow indicator light will be on, and the buzzer will sound. Please fill the water tank with cold water to the safe water level in time, or directly turn off the power switch!

3.2.5 Drainage

In the shutdown state, open the door, and after the chamber water tank cools down, pull down the drain handle. Drain the water in the tank of the chamber, and then reset the handle of the drain valve;

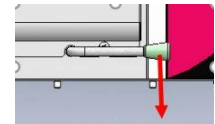

3.2.6 Cleaning of chamber water tank

Open the steamer door after the equipment is used every day. After the water in the water tank is cooled, clean the water tank with neutral cleaning agent and keep the drainage pipe smooth. After cleaning, close the drain valve.

4. Cleaning and maintenance

Warning!

Before any cleaning, maintenance or repair of the steamer, please perform the following steps:

1. Turn off steamer and wait for it to cool down. Do not clean, maintain or repair the steamer before it is cooled down.
2. Turn off the circuit breaker on the power supply of the steamer, or disconnect the power connection of the steamer.

When the cleaning or maintenance of the steamer is completed,

1. If the steamer has moved during cleaning and maintenance, please move it back to its original position.
2. Reconnect the power supply.
3. Turn on the circuit breaker on the power supply of the steamer.
4. Switch on the Steamer.

Warning!

The running parts or electrical parts in the steamer may cause harm to people. Before cleaning, reinstalling or repairing the steamer, please turn off the air switch on the power supply and disconnect the power supply. Never attempt to disassemble or clean the steamer before it works or other circuit switches are closed.

Caution!

Do not use a water jet or pressure steam when cleaning the steamer. Do not use excessive water to clean the outside of the steamer. Do not use a corrosive or caustic cleaning agent on the surfaces of the steamer. Do not use a wire brush or pad to clean the surfaces of the steamer.

Caution!

Any repair and replacement of the steamer must be carried out by the maintenance provider authorized by manufacturer. We also strongly recommend that you have your steamer serviced every three and six months by an authorized steamer service provider.

4.1 Cleaning and maintenance steps

Step	Operation
1	Please check whether the steamer has cooled down and the power supply has been turned off.
2	Clean the outer surface of the steamer with soft cloth and non-corrosive detergent.

3	Remove and clean the tray support racks.
---	--

5. Trouble shooting

Although we have made every effort to ensure the continuous and efficient operation of the steamer, malfunction is inevitable. Before making a malfunction service call, check with the following table. Some problems can be easily eliminated.

Problem	Action
The yellow water supplement reminder indicator light is on, and the buzzer sounds	1. Fill the chamber water tank with water in time
When the switch is turned on, the switch indicator does not light on, the digital display board is not powered on, and it does not display	1. The switch is damaged. Replace the switch 2. If the fuse is blown, replace the fuse; 3. Check whether the main power circuit is normal
The preheating indicator (green) is always off	1. There is no temperature in the chamber, check whether the heating element if it works 2. The green indicator light is damaged, replace the indicator light 3. The temperature controller on the side wall of the inner chamber is damaged. Replace the temperature controller

Discard device correctly



The correct product disposal method (recycling of electronic and electrical products) in the European Union and other European countries is the waste separation and recycling system. If the symbol on the left side appears on the product or description, it means that the product cannot be disposed of with other household waste at the end of its service life. In order to prevent uncontrolled garbage disposal that may cause harm to the environment or personal safety, please separate such garbage from other garbage for recycling and promote the recycling of resources. Household users can consult the retailer selling this product or the relevant local government department for environmentally sound recycling of such products. Commercial users need to consult the supplier and check the relevant terms of the purchase contract, this product can not be disposed of with other commercial waste.