



ELECTRIC COUNTER CONVECTION STEAMER



SCS-3 Shown

SPECIFICATIONS:

Solaris Model SCS-3 & SCS-5 is a single compartment counter-top electric, water connectionless steamer. ETL certified to the UL 197 and NSF-4 standard. Stainless steel exterior, with a cooking chamber of one piece all welded 304 stainless-steel with coved corners. The door has a removable inner liner of stainless steel with full perimeter gasket seal, an outer liner of one piece all welded stainless steel, and a slide lock and seal mechanism.

Efficient steam generation require no water or drain connections. Steam generated a Zero (0) p.s.i. by tubular elements embedded in approximately 1" thick cast aluminum for heat production, sealed at the bottom with thermal compound for even heat distribution.

The control housing is constructed of stainless steel with full access removable of top and side panels for serviceability. The controls include illuminated two-way power switch (On / Off), pilot indicator ready light, pilot lamp to add water light, a "60" minute digital timer which produces an audible sound at the end of the cooking cycle. The steamer is provided with removable stainless-steel pan supports. Also provide are 4" Stainless-Steel non-slip legs. Phase is field convertible.

Effective Chamber Size:

SCS-3: 13.90" X 20.98" X 11.30"
SCS-5: 13.90" X 20.98" X 17.13"

Warranty: Entrée's exclusive parts and labor FUSS warranty takes effect at time of purchase for 1 year.

Model	Compartment Pan Capacity			
	Pan Depth			
	1"	2.5"	4"	6"
SCS-3	5	3	2	1
SCS-5	10	5	3	2

Function/Operation is by:

Electrically heated, boiler free steam generation rated at:

- ❖ SCS-3-208 - 7 kW
- ❖ SCS-5-208 - 11.5 kW
- ❖ SCS-3-240 - 9 kW
- ❖ SCS-5-240 - 15 kW

The steam generation will be equipped for operation on:

- 208 VAC/3 Phase, 50/60 Hz
- 240 VAC/3 Phase, 50/60 Hz

***UNIT SHALL BE FIELD CONVERTIBLE TO SINGEL PHASE**

STANDARD FEATURES:

- 201 Series Stainless Steel Exterior
- 304 Series Stainless Steel interior with coved corners
- Heavy duty stainless steel door with removeable liner
- Full perimeter door gasket
- Positive slide lock door mechanism with spring release door
- Ready indicator light
- Cooking indicator light
- Add water indicator light with audible alarm
- Digital timer with end of cycle audible alarm
- 4" adjustable non-skid legs
- Removable stainless steel pan supports
- Removable steam diffuser plate to prevent debris from falling into reservoir
- Selectable timed or constant steam cooking mode

**This appliance is for commercial indoor use only.
Not suitable for installation in a non-commercial or residential applications.



Intertek



Intertek



DETAILS AND DIMENSIONS

WATER QUALITY STATEMENT

Water quality is the major factor affecting the performance of your appliance. If you are unsure of water quality, consult a local water treatment specialist and have the water analyzed. Your water supply must be within these general guidelines:

Total dissolved solids	Less than 60 PPM
Total alkalinity	Less than 20 PPM
Silica	Less than 13 PPM
Chlorine	Less than 1.5 PPM
pH Factor	7.0-8.5

Water which fails to meet these standards should be treated by installation of water conditioner.

FAILURE OR MALFUNCTION OF THIS APPLIANCE DUE TO POOR WATER QUALITY IS NOT COVERED UNDER WARRANTY.

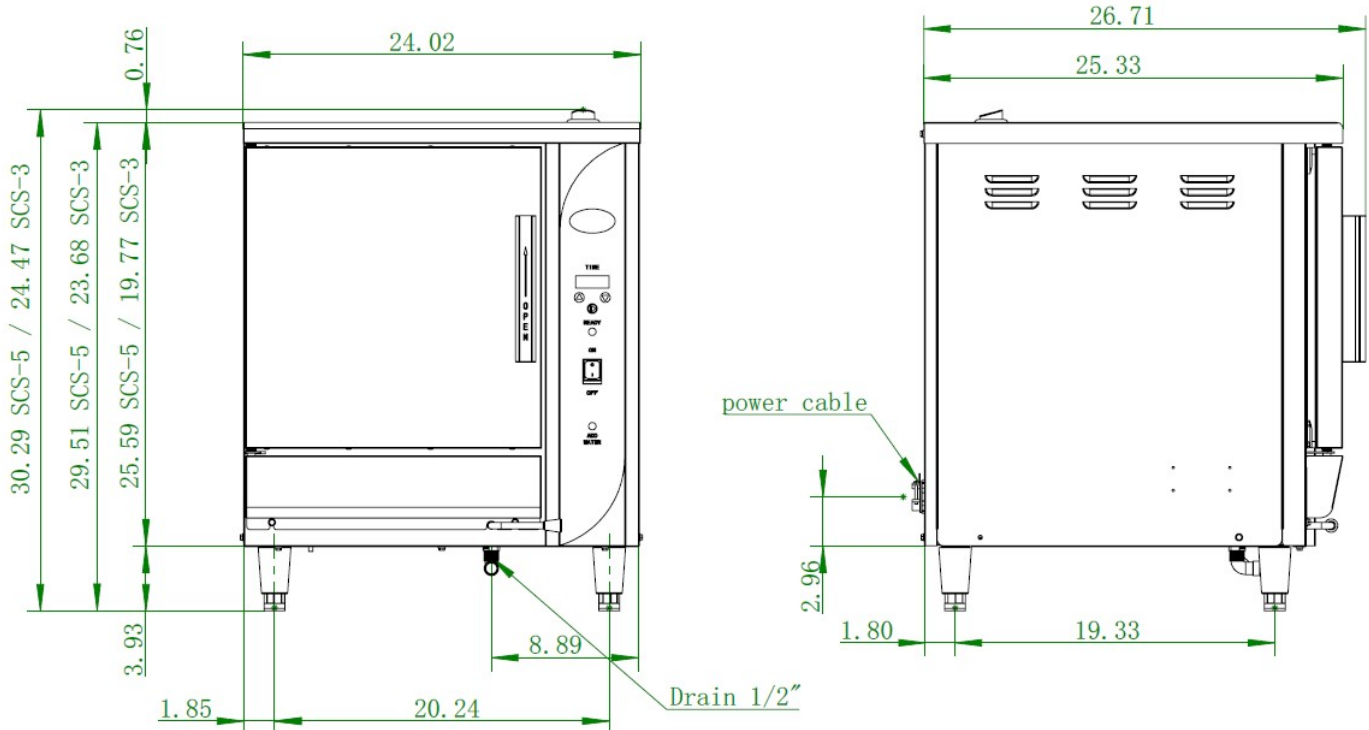

NOTE: Electrical Connection to Electrical Box:
1 1/4" Conduit Connection w/9' of 1" Dia. BX Tube.
Drain: 1/2" NPT

CLEARANCE:
REAR: 2.4", Right or Left Side: 2.4"

If drain line is connected to the steamer, the material must be suitable for 212°F water. If no drain plumbing is connected, a suitable catch pan must be used. It is the owner's responsibility to comply with all local codes for installation.

*Unit shall be field convertible to single phase.

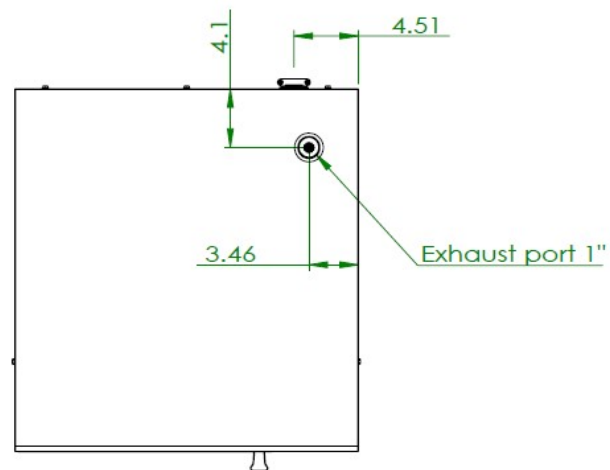

Model	Voltage	kW	Amps		Exterior Dimensions			Net Weight lbs.	Shipping Dimensions			Shipping Weight lbs.
			Single	Three	Width	Height	Depth		Width	Height	Depth	
SCS-3-208	208VAC	7	33.7	19.4	24.2"	24.47"	26.71"	142	29.3	26.2	27.2	172
SCS-3-240	240VAC	9	37.5	21.7	24.2"	24.47"	26.71"	142	29.3	26.2	27.2	172
SCS-5-208	208VAC	11.5	55.3	32.0	24.2"	30.29	26.71"	161	29.3	32.0	27.2	195
SCS-5-240	240VAC	15	62.5	36.1	24.2"	30.29	26.71"	161	29.3	32.0	27.2	195