

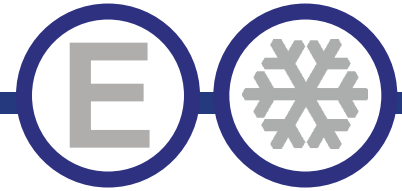

NEW IMPROVED DESIGN

Series "B"



ICE CREAM DIPPING CABINETS



EDC18X



EDC26X
EDC35X

Model	Size
EDC18X	47" Unit
EDC26X	67" Unit
EDC35X	88" Unit

STANDARD FEATURES

- **New improved design.** Cold wall lines run around the perimeter of the cabinet allowing for more uniform temperature and dependability!
- Stainless steel top, with glass viewing window. White aluminum interior and exterior.
- Refrigeration system keeps ice cream at temperatures between -15°F and -10°F
- Transparent lids hinged with a full length handle.
- Ice Cream Tub Holders with night covers. (Round container lids are not included.)
- Electronic control system makes it easy to adjust temperature set point and defrost frequency.
- Pre-installed 3" swivel casters with brakes.
- Easy to access condenser coil for cleaning and service.
- Uses R290 refrigerant, which is eco-friendly and more efficient.
- Interior efficient LED lighting
- Warranty: One year parts & labor warranty, and additional two years on compressor.

*Not suitable for installation in a non-commercial or residential applications.

Items	Description	Items	Description
Top	Stainless steel	Temperature control	Solid state thermostat/Digital display
Doors	Transparent hinged lid	Approvals	ETL LISTED
External back	White Aluminum	Refrigerating system	Capillary tube
Cabinet interior	White Aluminum	Refrigerant	R290
Interior floor	White Aluminum	Temperature range	-15°F to -10°F
Insulation	Polyurethane (CFC free)	Evaporator	Powder coated aluminum/copper
		Condensing unit	Bottom mounted

CONFORMS TO NSF/ANSI STD 7

REFRIGERATION





DETAILS AND DIMENSIONS

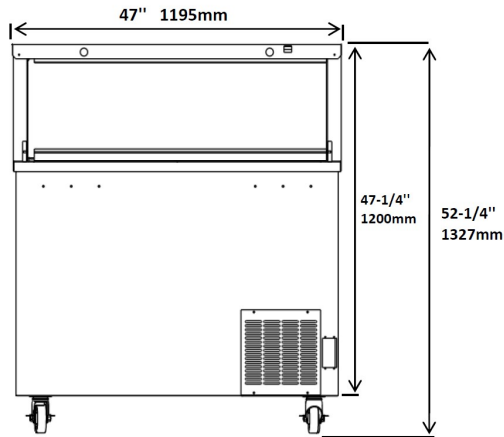

EDC26X

SIDE VIEW ALL

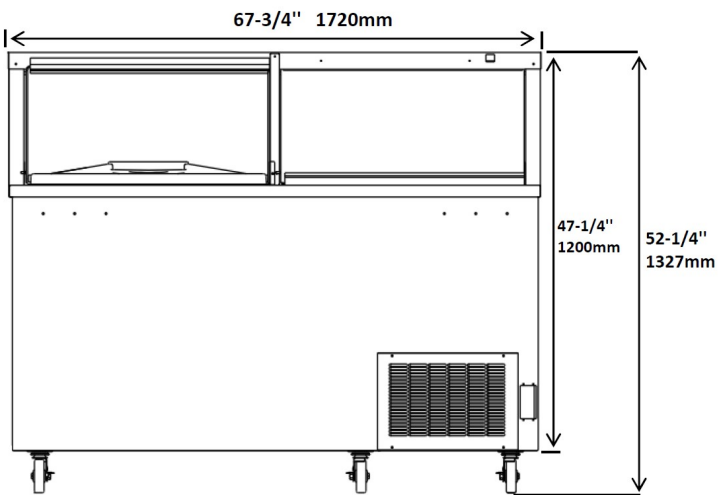
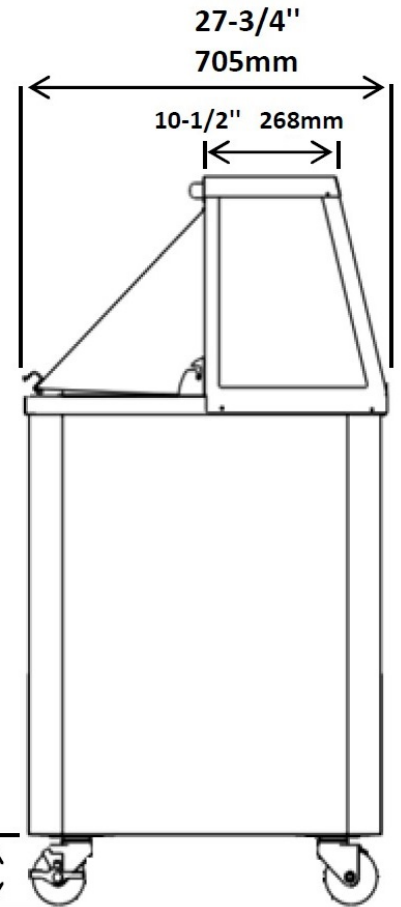

EDC26X

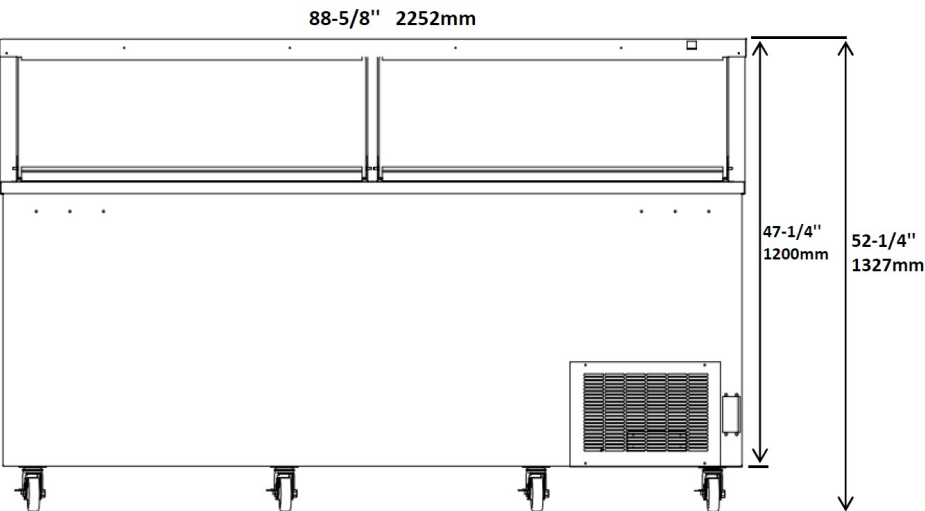

EDC35X

Model	LIDS	RACKS	CAPACITY (3 GAL.)		Cabinet Dim (inches)			HP	Voltage	Amps	NEMA Plug	Cord Length	Ship Weight
			Display	Storage	W	D	H						
EDC18X	1	4	8	4	47	27.75	52.25	1/4	115/60/1	5.16	5-15P	10	345
EDC26X	2	6	12	8	67.75	27.75	52.25	1/2	115/60/1	5.64	5-15P	10	431
EDC35X	2	8	16	12	88.625	27.75	52.25	1	115/60/1	6.00	5-15P	10	528