

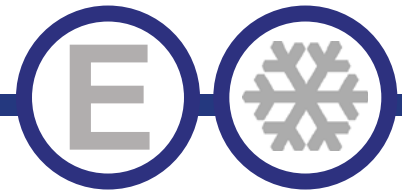

Series "B"



STANDARD MERCHANDISER REFRIGERATOR

EGM48X



EGMSDR54X



Model	Doors
EGM48X	2 SWING
EGMSDR54X	2 SLIDING
EGMDR78X	3 SWING

STANDARD FEATURES

- Exterior: Coated steel. Black or white or Stainless steel finish available.
- Interior: Attractive aluminum liner with stainless steel floor.
- Refrigeration system maintains temperatures between 33°F and 41°F .
- Self-Closing double pane glass door with positive seal.
- Shelves: Adjustable heavy-duty PVC coated shelves.
- Electronic control system makes it easy to adjust temperature set point and defrost frequency.
- Easy to access condenser coil for cleaning and service.
- Uses R290 refrigerant, which is eco-friendly and more efficient.
- Interior efficient LED lighting.
- 3" Swivel Casters are pre-installed
- Warranty: Two year parts & labor warranty, and additional three years on compressor.



EGMDR78X

*Not suitable for installation in a non-commercial or residential applications.

Items	Description	Items	Description
Front, top & sides	Coated steel	Temperature control	Solid state thermostat/Digital display
Doors	Double Pane Glass Swing	Approvals	ETL Listed
External back	Coated steel	Refrigerating system	Capillary tube
Cabinet interior	Aluminum	Refrigerant	R290
Interior floor	Stainless steel	Temperature range	33°F to 41°F
Insulation	Polyurethane (CFC free)	Evaporator	Powder coated aluminum/copper
Shelves	Heavy duty, PVC coating	Condensing unit	Bottom mounted

CONFORMS TO NSF/ANSI STD 7

REFRIGERATION

EGM48X

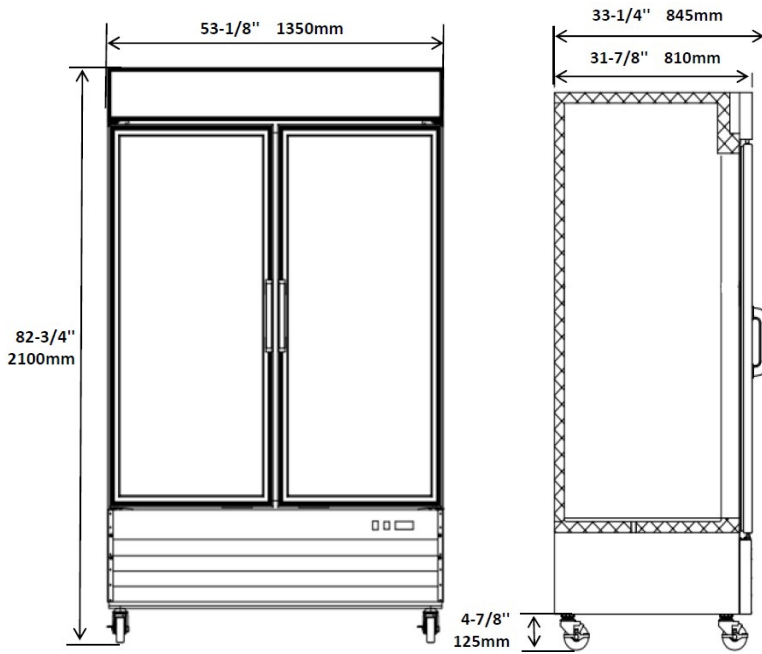

EGM48X Top View

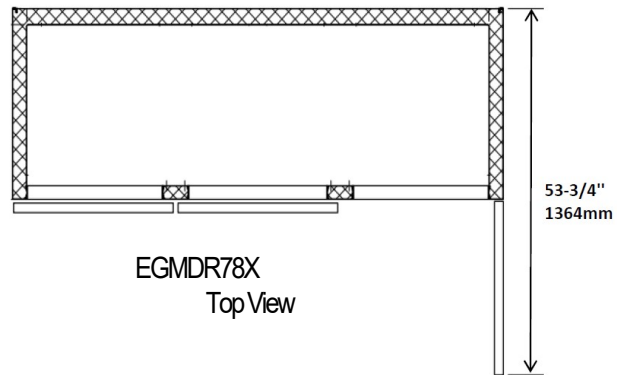
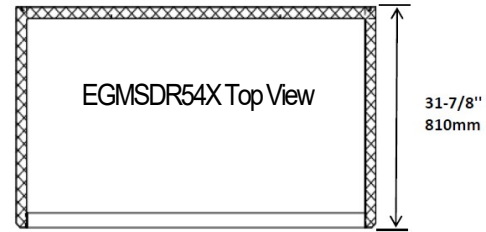
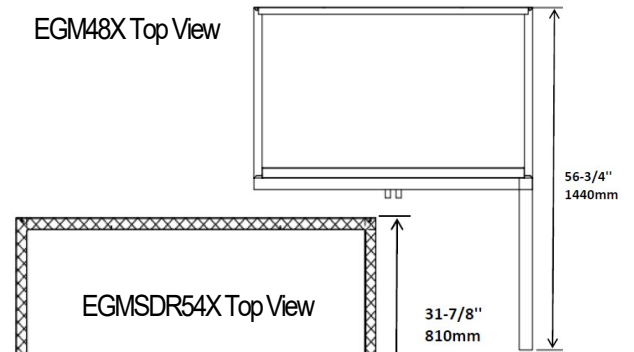

EGMSDR54X Front & Side View

Front and Side View

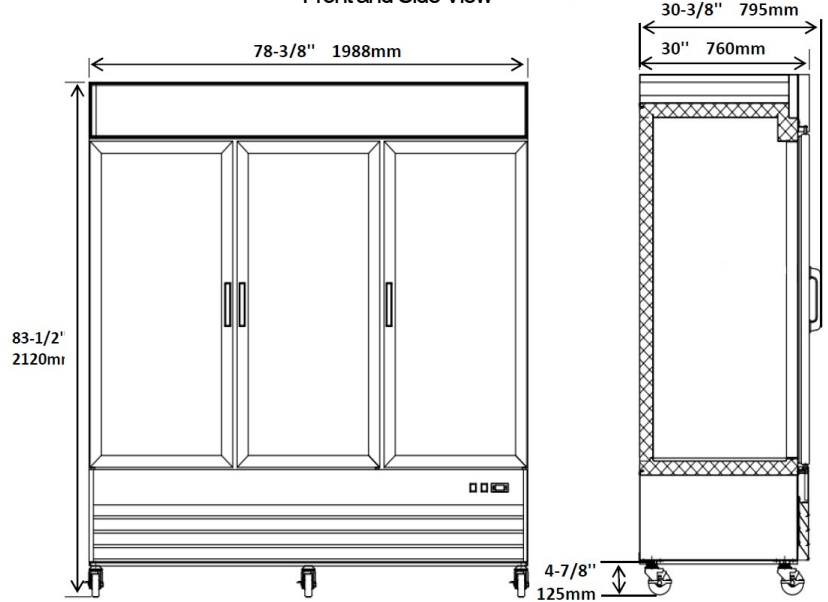
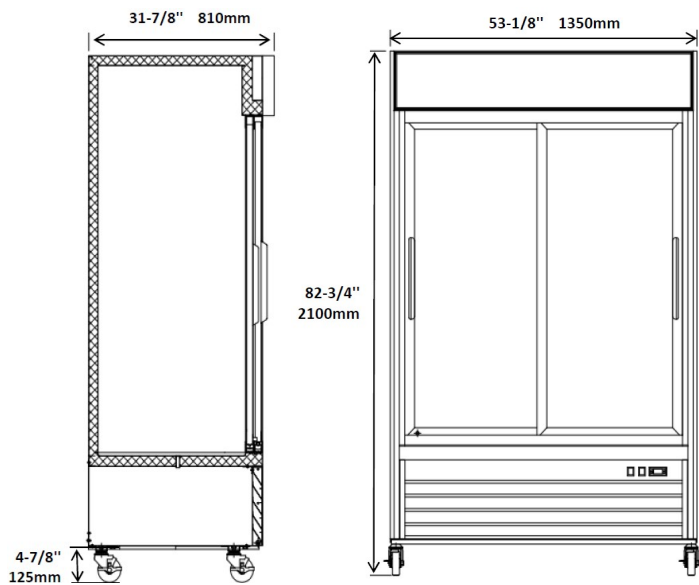

Model	Doors	Shelves	Cabinet Dim (inches)			HP	Voltage	Amps	NEMA Plug	Cord Length	Crated Weight
			W	D	H						
EGM48X	2	8	53.125	31.875	82.75	1/4	115/60/1	4.5	5-15P	10	495
EGMSDR54X	2	8	53.125	31.875	82.75	1/4	115/60/1	4.5	5-15P	10	495
EGMDR78X	3	12	78.375	30.0	83.5	3/4	115/60/1	10.7	5-15P	10	700