

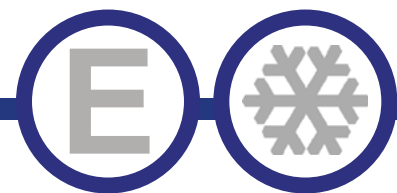

Series "B"



MERCHANDISER FREEZER

EGMF26X



EGMF27X



Model	Doors
EGMF26X	1
EGMF27X	1

STANDARD FEATURES

- Exterior: Coated steel. Black or white or Stainless steel finish available.
- Interior: Attractive aluminum liner with stainless steel floor.
- Refrigeration system maintains temperatures between -8°F and 0°F .
- Self-Closing double pane glass door with positive seal.
- Shelves: Adjustable heavy-duty PVC coated shelves.
- Electronic control system makes it easy to adjust temperature set point and defrost frequency.
- Easy to access condenser coil for cleaning and service.
- Uses R290 refrigerant, which is eco-friendly and more efficient.
- Interior efficient LED lighting.
- 3" Swivel Casters are pre-installed
- Warranty: Two year parts & labor warranty, and additional three years on compressor.

*Not suitable for installation in a non-commercial or residential applications.

Items	Description	Items	Description
Front, top & sides	Coated steel	Temperature control	Solid state thermostat/Digital display
Doors	Double Pane Glass Swing	Approvals	ETL Listed
External back	Coated steel	Refrigerating system	Capillary tube
Cabinet interior	Aluminum	Refrigerant	R290
Interior floor	Stainless steel	Temperature range	-8°F to 0°F
Insulation	Polyurethane (CFC free)	Evaporator	Powder coated aluminum/copper
Shelves	Heavy duty, PVC coating	Condensing unit	Bottom mounted

CONFORMS TO NSF/ANSI STD 7

REFRIGERATION





DETAILS AND DIMENSIONS

EGMF26X

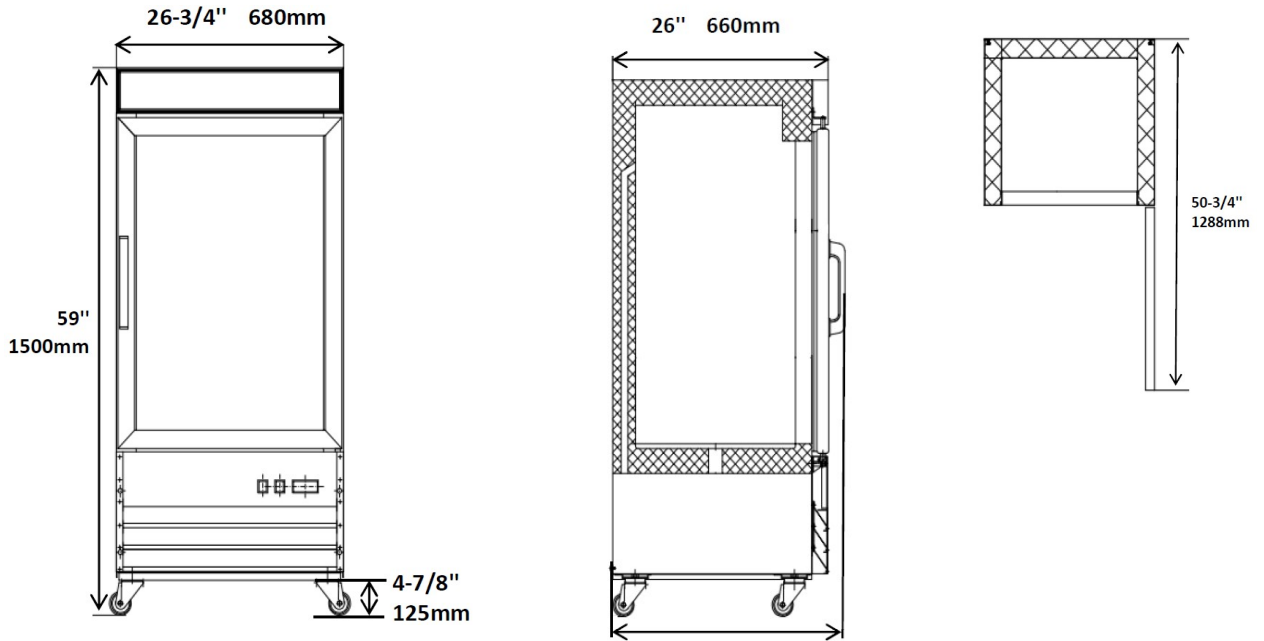

EGMF27X

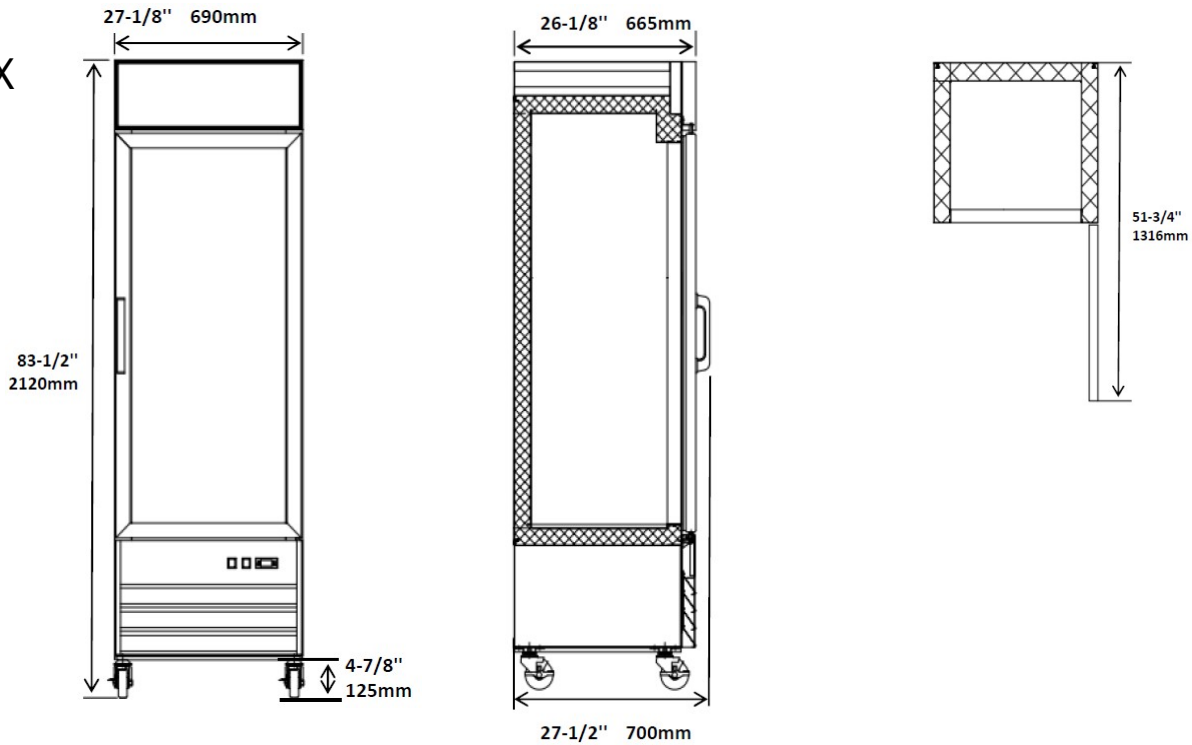

Model	Doors	Shelves	Cabinet Dim (inches)			HP	Voltage	Amps	NEMA Plug	Cord Length	Crated Weight
			W	D	H						
EGMF26X	1	3	26.75	26	59	1/4	115/60/1	4.2	5-15P	10	297
EGMF27X	1	4	27.125	26.125	82.5	3/4	115/60/1	8.8	5-15P	10	374