

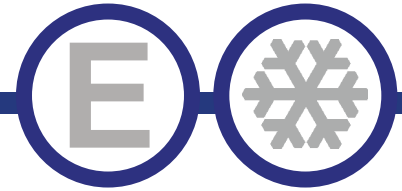

# Series "B"



## GLASS FROSTERS



EGF27X



EGF49X

Model	Size
EGF27X	26" Unit
EGF49X	49" Unit

### STANDARD FEATURES

- Durable stainless steel top, coated aluminum interior
- Exterior construction is attractive corrosion resistant vinyl on steel in black finish
- Refrigeration system keeps the glasses at safe temperatures between -5°F to 2°F
- Electronic control system makes it easy to adjust temperature set point and defrost frequency
- Pre-installed 3" swivel casters with brakes.
- Easy to access condenser coil for cleaning and service
- Uses R290 refrigerant, which is eco-friendly and more efficient
- Adjustable coated-steel dividers included
- Warranty: Two year parts & labor warranty, and additional three years on compressor.

\*Not suitable for installation in a non-commercial or residential applications.

Items	Description	Items	Description
Top	Stainless steel	Temperature control	Solid state thermostat/Digital display
External Front & Sides	Vinyl on Steel in Black Finishe	Approvals	ETL LISTED
External back	Aluminum	Refrigerating system	Capillary tube
Cabinet interior	Coated Aluminum	Refrigerant	R290
Interior floor	Coated Aluminum	Temperature range	-5°F to 2°F
Insulation	Polyurethane (CFC free)	Evaporator	Powder coated aluminum/copper
Dividers	Heavy duty, PVC coating	Condensing unit	Bottom mounted

CONFORMS TO NSF/ANSI STD 7

REFRIGERATION





# DETAILS AND DIMENSIONS

EGF27X

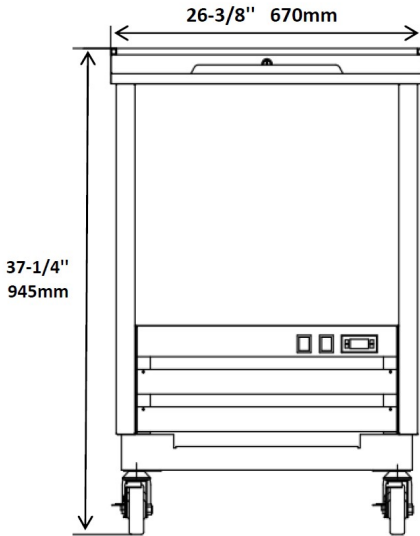

Side View All

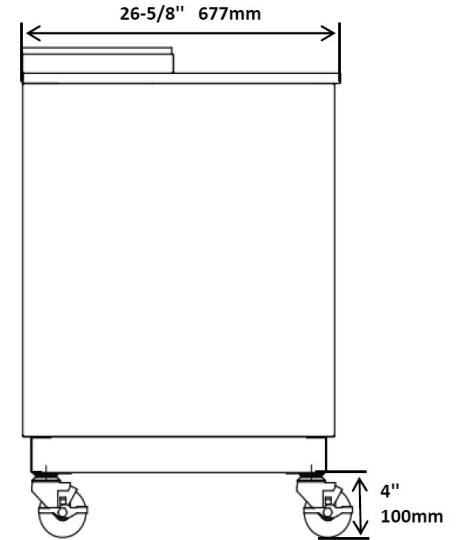

EGF49X

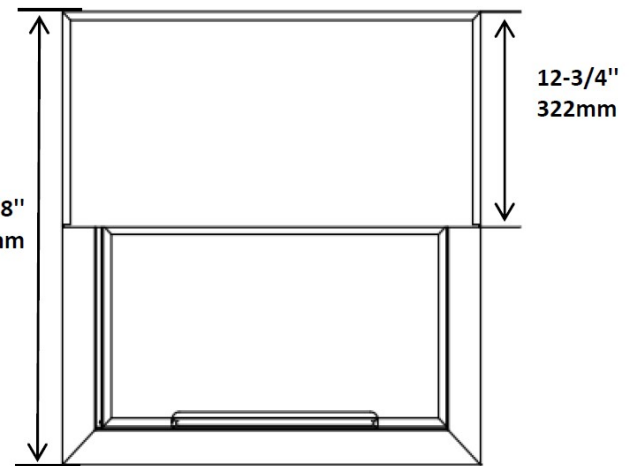
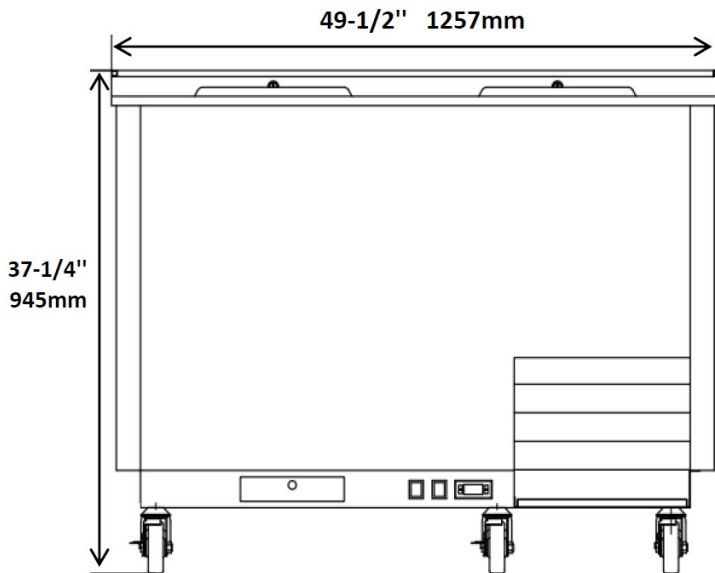

Top View All

EGF49X

Model	Doors	Shelves	Cabinet Dim (inches)			HP	Voltage	Amps	NEMA Plug	Cord Length	Ship Weight
			L	D	H						
EGF27X	1	4	26.625	26.625	37.25	1/5	115/60/1	3.3	5-15P	10	158
EGF49X	2	8	49.50	26.625	37.25	1/4	115/60/1	5.3	5-15P	10	253