

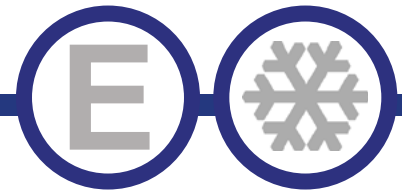

Series "B"



COUNTERTOP MERCHANDISER REFRIGERATOR

Model
ECM5X
ECM7X



ECM5X



ECM7X

STANDARD FEATURES

- Exterior: Coated steel. Black or white or Stainless steel finish available.
- Interior: Attractive aluminum liner with stainless steel floor.
- Refrigeration system maintains temperatures between 33°F to 41°F .
- Swing glass door.
- Shelves: Adjustable heavy-duty PVC coated shelves.
- Electronic control system makes it easy to adjust temperature set point and defrost frequency.
- Easy to access condenser coil for cleaning and service.
- Uses R290 refrigerant, which is eco-friendly and more efficient.
- Interior efficient LED lighting.
- Warranty: One year limited from date of purchase.

*Not suitable for installation in a non-commercial or residential applications.

Items	Description	Items	Description
Front, top & sides	Coated steel	Temperature control	Solid state thermostat/Digital display
Doors	Glass Swing	Approvals	ETL Listed
External back	Coated steel	Refrigerating system	Capillary tube
Cabinet interior	Aluminum	Refrigerant	R290
Interior floor	Stainless steel	Temperature range	33°F to 41°F
Insulation	Polyurethane (CFC free)	Evaporator	Powder coated aluminum/copper
Shelves	Heavy duty, PVC coating	Condensing unit	Bottom mounted

CONFORMS TO NSF/ANSI STD 7

REFRIGERATION



DETAILS AND DIMENSIONS

ECM5X

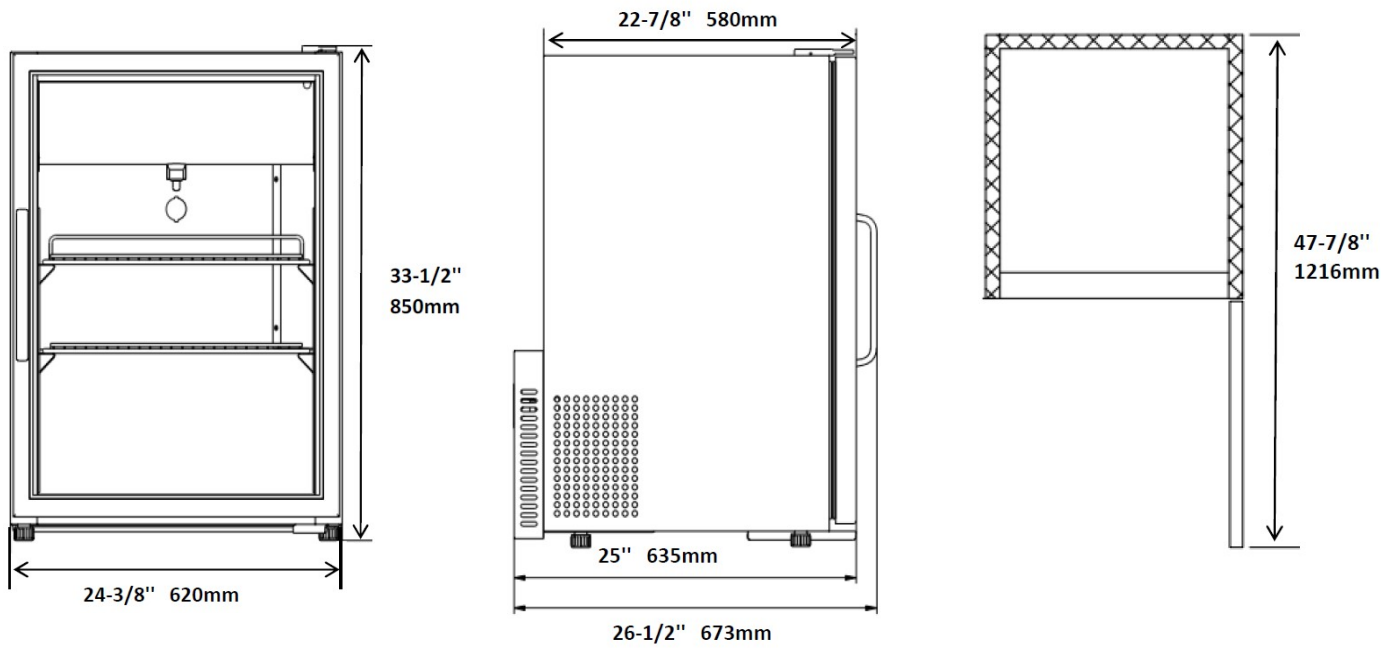

ECM7X

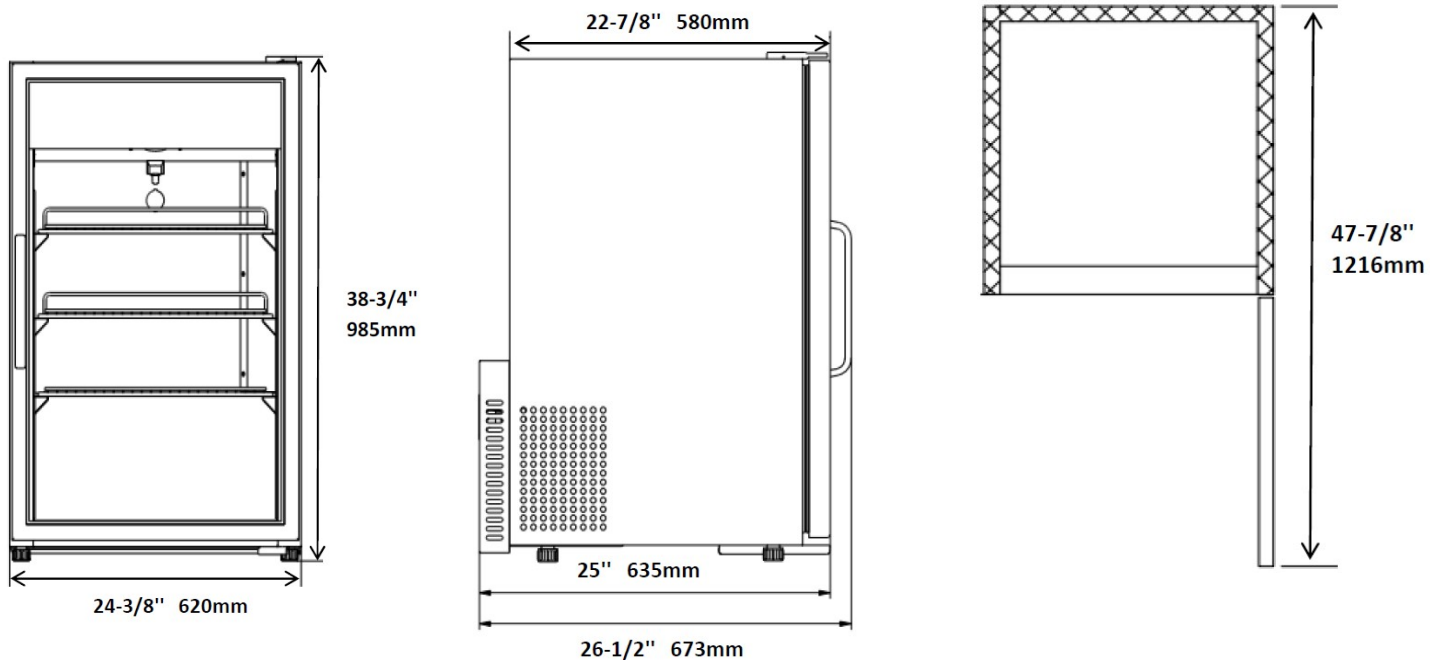

Model	Doors	Shelves	Cabinet Dim (inches)			HP	Voltage	Amps	NEMA Plug	Cord Length	Crated Weight
			L	D	H						
ECM5X	1	2	24.375	25.25	33.25	1/5	115/60/1	1.8	5-15P	10	139
ECM7X	1	3	24.375	25.25	38.625	1/5	115/60/1	2.0	5-15P	10	158