

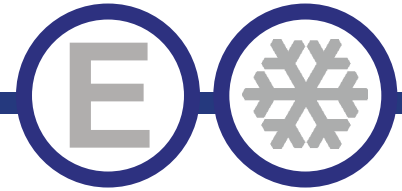

# Series "B"



## REFRIGERATED DELI CASES



Model	Size
EDC36X	36" Unit
EDC47X	48" Unit
EDC64X	64" Unit
EDC79X	82" Unit



### STANDARD FEATURES

- Interior: Aluminum liner with stainless steel floor
- Exterior: Black or White coated Steel. Stainless steel available.
- Rounded corner design inside of the cabinet makes it easy to clean the inside storage room.
- Attractive curved glass and sliding glass doors.
- Refrigeration system keeps meats and deli products at safe temperatures between 33°F and 43°F
- Shelves: Adjustable heavy-duty PVC coated shelves.
- Electronic control system makes it easy to adjust temperature set point and defrost frequency.
- Pre-installed 3" swivel casters with brakes.
- Easy to access condenser coil for cleaning and service.
- Uses R290 refrigerant, which is eco-friendly and more efficient.
- Interior efficient LED lighting.
- Warranty: One year parts & labor warranty, and additional two years on compressor.

\*Not suitable for installation in a non-commercial or residential applications.

Items	Description	Items	Description
Exterior	Coated Steel	Temperature control	Solid state thermostat/Digital display
Cabinet interior	Aluminum Liner	Approvals	ETL LISTED
External back	Coated Steel	Refrigerating system	Capillary tube
Interior floor	Stainless steel	Refrigerant	R290
Insulation	Polyurethane (CFC free)	Temperature range	33°F to 43°F
Shelves	Heavy duty, PVC coating	Evaporator	Powder coated aluminum/copper
		Condensing unit	Bottom mounted

CONFORMS TO NSF/ANSI STD 7

REFRIGERATION





# DETAILS AND DIMENSIONS

EDC36X

EDC36X TOP VIEW

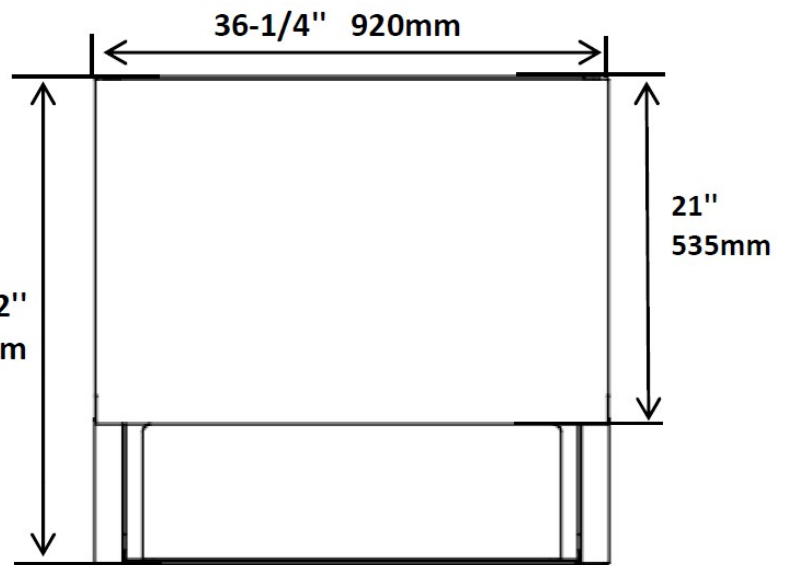
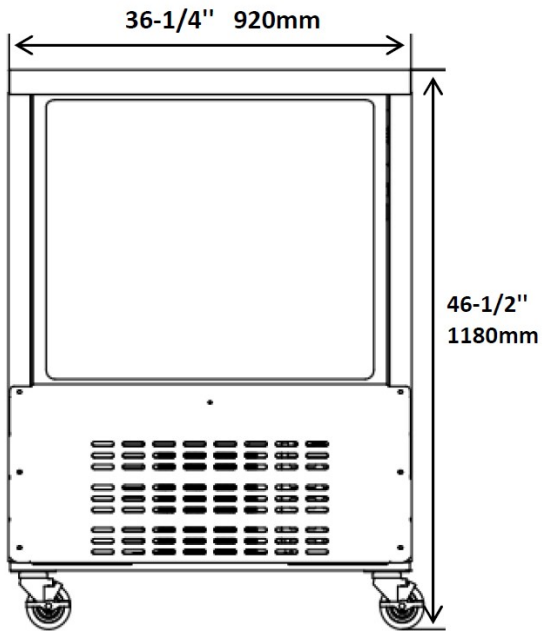

EDC47X

EDC47X TOP VIEW

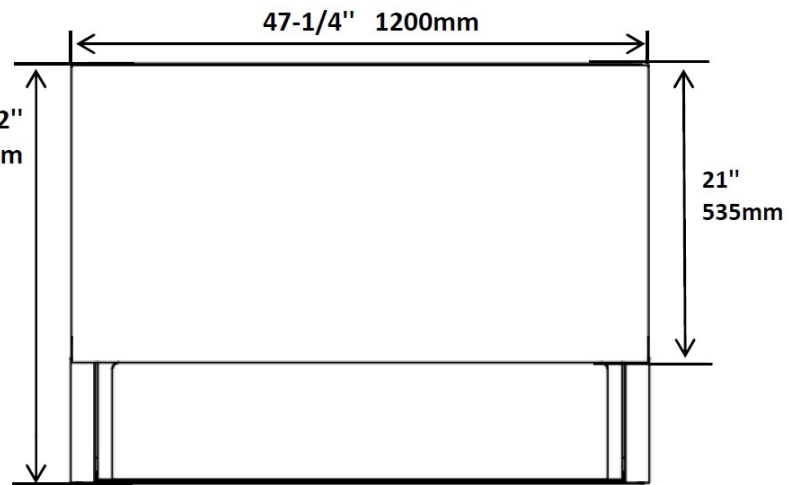
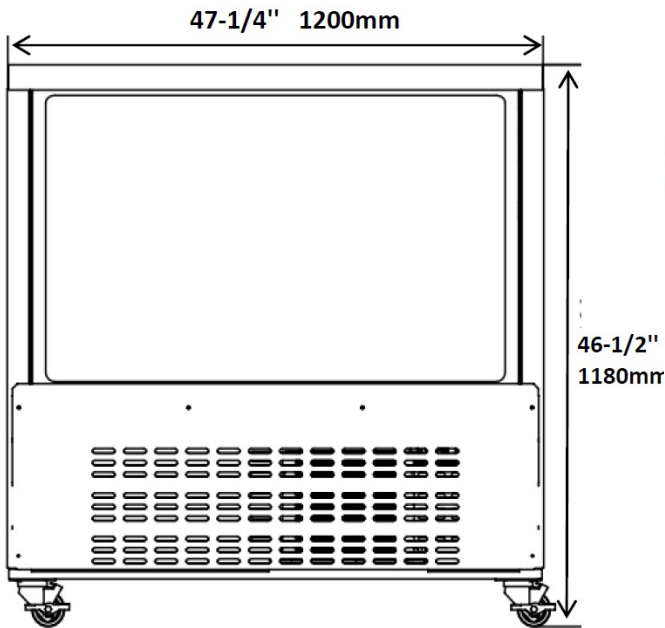

Model	Doors	Shelves	Cabinet Dim (inches)			HP	Voltage	Amps	NEMA Plug	Cord Length	Ship Weight
			L	D	H						
EDC36X	2	4	36	32.5	42.875	1/4	115/60/1	4.68	5-15P	10	297
EDC47X	2	6	48	32.5	42.875	1/4	115/60/1	3.12	5-15P	10	429
EDC64X	3	9	64	32.5	42.875	1/2	115/60/1	7.14	5-15P	10	484
EDC79X	3	9	82	32.5	42.875	3/4	115/60/1	7.14	5-15P	10	638



# DETAILS AND DIMENSIONS

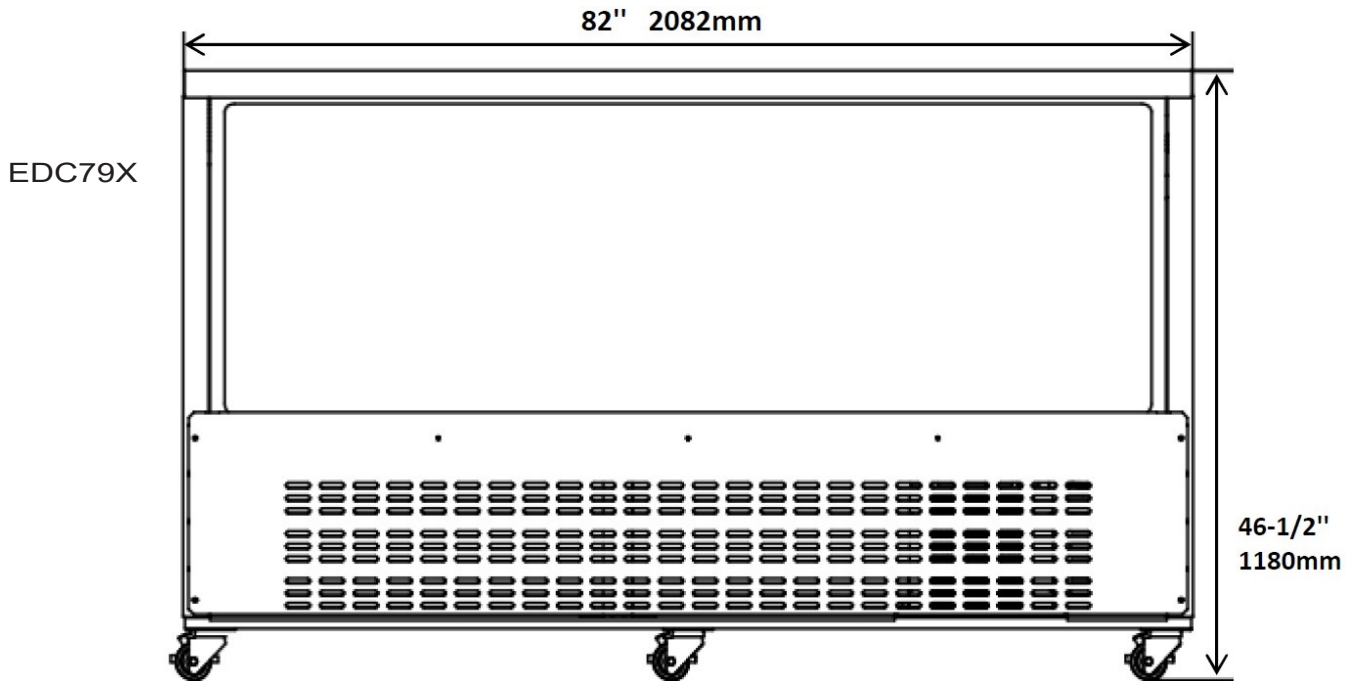
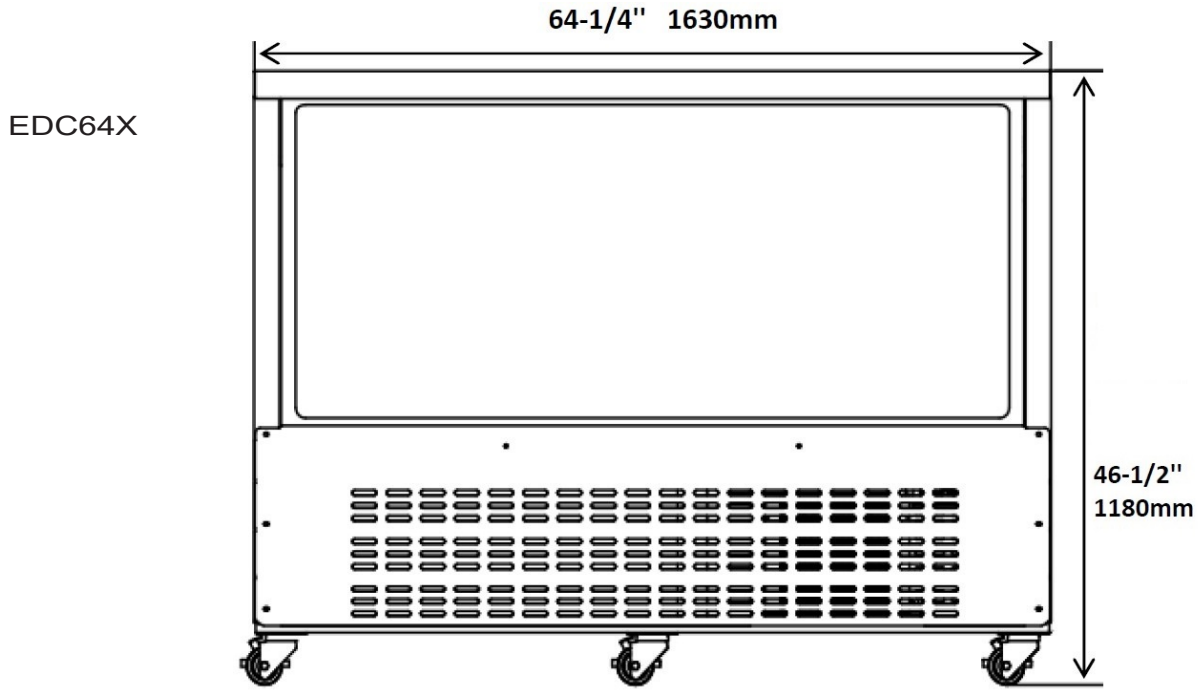

Model	Doors	Shelves	Cabinet Dim (inches)			HP	Voltage	Amps	NEMA Plug	Cord Length	Ship Weight
			L	D	H						
EDC36X	2	4	36	32.5	42.875	1/4	115/60/1	4.68	5-15P	10	297
EDC47X	2	6	48	32.5	42.875	1/4	115/60/1	3.12	5-15P	10	429
EDC64X	3	9	64	32.5	42.875	1/2	115/60/1	7.14	5-15P	10	484
EDC79X	3	9	82	32.5	42.875	3/4	115/60/1	7.14	5-15P	10	638



# DETAILS AND DIMENSIONS

EDC64X TOP VIEW

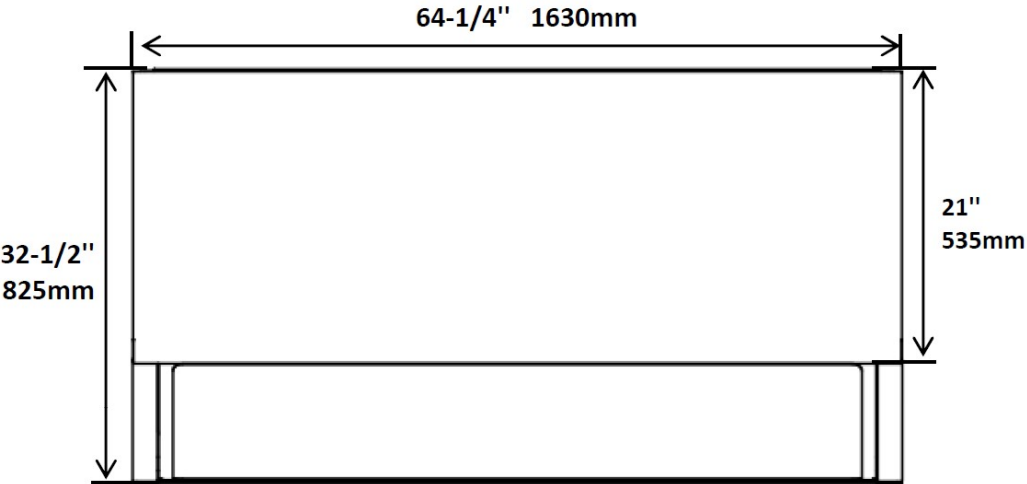

SIDE VIEW ALL

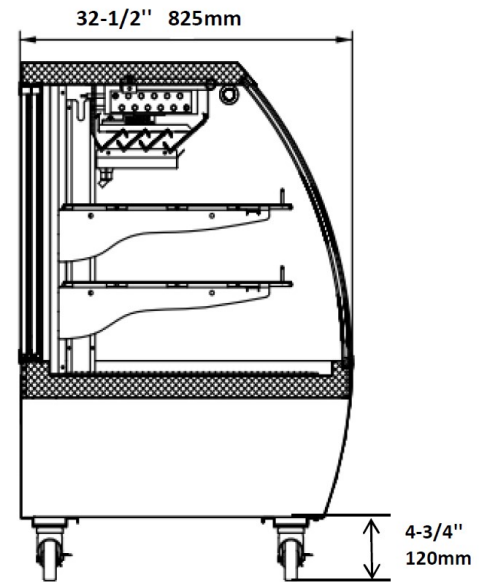

EDC79X TOP VIEW

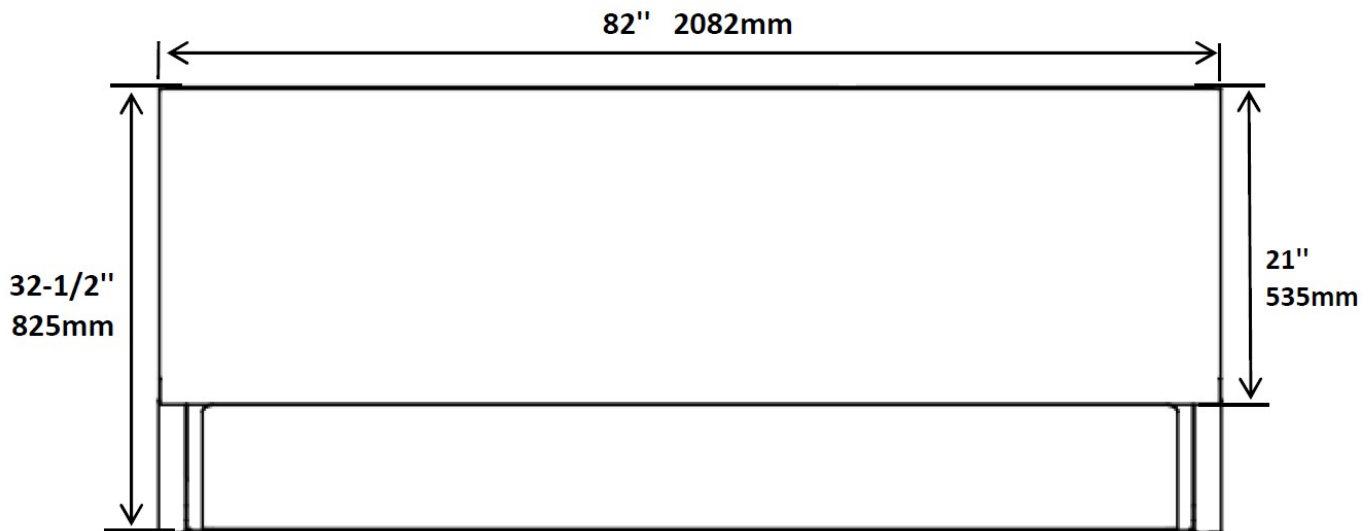

Model	Doors	Shelves	Cabinet Dim (inches)			HP	Voltage	Amps	NEMA Plug	Cord Length	Ship Weight
			L	D	H						
EDC36X	2	4	36	32.5	42.875	1/4	115/60/1	4.68	5-15P	10	297
EDC47X	2	6	48	32.5	42.875	1/4	115/60/1	3.12	5-15P	10	429
EDC64X	3	9	64	32.5	42.875	1/2	115/60/1	7.14	5-15P	10	484
EDC79X	3	9	82	32.5	42.875	3/4	115/60/1	7.14	5-15P	10	638