

Solid Hinged Lid Chest Freezers



Model	Size	Refrigerant
CF-30	30 Cu-Ft	R290

STANDARD FEATURES

- CFC free refrigerant and 2.95" foam insulation
- Thermometer supplied
- Control - Mechanical
- Operating temperature -11°F to 14°F
- Drainage is in front, easy to collect water
- Fast freeze time
- Extra strong handle
- L.E.D. Lights on Door Optional
- Door Locks
- Low noise level
- Internal coved corners, easy to clean
- Equipped with 6 rollers with brakes
- 2 Baskets Supplied, additional baskets available as option.
- Coated wire basket included
- Balance able hinges on the door, stop from 45° to 75° angle
- Power cord supplied, 6 foot length, NEMA5-15P
- Warranty: 1 year parts and labor



CONFORMS TO UL STD.NO.60335-2-89

CERTIFIED TO CSA STD. C22.2 NO.60335-2-89

Intertek
3 1 3 3 2 4 9

Intertek
3 1 3 3 2 4 9

CONFORMS TO NSF STD.7

*Not suitable for installation in a non-commercial or residential applications.

Items	Description
External top/side	White Precoated Steel
Door	White Precoated Steel
External back	White Precoated Steel
Cabinet internal	Embossed Aluminum
Internal floor	Embossed Aluminum
Insulation	2.95" foam
Lighting	L.E.D. Lighting Optional

Items	Description
Temperature control	Mechanical 1 to 7 is the coldest
Comply to standard	ANSI / NSF-7
Refrigerating system	Capillary tube
Refrigerant	R290
Temperature	-11°F to 14°F
Evaporator/Condenser	Aluminum + Copper
Condensing unit	Side mount
Doors	Hinged with door lock

FREEZERS



DETAILS AND DIMENSIONS

CF-30

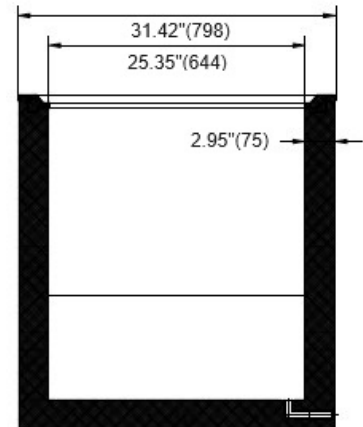
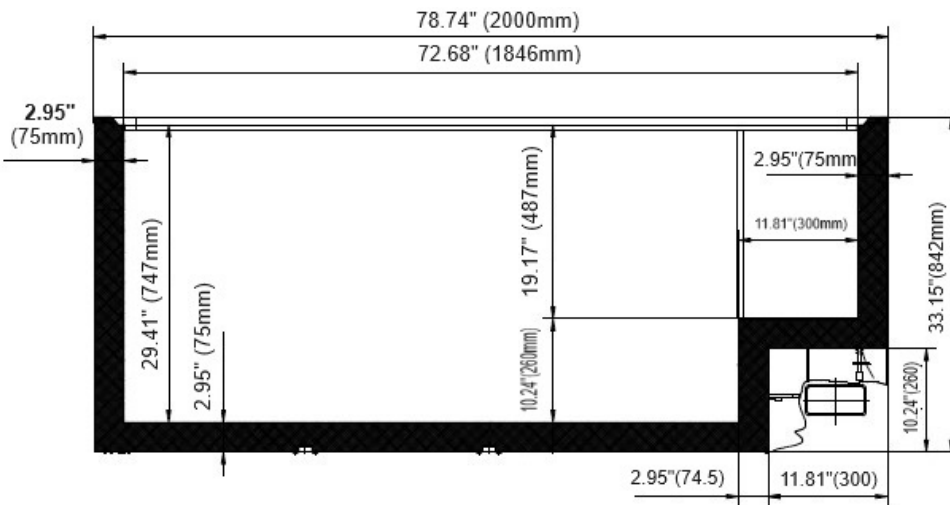
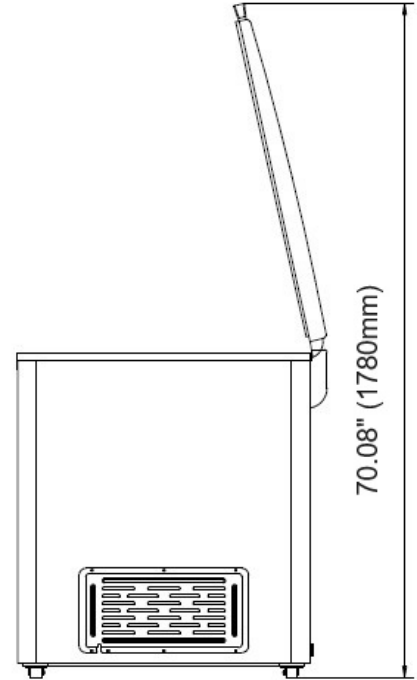
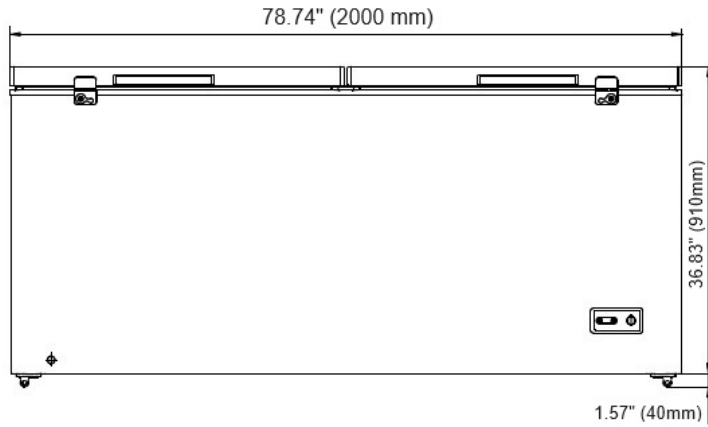
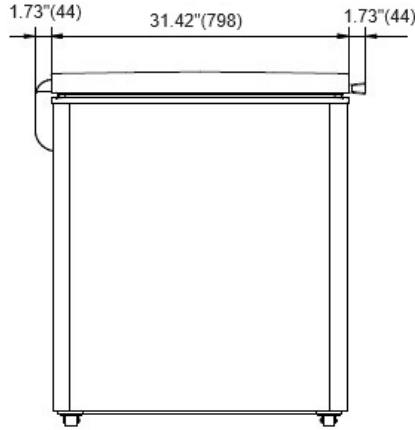

Model	# of Doors	# of Baskets	Appx Storage CAP (Cu-ft)	Cabinet Dim (in)			HP	Voltage /Hz /ph	Amp	NEMA Plug	Cord Lgth (ft)	Uncrated / Crated Weight
				W	D	H						
CF-24	2	2	30	78.7	34.88	38.4	4/5	115/60/1	4.6	5-20P	6.0	190/222