

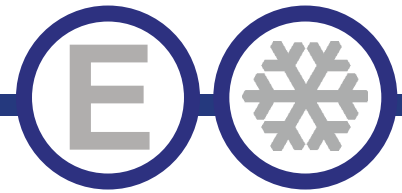

Series "A"



TOPPING RAILS With/With Out Cutting Board



Photo of ETR-46CB-HC Open with option cutting board

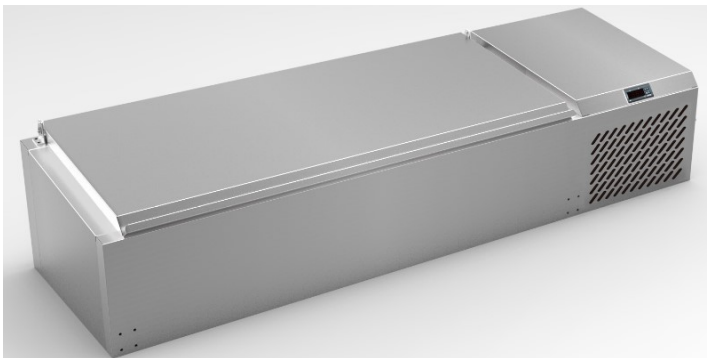

Photo of ETR-60-HC Cloaws without option cutting board

Model	Size
ETR-46-HC	46" Unit
ETR-46CB-HC	46" Unit
ETR-60-HC	60" Unit
ETR-60CB-HC	60" Unit

STANDARD FEATURES

- 304 Stainless steel exterior and interior.
- Refrigeration system keeps food at safe temperatures between 34°F and 38°F
- Electronic control system makes it easy to adjust temperature set point and defrost frequency.
- Easy to access condenser coil for cleaning and service.
- Uses R290 refrigerant, which is eco-friendly and more efficient.
- Lexan Pans included
- Cutting board optional.
- Warranty: One year parts & labor warranty.

*Not suitable for installation in a non-commercial or residential applications.

Items	Description	Items	Description
Front, top & sides	Stainless steel	Temperature control	Solid state thermostat/Digital display
External back	Stainless steel	Approvals	ETL LISTED
Interior	Stainless steel	Refrigerating system	Capillary tube
Insulation	Polyurethane (CFC free)	Refrigerant	R290
No Evaporator	Cold wall cooling	Temperature range	34°F to 38°F
Cutting Board	Vinyl (Optional)	Condensing unit	Side mounted

REFRIGERATION

CONFORMS TO NSF/ANSI STD 7

Customer Service (704) 900-2068 - Email: greatfood@entree.biz Website: www.entree.biz





DETAILS AND DIMENSIONS

ETR-46-HC & ETR-60-HC

Side View

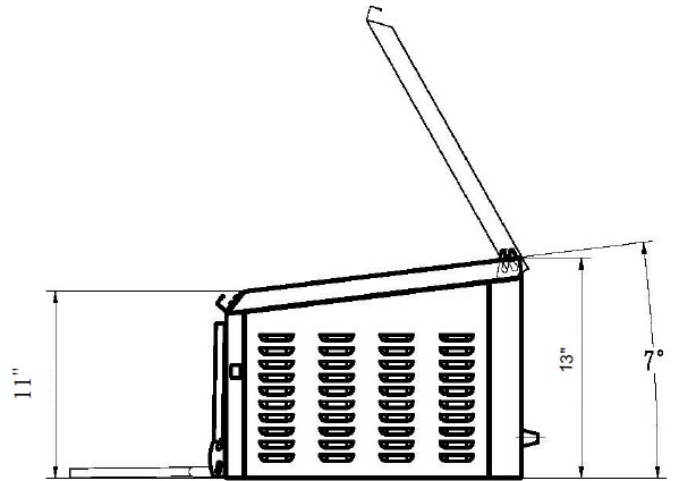
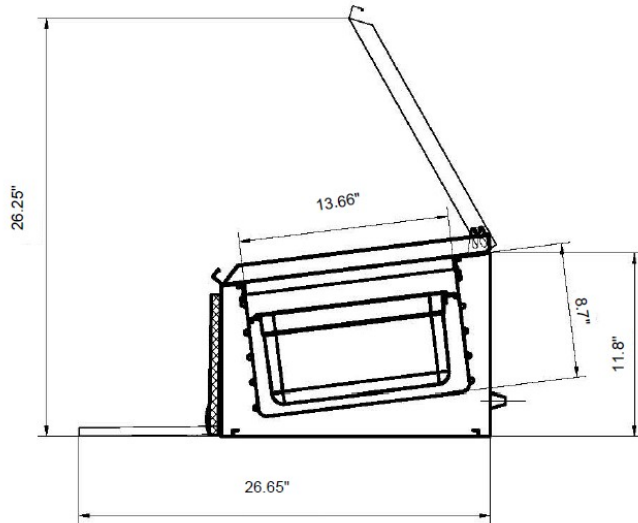

ETR-46-HC

ETR-60-HC

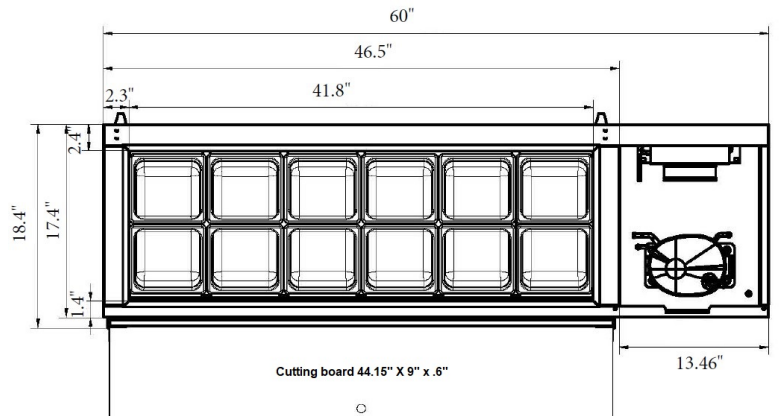
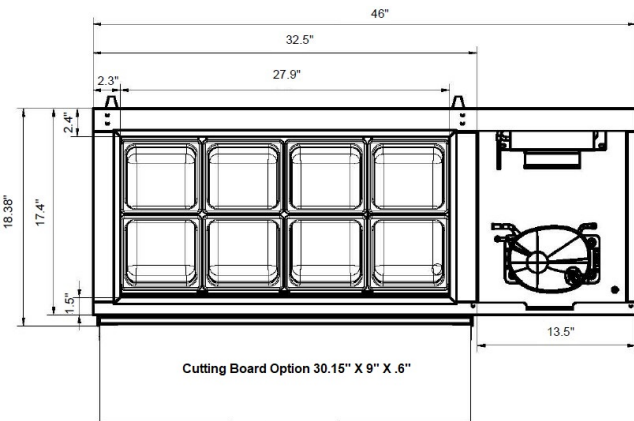
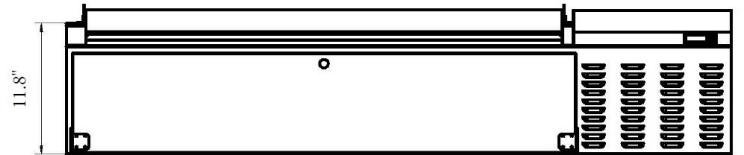

Model	Pans	Cutting Board	Cabinet Dim (inches)			HP	Voltage	Amps	NEMA Plug	Cord Length	Net Weight	Ship Weight
			W	D	H							
ETR-46-HC	8	No	45.8	17.4	13.5	1/5	115/60/1	2.0	5-15P	9.8'	81	117
ETR-46CB-HC	8	Yes	45.8	17.4	13.5	1/5	115/60/1	2.0	5-15P	9.8'	81	117
ETR-60-HC	12	No	60	17.4	13.5	1/5	115/60/1	2.0	5-15P	9.8'	99	141
ETR-60CB-HC	12	Yes	60	17.4	13.5	1/5	115/60/1	2.0	5-15P	9.8'	99	141