

CHILTOP BEER DISPENSER 27" DEPTH



Optional Towers w/Coupler



Model	Size
ECBD58-27X	58" Unit
ECBD69-27X	69" Unit
ECBD90-27X	90" Unit

STANDARD FEATURES

- Stainless steel top and interior, exterior coated steel.
- Cabinet and solid doors are foamed-in-place using a high density, polyurethane insulation.
- Refrigeration system keeps drinks at safe and cold temperatures between 33°F and 41°F
- Electronic control system makes it easy to adjust temperature set point and defrost frequency.
- **Tower options:** All models come standard with a 2 tap tower, add -1T or -3T to your model number for the one or three tap tower.
- Standard with towers and reinforced floor.
- Shelves: Adjustable heavy-duty PVC coated.
- Self-Closing doors with locks.
- Interior efficient LED lighting.
- Easy to access condenser coil for cleaning and service.
- 3" swivel casters included
- Uses R290 refrigerant, which is eco-friendly and more efficient.
- Warranty: Two year parts & labor warranty, and additional three years on compressor.

*Not suitable for installation in a non-commercial, residential applications.

Items	Description	Items	Description
Top & Interior	Stainless steel	Temperature control	Solid state thermostat/Digital display
Doors	Solid coated steel	Approvals	ETL LISTED
External back	Aluminum	Refrigerating system	Capillary tube
Cabinet interior	Stainless Steel	Refrigerant	R290
Interior floor	Reinforced Stainless steel	Temperature range	33F to 41°F
Insulation	High Density Polyurethane (CFC free)	Evaporator	Powder coated aluminum/copper
Shelves	Heavy duty, PVC coating	Condensing unit	Bottom mounted

CONFORMS TO NSF/ANSI STD 7

ECBD51-27X

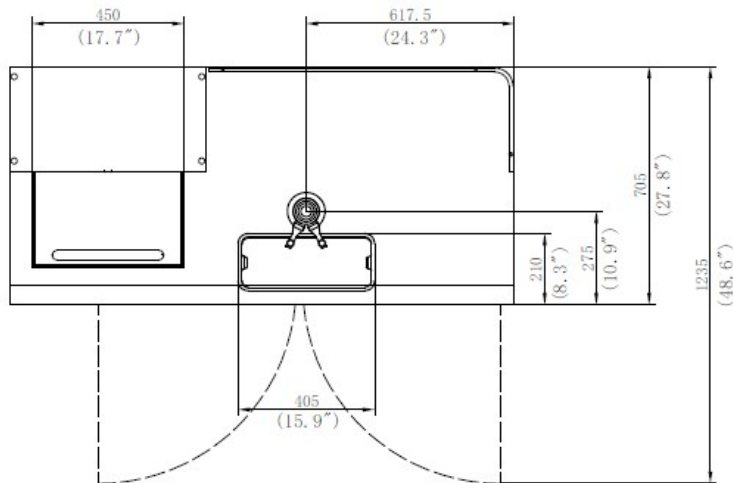
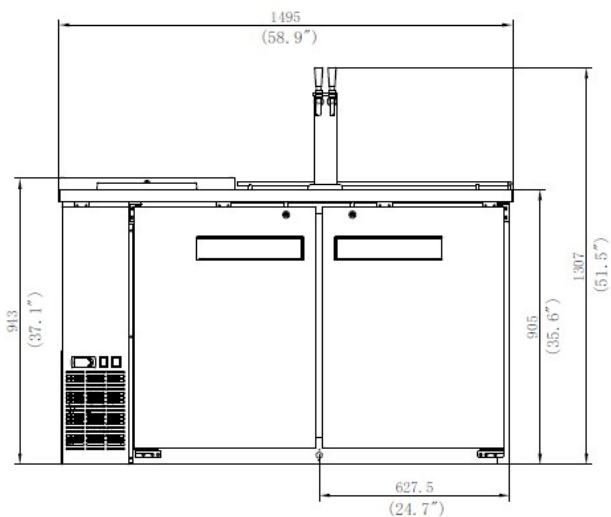

ECBD69-27X

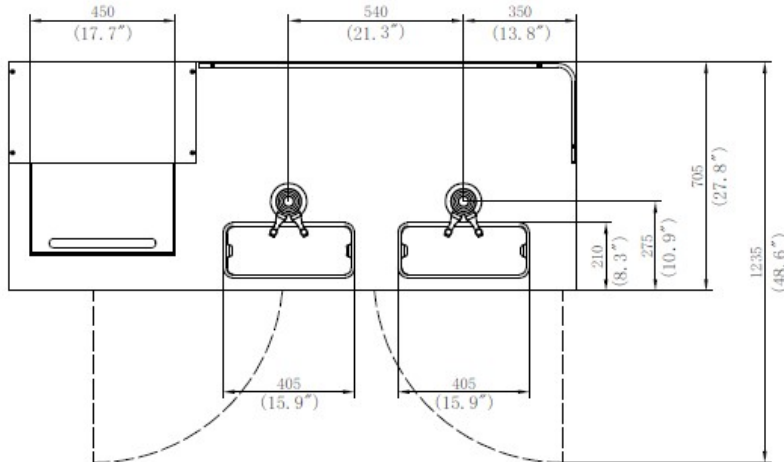
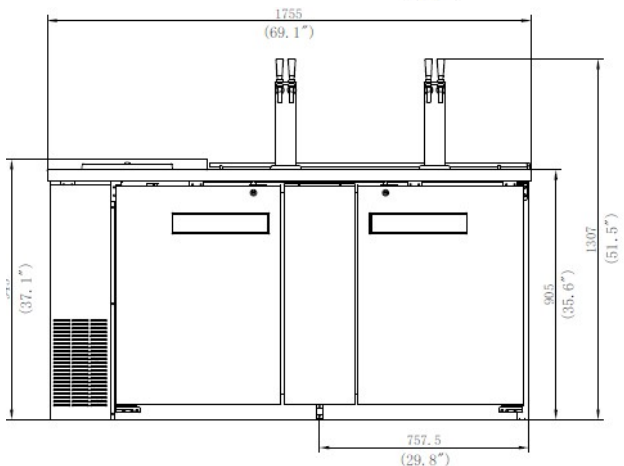

ECBD90-27x

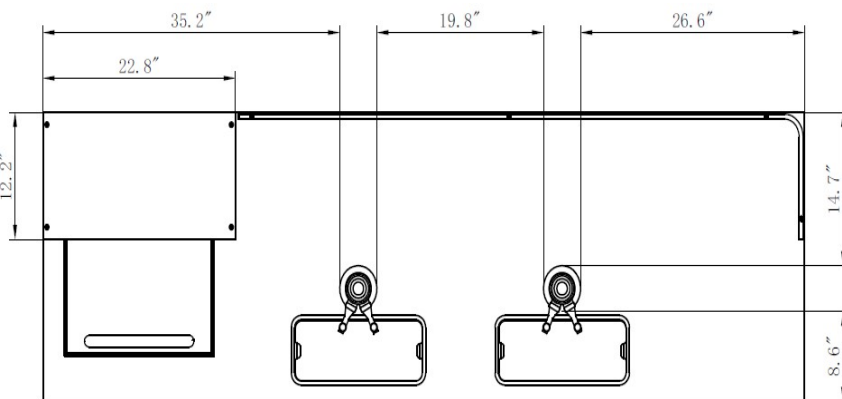
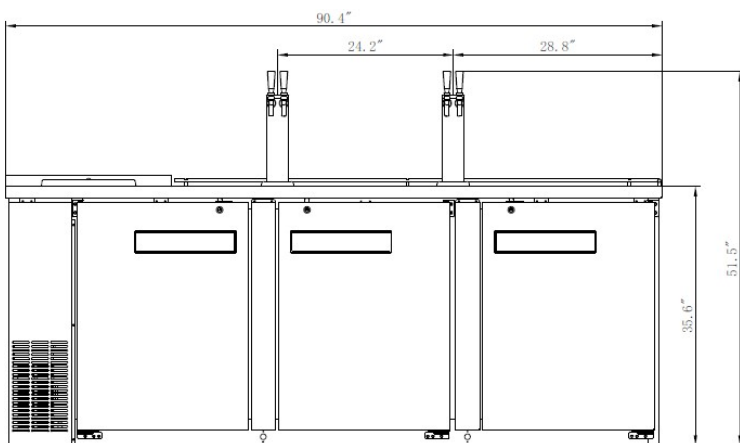

Model	Doors	Barrels 1/2 Keg / 50 L	Cabinet Dim (inches)			HP	Voltage	Amps	NEMA Plug	Cord Length	Ship Weight
			L	D	H						
ECBD57-27X	2	2 Barrels	58.9"	27.8"	37.1"	1/5	115/60/1	3.6	5-15P	10	282
ECBD69-27X	2	3 Barrels	69.1"	27.8"	37.1"	1/5	115/60/1	4.3	5-15P	10	319
ECBD90-27X	3	4 Barrels	90 3/8"	27.8"	37.1"	1/4+	115/60/1	4.8	5-15P	10	385

* Height does not include 15 1/4" for draft tower