

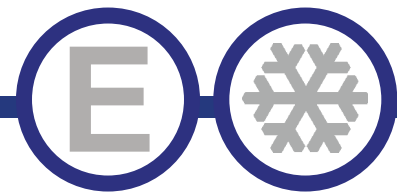

Series "A"



Glass Door Refrigerators



CR1-27-G-hc



CR2-54-G-HC

Model
CR1-27-G-HC
CR2-54-G-HC

STANDARD FEATURES

- CFC Free Refrigerant and foam
- For stainless steel interior add "-SI" example: CR1-27-G-SI-HC
- Solid state thermostat with digital display
- Stainless steel front and sides
- Heating element consealed in door frame to eliminate any condensation
- Self closing doors remain open past 90°
- Non twist solid mullions on 2 & 3 door units
- Environmentally friendly Freon
- EZ slide out condenser
- Integrated door handle
- Whisper quiet
- Solid construction
- Holds sheet pans front to back
- High efficiency polyurethane insulation
- Zero clearance sides, 2" minimum clearance back
- 2 Year Parts & Labor Warranty, additional 3 years on compressor

*Not suitable for installation in a non-commercial or residential applications.

Items	Description	Items	Description
Front, Top & Sides	430 Stainless steel	Temperature control	Solid State T-stat with Digital Display
Door	430 Stainless steel frame Glass Door	Comply to standard	ETL Listed
External back	430 Stainless steel	Refrigerating system	Capillary tube
Cabinet internal	Powder Coated Aluminum	Refrigerant	R290
Internal floor	Powder Coated Aluminum	Temperature Range	34°F — 38°F
Insulation	Polyurethane (CFC free)	Evaporator/Condenser	Aluminum + Copper
Shelves	Heavy duty, PVC coating – 3 or 4 layers	Condensing unit	Bottom Mounted

REFRIGERATION / FREEZERS



DETAILS AND DIMENSIONS

CR1-27-G-HC

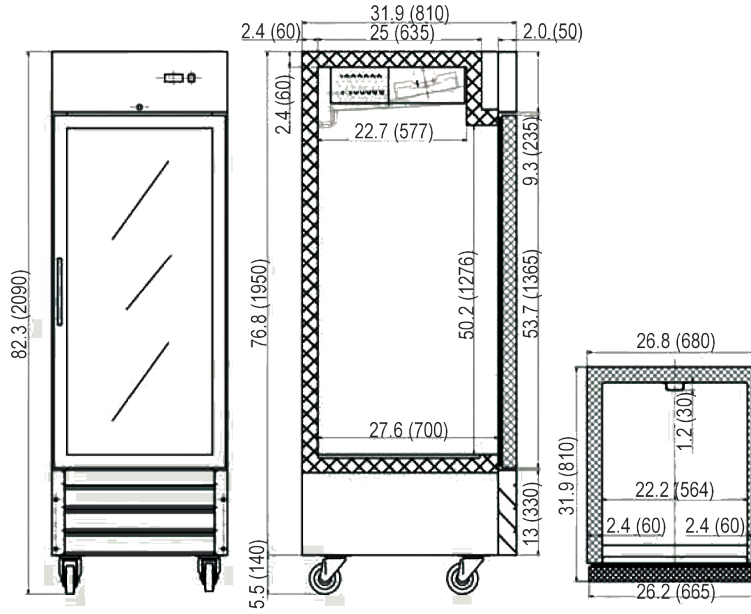

CR2-54-G-HC

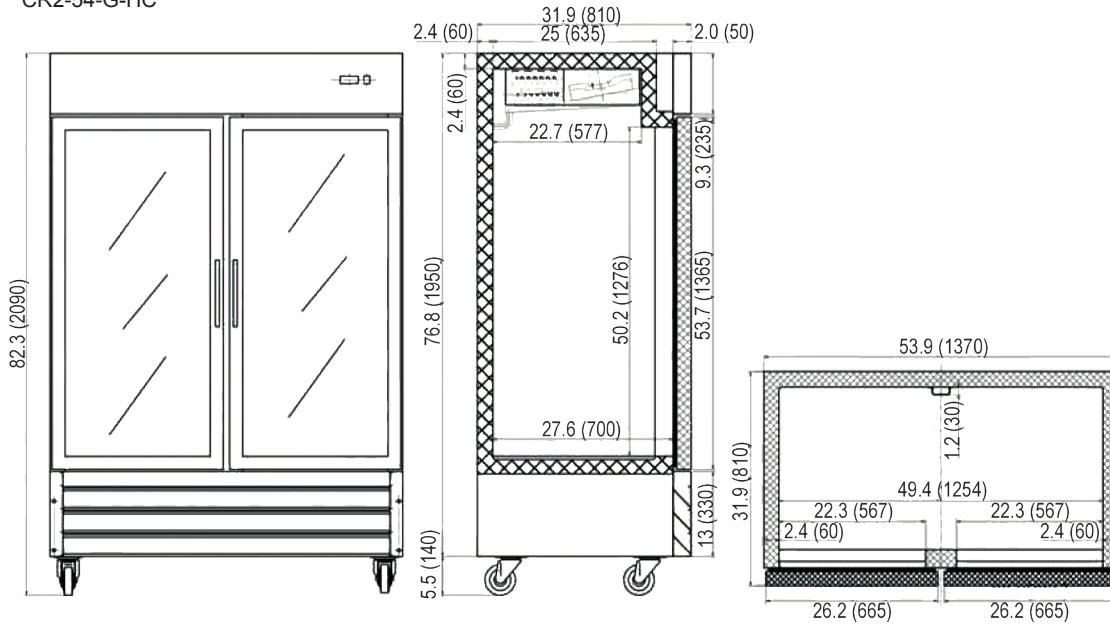

Model	Doors	Shelves	Cabinet Dim (in)			HP	Voltage /Hz /ph	Amp	NEMA Plug	Cord Lgth (ft)	Crated Weight (lbs)
			W	D	H						
CR1-27-G-HC	1	4	26.8	31.9	82.7	1/5	115/60/1	3.0	5-15P	10	366
CR2-54-G-HC	2	8	53.9	31.9	82.7	1/4	115/60/1	4.5	5-15P	10	597