

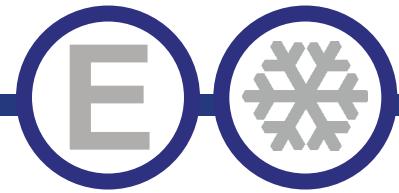

Series "A"



Direct Draw Beer Dispensers



BCBD1-HC



BCBD2-1-HC



BCBD2-2-HC

Model	Number of Faucets
BCBD1-SI-HC	1
BCBD2-1-SI-HC	2
BCBD2-2-SI-HC	2

STANDARD FEATURES

- Designed to accommodate a variety of beer kegs
- 3" diameter stainless steel insulated beer column
- Cold air is channeled directly into beer column to reduce foaming and maximize beer draft profits.
- Stainless Steel interior - s/s 430
- Powder-mated steel black exterior
- Warranty: 2 years parts and labor additional 3 years- compressor

Not suitable for installation in a non-commercial or residential applications.

Items	Description	Items	Description
External top/side	Powder matted steel	Temperature control	Solid State T-stat with Digital Display
Interior	Stainless steel	Comply to standard	ETL LISTED, ANSI / NSF-7
External back	Powder matted steel	Refrigerating system	Capillary tube
Cabinet internal	430 stainless steel	Refrigerant	R290
Internal floor	430 stainless steel	Temp. Range in box	33°F — 41°F
Insulation	Polyurethane (CFC free)	Evaporator/Condenser	Aluminum + Copper
Dividers	Heavy duty, Epoxy coating – 3 or 4 layers	Condensing unit	Side Mount
Lighting	LED	Doors	Hinged Doors

BEER DISPENSERS



DETAILS AND DIMENSIONS

BCBD1-SI-HC

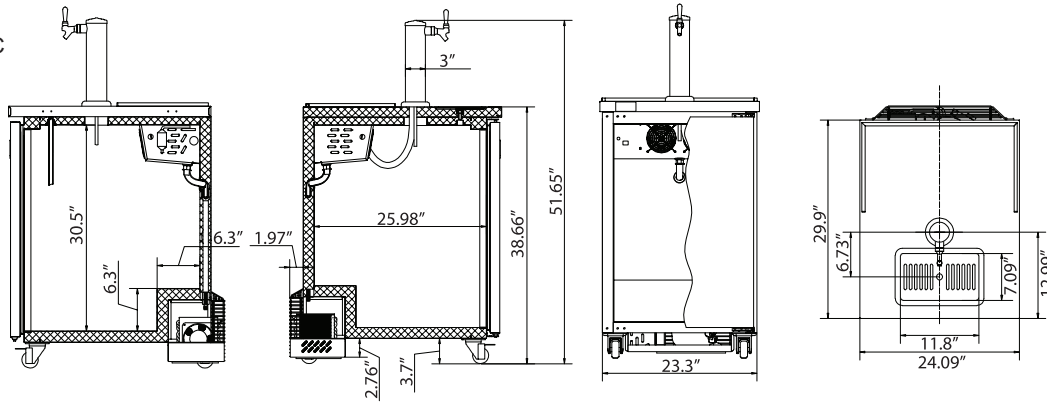

BCBD2-1-SI-HC

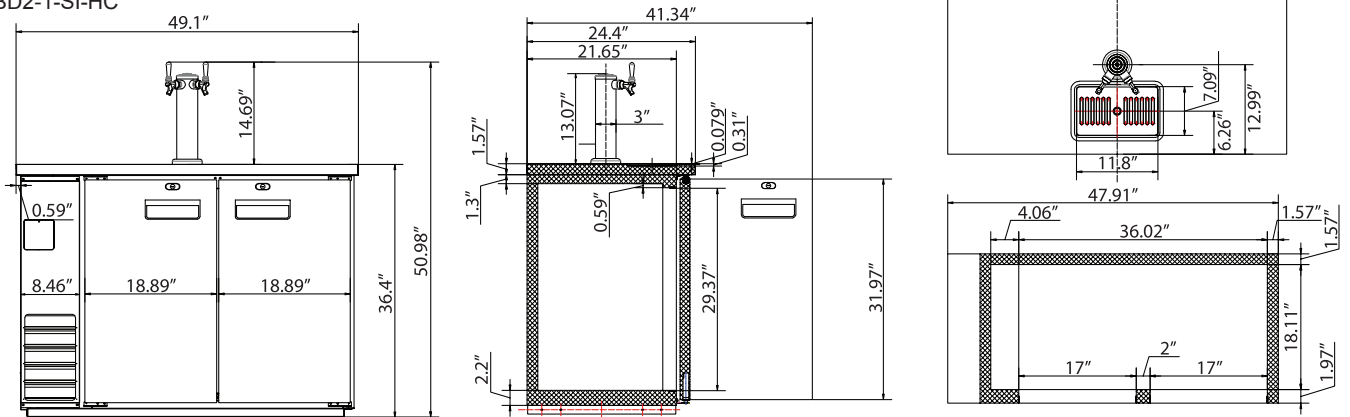

BCBD2-2-SI-HC

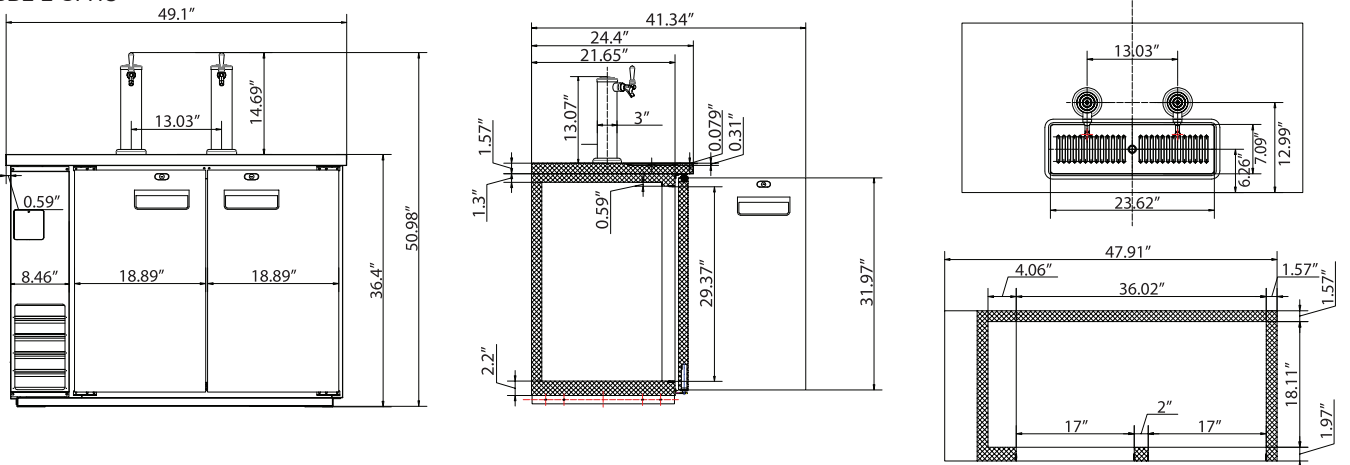

Model	# of Faucets	External Dim (in)			HP	Voltage /Hz /ph	Amp	NEMA Plug	Cord Lgth (ft)	Crated Weight (lbs)
		W	D	H						
BCBD1-SI-HC	1	24.1	29.9	38.6	1/8	115/60/1	2.2	5-15P	8.2	161
BCBD2-1-SI-HC	2	49.1	24.4	36.4	2/5	115/60/1	3.0	5-15P	8.2	271
BCBD2-2-SI-HC	2	49.1	24.4	36.4	2/5	115/60/1	3.0	5-15P	8.2	280