

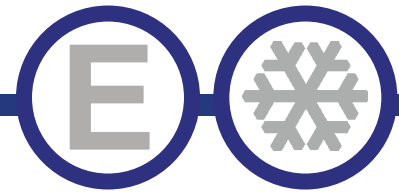

Series "A"



Solid Door Back Bottle Coolers (side mount compressor)



BB-2D-60-HC



BB-2D-70-HC

Model	Size
BB-2D-60-HC	Two Door
BB-2D-70-HC	Two Door
BB-3D-90-HC	Three Door

STANDARD FEATURES

- Bright LED lighting standard on all back bar coolers
- CFC free refrigerant and foam with self contained capillary tube system
- Electronic thermostat and digital LED temperature display for accurate control and easy reading
- Self-closing door
- Four casters- two front locking
- Magnetic gasket can be replaced without a tool
- Warranty: 2 years parts and labor
additional 3 years- compressor



BB-3D-90-HC

***Not suitable for installation in a non-commercial or residential applications.**

Items	Description	Items	Description
External top/side	430 stainless steel	Temperature control	Solid State T-stat with Digital Display
Door	Painted black	Comply to standard	ETL LISTED, ANSI / NSF-7
External back	Painted black	Refrigerating system	Capillary tube
Cabinet internal	Stainless steel	Refrigerant	R290
Internal floor	Stainless steel	Temp. Range in box	33°F — 38°F
Insulation	Polyurethane (CFC free)	Evaporator/Condenser	Aluminum + Copper
Lighting	LED	Condensing unit	Side Mount
		Doors	Solid Doors

BOTTLE COOLERS



DETAILS AND DIMENSIONS

BB-2D-60-HC

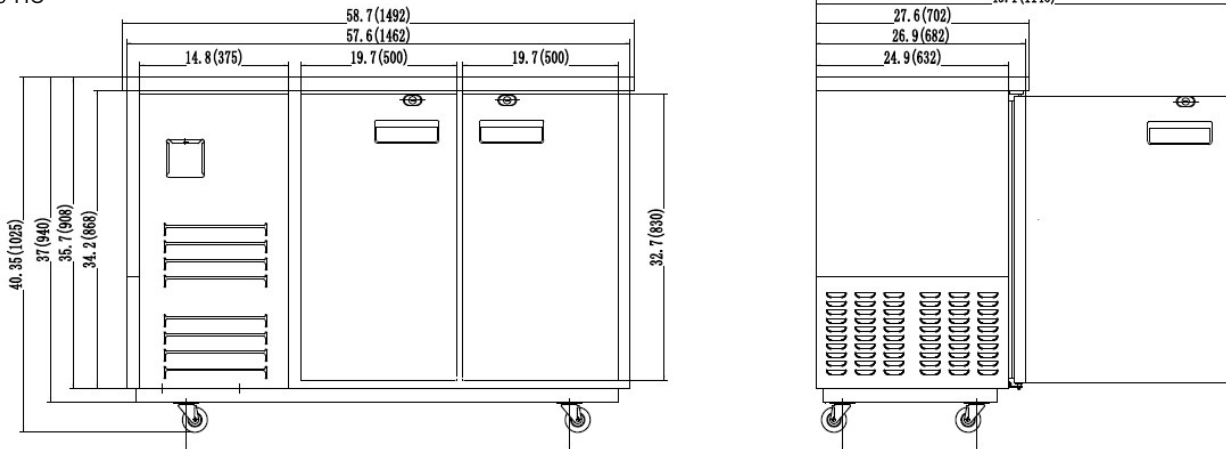

BB-2D-70-HC

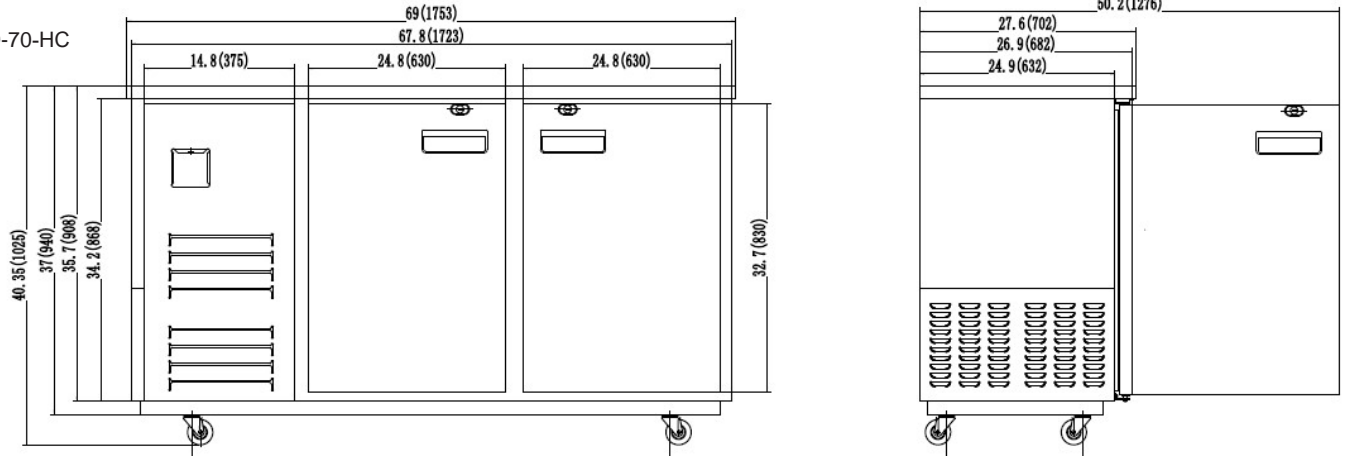

BB-3D-90-HC

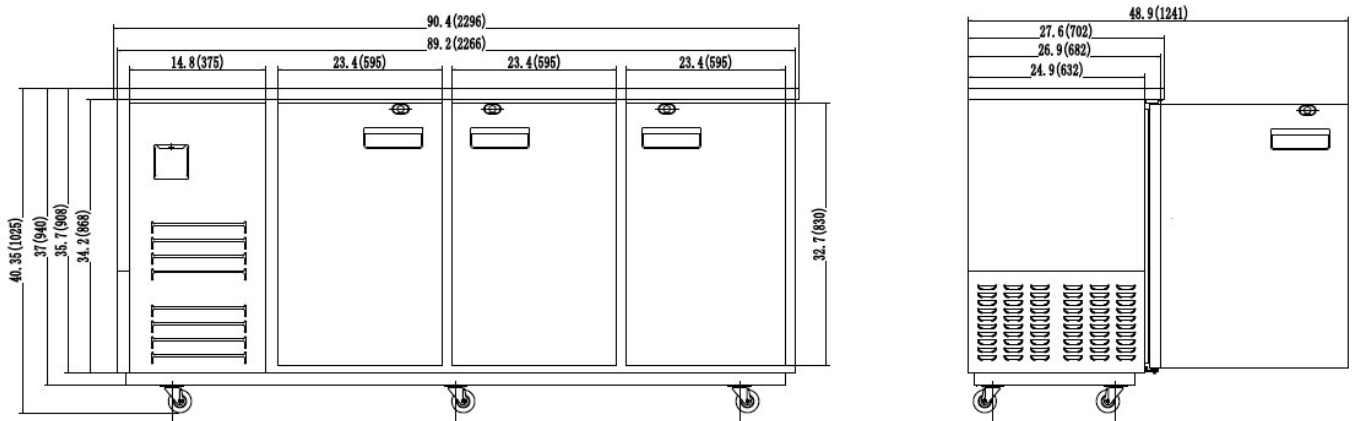

Model	# of Doors	Shelves	Cabinet Dim (in)			HP	Voltage /Hz /ph	Amp	NEMA Plug	Cord Lgth (ft)	Crated Weight (lbs)
			W	D	H						
BB-2D-60-HC	2	4	58.7	27.6	40.35	3/8	115/60/1	3.0	5-15P	8.2	302
BB-2D-70-HC	2	4	69	27.6	40.35	3/8	115/60/1	3.0	5-15P	8.2	355
BB-3D-90-HC	3	6	90.4	27.6	40.35	1/2	115/60/1	3.0	5-15P	8.2	412