

# COMMERCIAL ELECTRIC CONVECTION OVEN



Model	#Ovens	VAC
ECO-1-208	1	208
ECO-1-240	1	240

## STANDARD FEATURES

### Construction

- Stainless Steel Front and Angular Legs
- Double pane thermal glass windows on doors
- Steel legs with adjustable bullet feet
- Doors have an interlock switch that automatically turns the fan and elements off when open
- 

### Oven Features

- Easy to Clean Full Porcelain Oven Interior.
- Oven interior measures 28.25" x 21.5" x 20"
- 1/2 HP two speed fan motor
- Cooking chamber is lined with porcelain enamel
- 10 position guide rack with 1.5" spacing in between
- 5 heavy duty adjustable chrome plated racks
- Seamless interior and corners for easy cleaning

### Controls

- Accurate solid state oven thermostat with a range from 150°F - 500°F
- 60 minute continuous ring timer - manual shut off
- Temperature ready indicator light

**Note: Double Deck ovens are shipped as single decks.**

Entrée's Full Size Electric Convection Oven is ideal for any high volume restaurant or food service establishment. Constructed of stainless steel, this oven operates with a forced air, two speed fan motor system with a cool down feature. The interior of the oven has a 10 position rack guide and fits full size sheet pans. Electronic controls featuring a 60 minute timer and manual temperature knob. The double pane glass doors have a interlock switch that automatically turns the fan and elements off when they are opened. Includes stainless steel legs and adjustable bullet feet.

COMMERCIAL COOKING

**Warranty: Entrée's exclusive parts and labor FUSS warranty takes effect at time of purchase for 1 year.**

**\*Not suitable for installation in a non-commercial or residential applications**

Customer Service (704) 900-2068 - [www.entree.biz](http://www.entree.biz) Email: [greatfoods@entree.biz](mailto:greatfoods@entree.biz)





# DETAILS AND DIMENSIONS

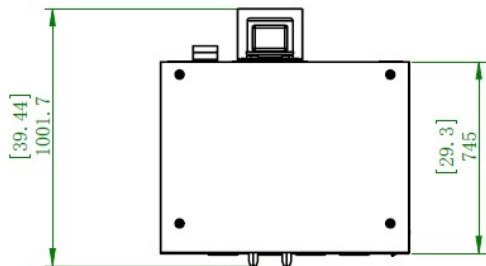
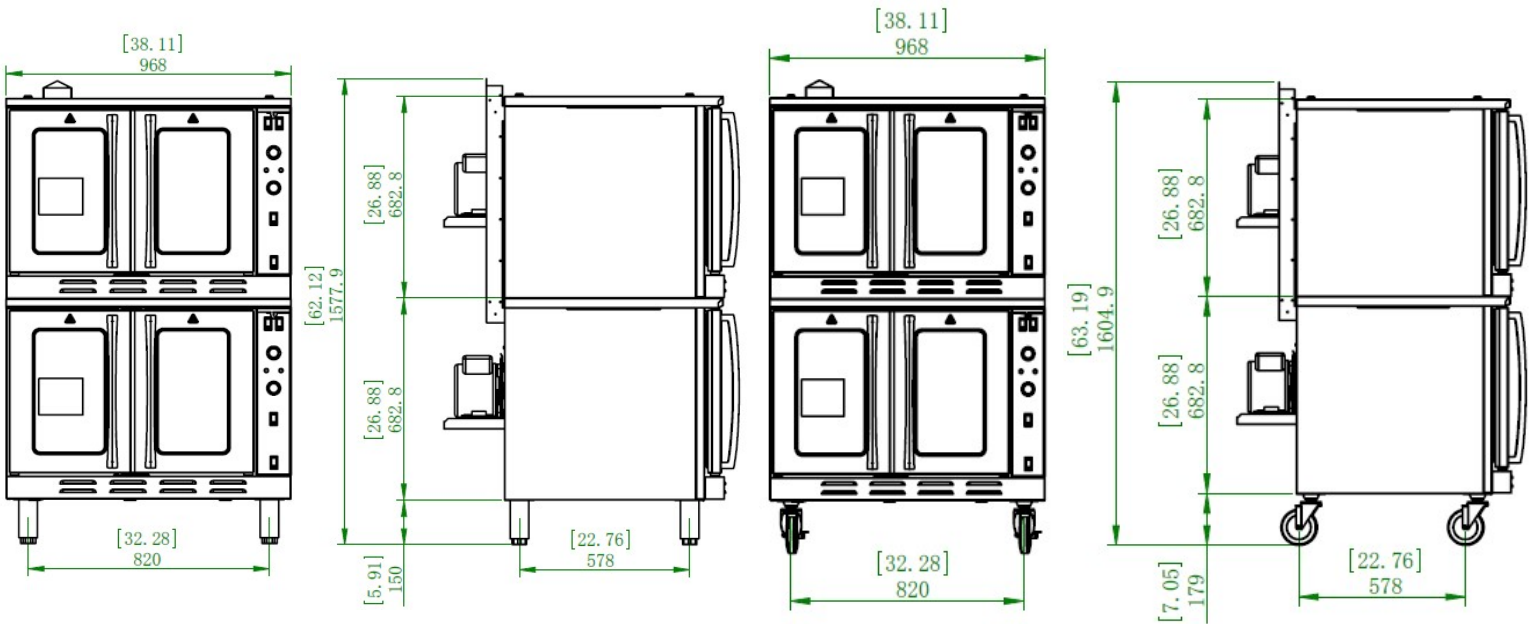
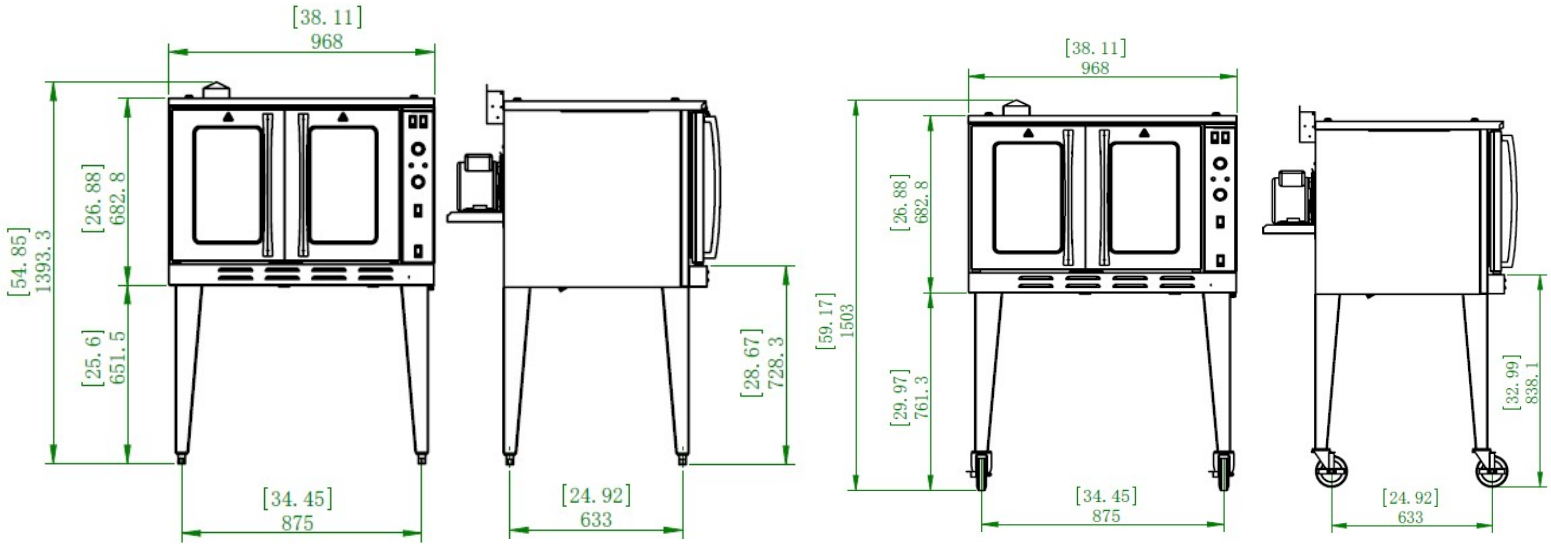
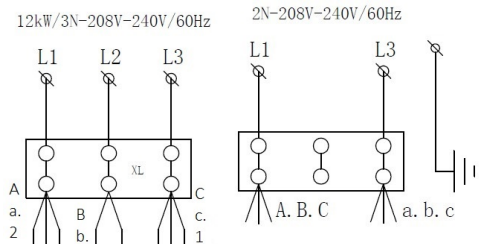

Diagram at right showing 3 phase and single phase connection.



Model	Racks	External Dimensions			Internal Oven Dimensions			Total kW's	AMP/Phase				Volts	Crated Weight (lbs)
		W	D	H	W	D	H		Single Phase	Three Phase				
										L1	L2	L3		
ECO-1-208	5	38.1	39.5	54.85	28.5	21.5	20	9.0	43	27	24	27	208VAC	579
ECO-1-240	5	38.1	39.5	54.82	28.5	21.5	20	11.9	50	30	27	30	240VAC	579