

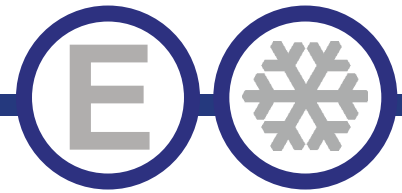

Series "B"



CAKE DISPLAY CASES

Two Layer Shelves



ECD35-2X



ECD47-2X



ECD59-2X



ECD71-2X

Model	Size
ECD35-2X	35" Unit
ECD47-2X	47" Unit
ECD59-2X	59" Unit
ECD71-2X	70" Unit

STANDARD FEATURES

- Exterior floor and walls, standard.
- Refrigeration system keeps food at safe temperatures between 36°F and 43°F
- Sliding glass doors
- Shelves: Adjustable glass shelves provide extra large viewing area to maximize bakery product presentation.
- Tempered Glass to avoid injury by broken glass.
- Electronic control system makes it easy to adjust temperature set point and defrost frequency.
- Pre-installed 2" swivel casters.
- Easy to access condenser coil for cleaning and service.
- Uses R290 refrigerant, which is eco-friendly and more efficient.
- Interior efficient LED lighting
- NSF-7 compliant for open food product
- Warranty: One year parts & labor warranty, and additional two years on compressor.

*Not suitable for installation in a non-commercial or residential applications.

Items	Description	Items	Description
Exterior	Stainless steel / Glass	Temperature control	Solid state thermostat/Digital display
Doors	Glass Sliding	Approvals	ETL LISTED
External back	Stainless Steel / Glass	Refrigerating system	Capillary tube
Cabinet interior	Glass	Refrigerant	R290
Interior floor	Stainless steel	Temperature range	36°F to 43°F
Insulation	Polyurethane (CFC free)	Evaporator	Powder coated aluminum/copper
Shelves	Heavy duty, PVC coating	Condensing unit	Bottom mounted

CONFORMS TO NSF/ANSI STD 7

REFRIGERATION





DETAILS AND DIMENSIONS

ECD35-2X FRONT

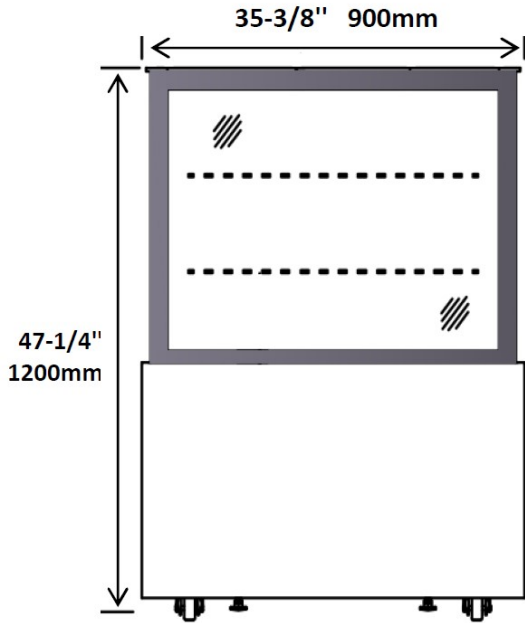

ECD35-2X REAR

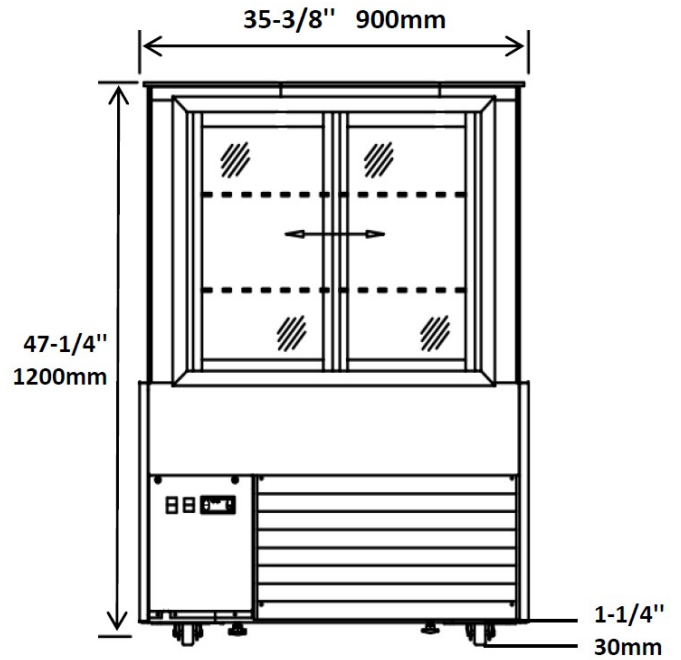

ECD47-2X FRONT

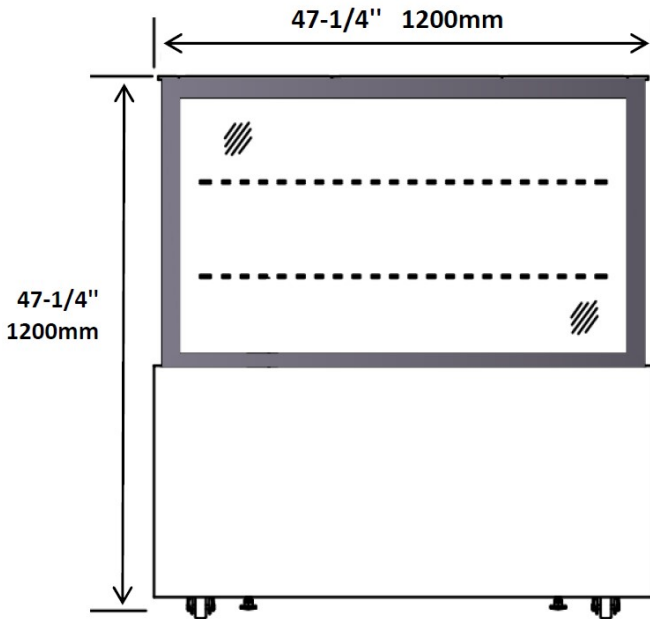

ECD47-2X REAR

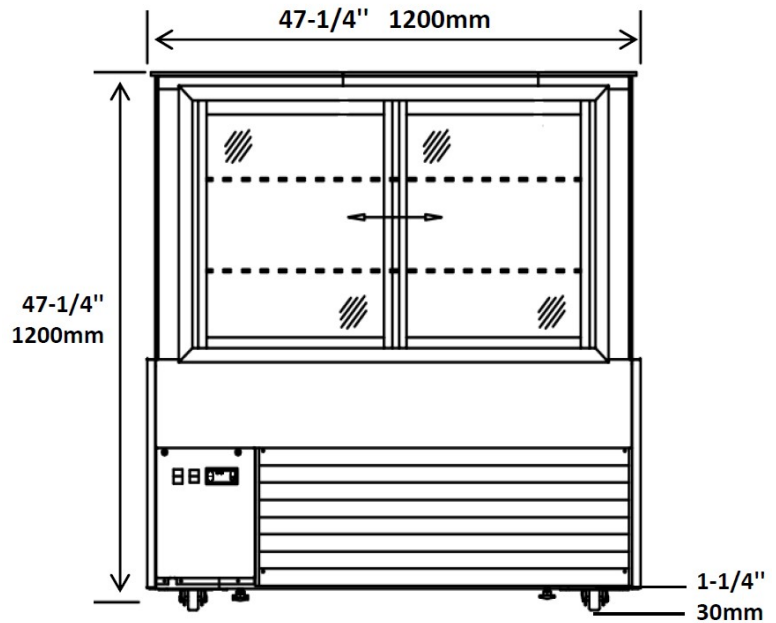

Model	Doors	Shelves	Cabinet Dim (inches)			HP	Voltage	Amps	NEMA Plug	Cord Length	Ship Weight
			L	D	H						
ECD35-2X	2	2	35.375	28.75	47.25	1/4	115/60/1	4.8	5-15P	10	352
ECD47-2X	2	2	47.25	28.75	47.25	1/4	115/60/1	5.58	5-15P	10	418
ECD59-2X	2	2	58.125	28.75	47.25	1/2	115/60/1	9.96	5-15P	10	506
ECD71-2X	2	2	70.875	28.75	47.25	3/4	115/60/1	11.04	5-15P	10	550



DETAILS AND DIMENSIONS

ECD59-2X FRONT

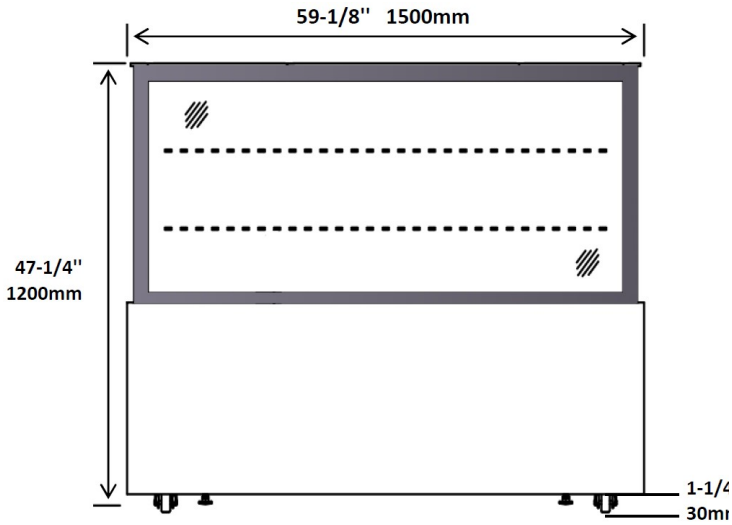

ECD59-2X REAR

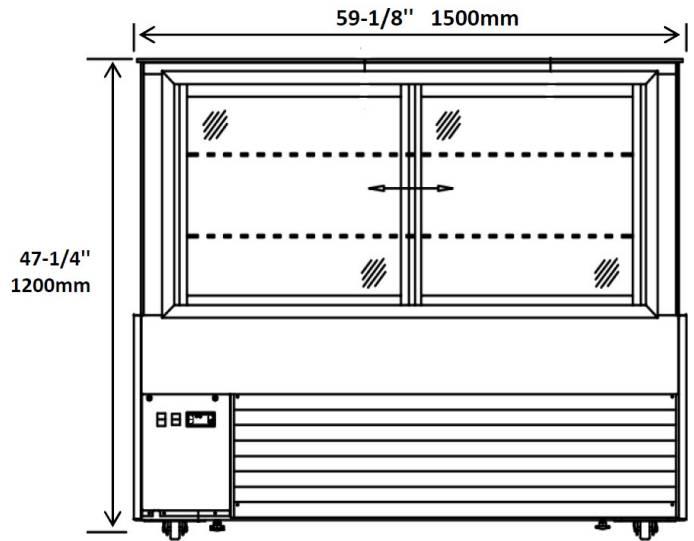

ECD71-2X FRONT

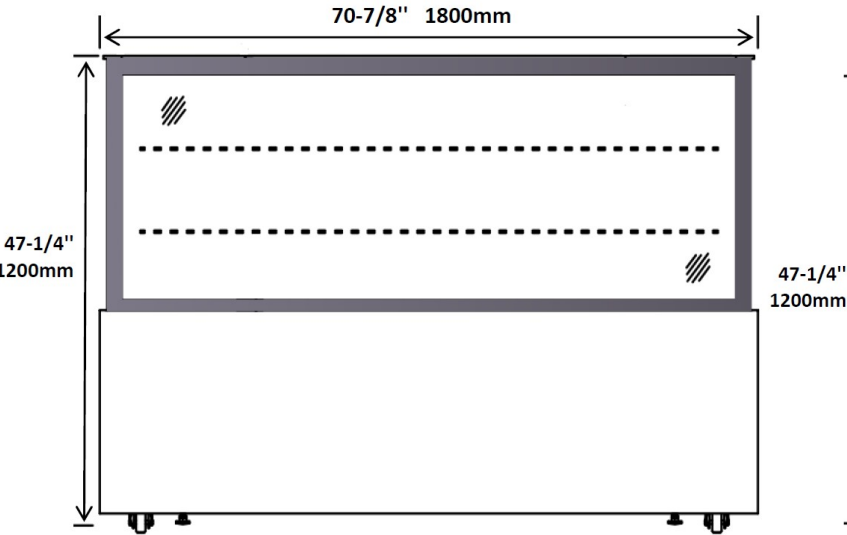

ECD71-2X REAR

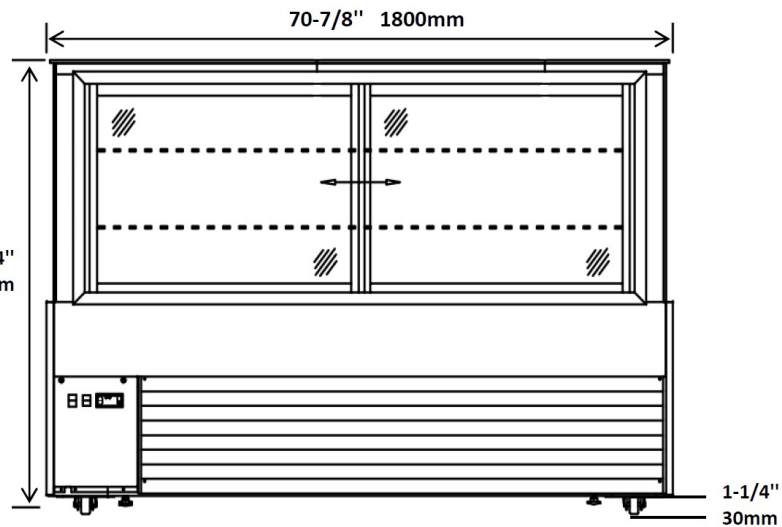

Model	Doors	Shelves	Cabinet Dim (inches)			HP	Voltage	Amps	NEMA Plug	Cord Length	Ship Weight
			L	D	H						
ECD35-2X	2	2	35.375	28.75	47.25	1/4	115/60/1	4.8	5-15P	10	352
ECD47-2X	2	2	47.25	28.75	47.25	1/4	115/60/1	5.58	5-15P	10	418
ECD59-2X	2	2	58.125	28.75	47.25	1/2	115/60/1	9.96	5-15P	10	506
ECD71-2X	2	2	70.875	28.75	47.25	3/4	115/60/1	11.04	5-15P	10	550



DETAILS AND DIMENSIONS

SIDE VIEW ALL

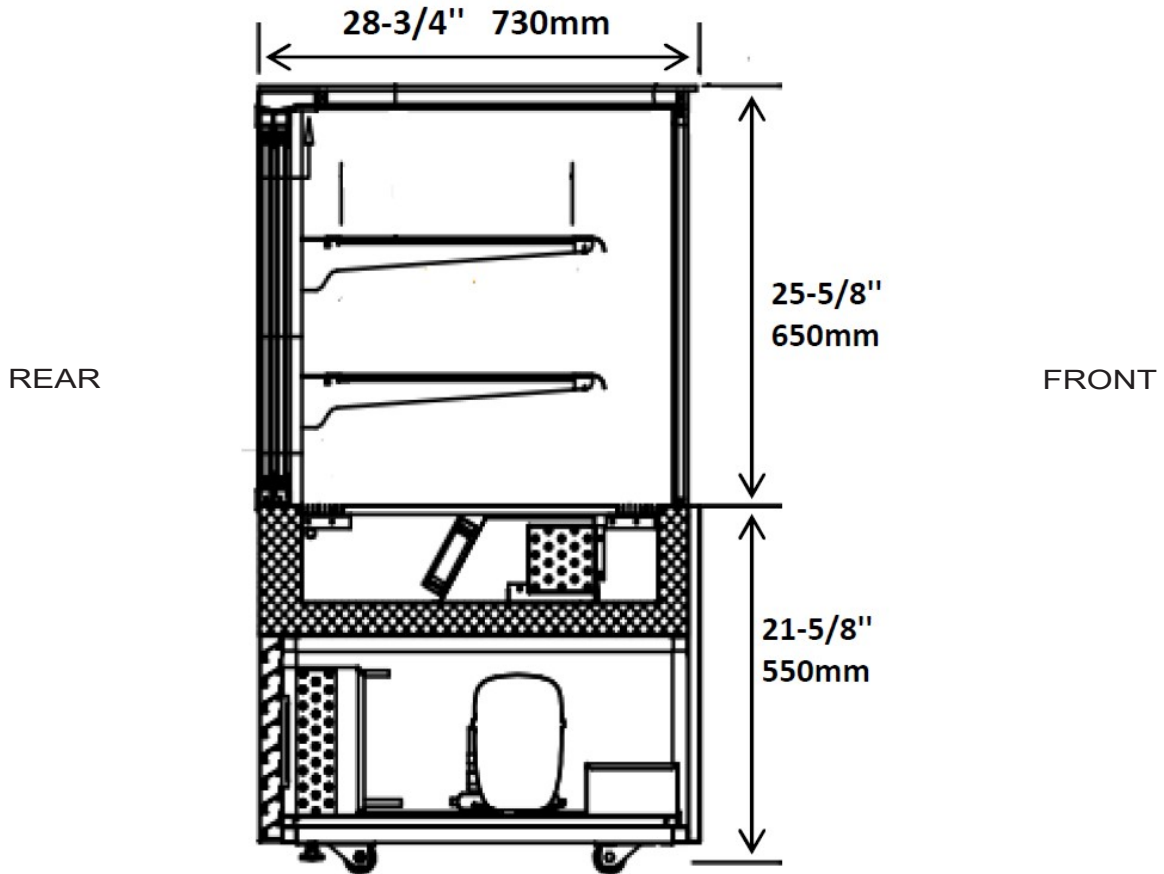

Model	Doors	Shelves	Cabinet Dim (inches)			HP	Voltage	Amps	NEMA Plug	Cord Length	Ship Weight
			L	D	H						
ECD35-2X	2	2	35.375	28.75	47.25	1/4	115/60/1	4.8	5-15P	10	352
ECD47-2X	2	2	47.25	28.75	47.25	1/4	115/60/1	5.58	5-15P	10	418
ECD59-2X	2	2	58.125	28.75	47.25	1/2	115/60/1	9.96	5-15P	10	506
ECD71-2X	2	2	70.875	28.75	47.25	3/4	115/60/1	11.04	5-15P	10	550