

## COMMERCIAL ELECTRIC COUNTER PANINI GRILL



### STANDARD FEATURES

- Thermostat Control with maximum temperature of 300°F
- Several types of grill surfaces. All grills are cast-iron with ceramic coating for "non-stick" performance
- Stainless Steel Front and side and Nonslip legs
- Fitted flat tray and back splash for easy cleaning
- Compact design for maximum cooking and using minimal counter space
- Front drain for easy water removal
- Durable knobs
- Supplied with power cord and OS-3J 6-20P
- Self contained heating element with powerful 1750 watts



*Entrée's Electric Counter Panini* is ideal for any counter top in restaurants or food service establishment for making those special sandwiches and other tasty food products. All grills, upper and lower are ceramic coated cast iron for even heat distribution with non-stick surface. With a variety of models that will perform differently. Choose from grooved up and lower to smooth upper and lower, or a combination of either. Comes with utensils for cleaning.

Whether you are cooking chicken or burgers, they are versatile for any types of sandwiches. All models are 120VAC and come with a NEMA 5-20P & 5' cord set.

**Warranty: Entrée's exclusive parts and labor FUSS warranty takes effect at time of purchase for 1 year.**

**\*Not suitable for installation in a non-commercial or residential applications**

Customer Service (704) 900-2068 - email: [greatfoods@entree.biz](mailto:greatfoods@entree.biz) [www.entree.biz](http://www.entree.biz)



COMMERCIAL COOKING



# DETAILS AND DIMENSIONS

Add Suffix - \*G=Top & Bottom Grooved

\*S=Top & Bottom Smooth

\*GS=Top Grooved & Bottom Smooth



EPG12\*  
12.2"(310mm)



EPG16\*  
16.1"(410mm)

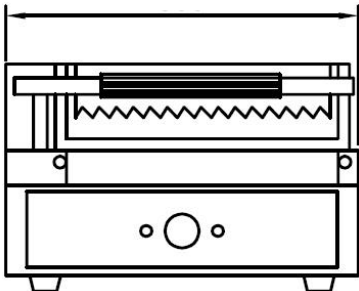

SIDE VIEW ALL  
15.6"(395mm)

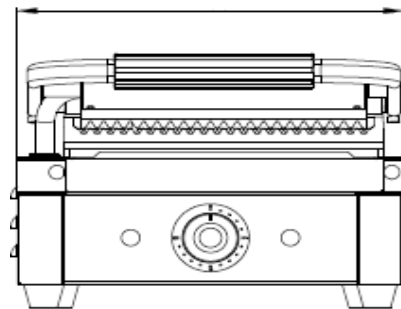

EPG23\*  
22.4" (570mm)

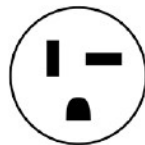
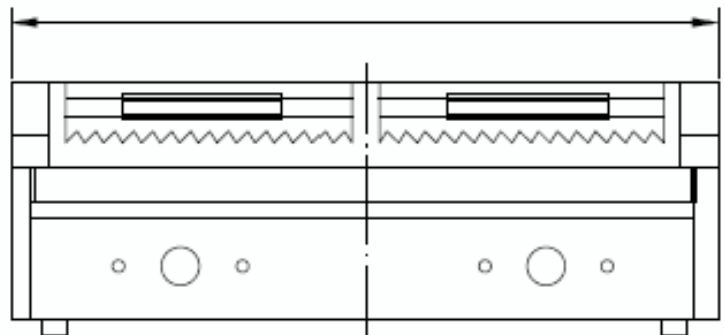
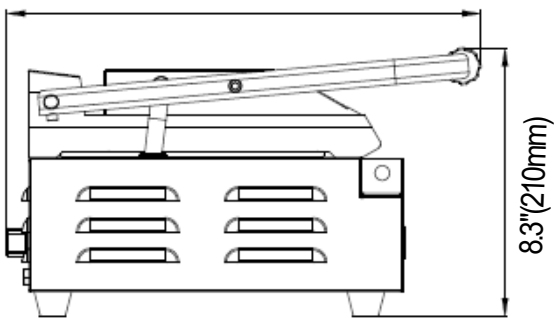

Drawing of  
OS-3J 6-20P Plug

Model	Width In/mm	Depth In/mm	Height In/mm	Heating Elements	Voltage	Power	Amp	Net Weight	Shipping Weight	Cord Length & Type
EPG12	11.8"/300	12"/305	8.25"/210	2	120	1750	14.6	31 lbs./14 kg	36 lbs./16 kg	5' NEMA 5-20P
EPG16	16"/410	12"/305	8.25"/210	2	120	1750	14.6	42 lbs./19 kg	47 lbs./21 kg	5' NEMA 5-20P
EPG23	22.5"/570	12"/305	8.25"/210	4	120	1750*2	14.6*2	62 lbs./28 kg	67 lbs./30 kg	5' NEMA 5-20P*2