



Gas Regulator Included

COMMERCIAL GAS CONVECTION OVEN



Model	#Ovens	Gas
CO-1-N	1	N
CO-1-P	1	P

STANDARD FEATURES

Construction

- Stainless Steel Front and Angular Legs
- Double pane thermal glass windows on doors
- Steel legs with adjustable bullet feet
- Doors have an interlock switch that automatically turns the fan and burners off when open
- 3/4" rear NPT gas connection

Oven Features

- Easy to Clean Full Porcelain Oven Interior.
- Oven interior measures 28.25" x 21.5" x 20"
- 1/2 HP two speed fan motor
- Cooking chamber is lined with porcelain enamel
- 10 position guide rack with 1.5" spacing in between
- 5 heavy duty adjustable chrome plated racks
- Seamless interior and corners for easy cleaning

Controls

- Accurate solid state oven thermostat with a range from 150°F - 550°F
- 60 minute continuous ring timer - manual shut off
- Temperature ready indicator light
- 6' power cord with NEMA 5-15 Plug

Note: Double Deck ovens are shipped as single decks.

Entrée's Full Size Gas Convection Oven is ideal for any high volume restaurant or food service establishment. Constructed of stainless steel, this oven operates with a forced air, two speed fan motor system with a cool down feature. The interior of the oven has a 10 position rack guide and fits full size sheet pans. Electronic controls featuring a 60 minute timer and manual temperature knob. The double pane glass doors have an interlock switch that automatically turns the fan and burners off when they are opened. Includes stainless steel legs and adjustable bullet feet.

Warranty: Entrée's exclusive parts and labor FUSS warranty takes effect at time of purchase for 1 year.

***Not suitable for installation in a non-commercial or residential applications**

Customer Service (704) 900-2068 - Fax (888) 388-6017 - www.entree.biz



COMMERCIAL COOKING



DETAILS AND DIMENSIONS

IMPORTANT INFORMATION:

- A combination safety valve with built-in pressure regulator is provided with this unit.
Natural Gas 4.0" W.C. Propane Gas 10.0" W.C.
- Gas connection is 3/4" NPT rear gas connection. If using Flex-Hose, the I.D. for single deck should be a minimum 3/4" and double deck 1" and must comply with ANSI Z 21.69
- All equipment is supplied for Natural Gas, an LPG conversion kit is also provided.

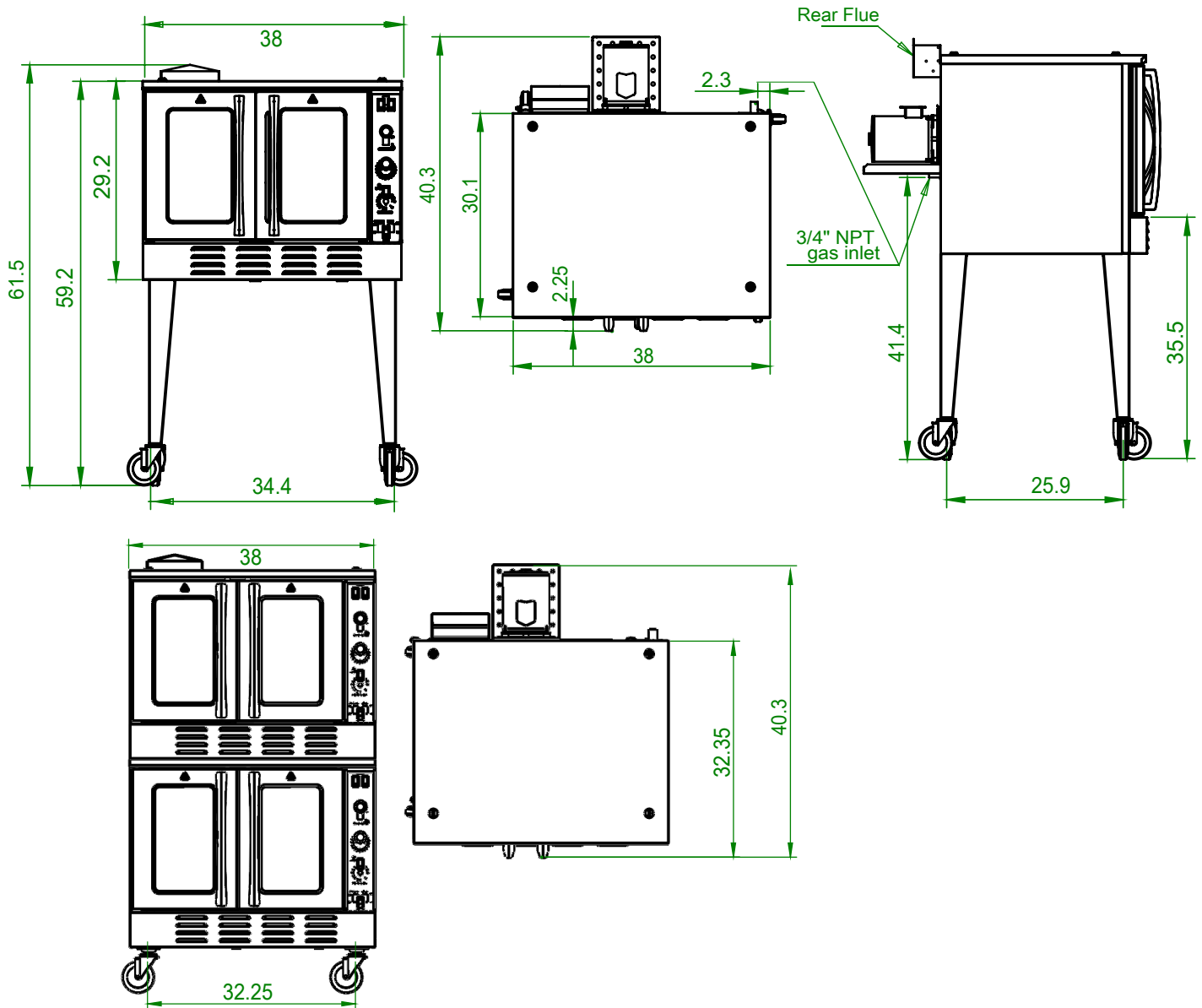

Model	Racks	External Dimensions			Internal Oven Dimensions			Total BTU's	AMP	Volts	Crated Weight (lbs)
		W	D	H	W	D	H				
CO-1-N	5	38	43.5	54.7	28.5	21.5	20	54,000	5.9	120V	605
CO-1-P	5	38	43.5	54.7	28.5	21.5	20	54,000	5.9	120V	605