

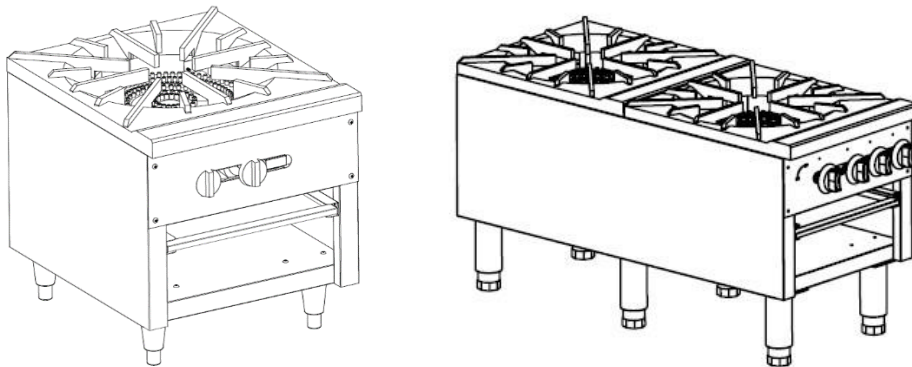

## **GAS STOCK POT RANGE**

### **Parts List**

### **SP-1, SP-2**



**Entrée LLC  
4673 OSBORNE DR., SUITE I  
EL PASO, TX 79922  
704-900-2068**

**WEBSITE:**

**[www.entree.biz](http://www.entree.biz)**

## Specifications

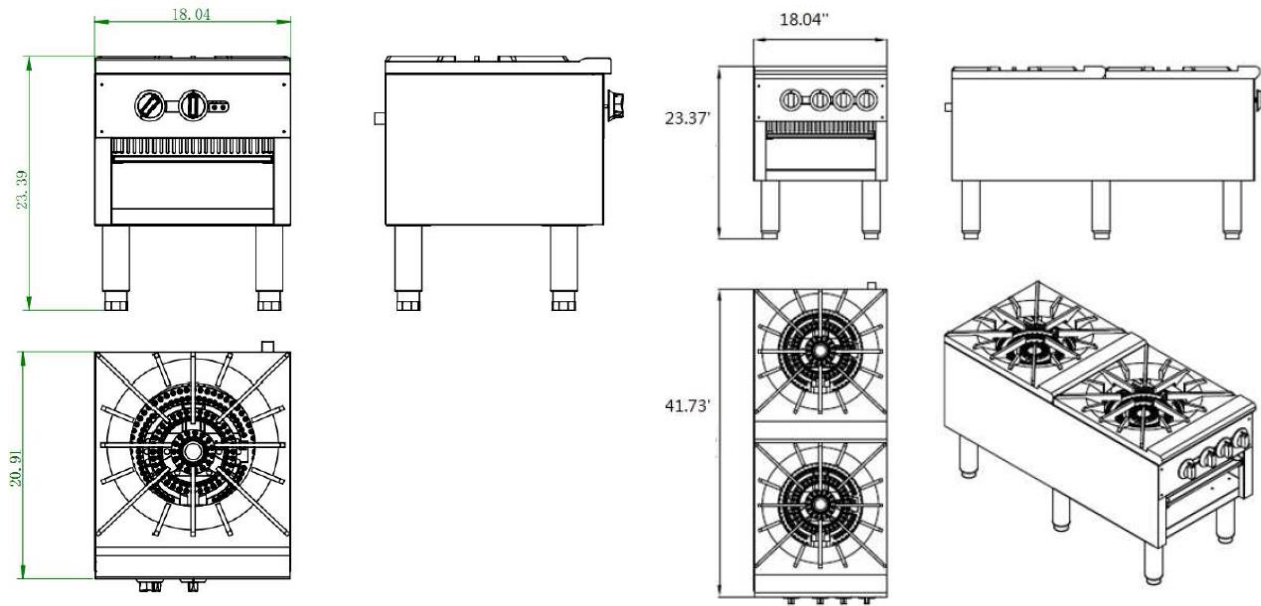

DESCRIPTION	STOCK POT RANGE	
	SP-1	SP-2
MODEL		
DIMENSIONS	18.4" W X 21"D X 23.4" H	18.4" W X 41.75"D X 23.4" H
BTU PER BURNER	40,000	40,000
# OF BURNERS	2	4
TOTAL BTU'S	80,000	160,000
OPERATING GAS PRESSURE	NATURAL	L.P.G.
	4.0" W.C.	10" W.C.
ORIFICE SIZE	#31 DMS	#52 DMS
NET WEIGHT	106 LBS	200 LBS

\*Shipped setup for Natural Gas and includes a kit for converting to LPG.



Conforms to ANSI  
Z83.11b -2009  
Certified to CSA  
STD 1.8b - 2009



Conforms to  
NSF Std. 4

# SP-1

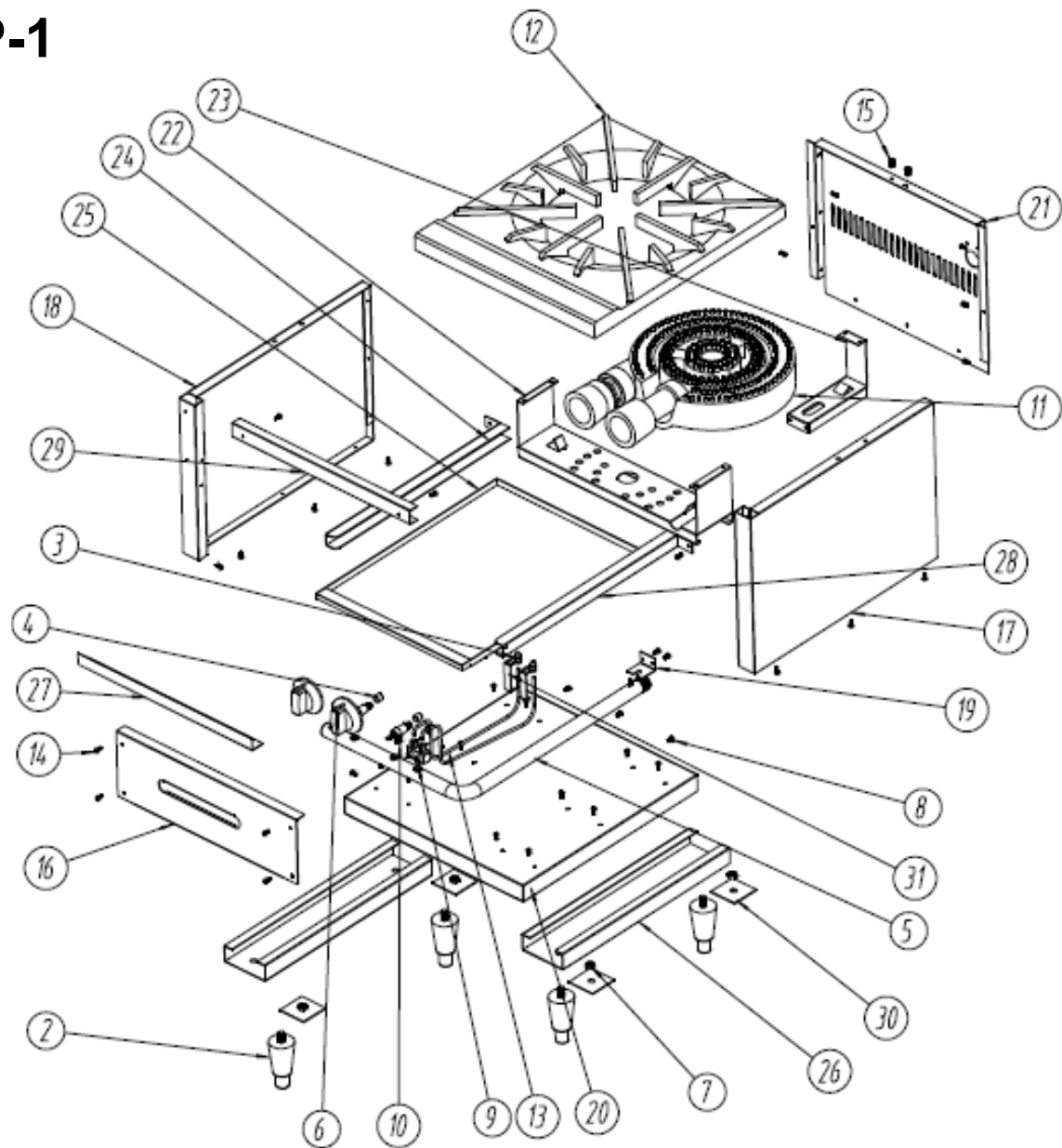

Ref #	Part #	DESCRIPTION	Qty	Ref #	Part #	DESCRIPTION	Qty
1	SP10011	BURNER GRATE	2	13	SP10017	CRUMB TRAY	1
2	NA	REAR SHROUDING	1	14	SP10010	KNOB	4
3	GC10003	PILOT	4	15	SP10018	FRONT PANEL	1
4	NA	RIGHT SHROUDING	1	16	GR10018	Adjustable valve	2
5	N/A	BASEBOARD	1	17	GC10004	GAS VALVE	4
6	NA	GAS INLET PIPE	1	18	SP10001.95	LP ORIFICE FITTING (1.95 mm)	8
7	SP10012	CONNECTOR (NOZZLE)	2	18	SP10003.15	NAT ORIFICE FITTING (3.15 mm)	8
8	SP10013	CONNECTING PIPE (BURNER)	2	19	NA	LEFT SHROUDING	1
9	SP10014	CONNECTING PIPE A (PILOT)	2	20	SP10019	CONNECTING PIPE B (PILOT)	2
10	SP10015	CONNECTOR (GAS VALVE)	2	21	NA	SUPPORTING PLATE (BURNER)	2
11	NA	GUIDE RAIL (RIGHT)	1	22	SP10020	BURNER	2
12	SP10016	ADJUSTABLE LEG	6	23	NA	GUIDE RAIL (LEFT)	1

# SP-2

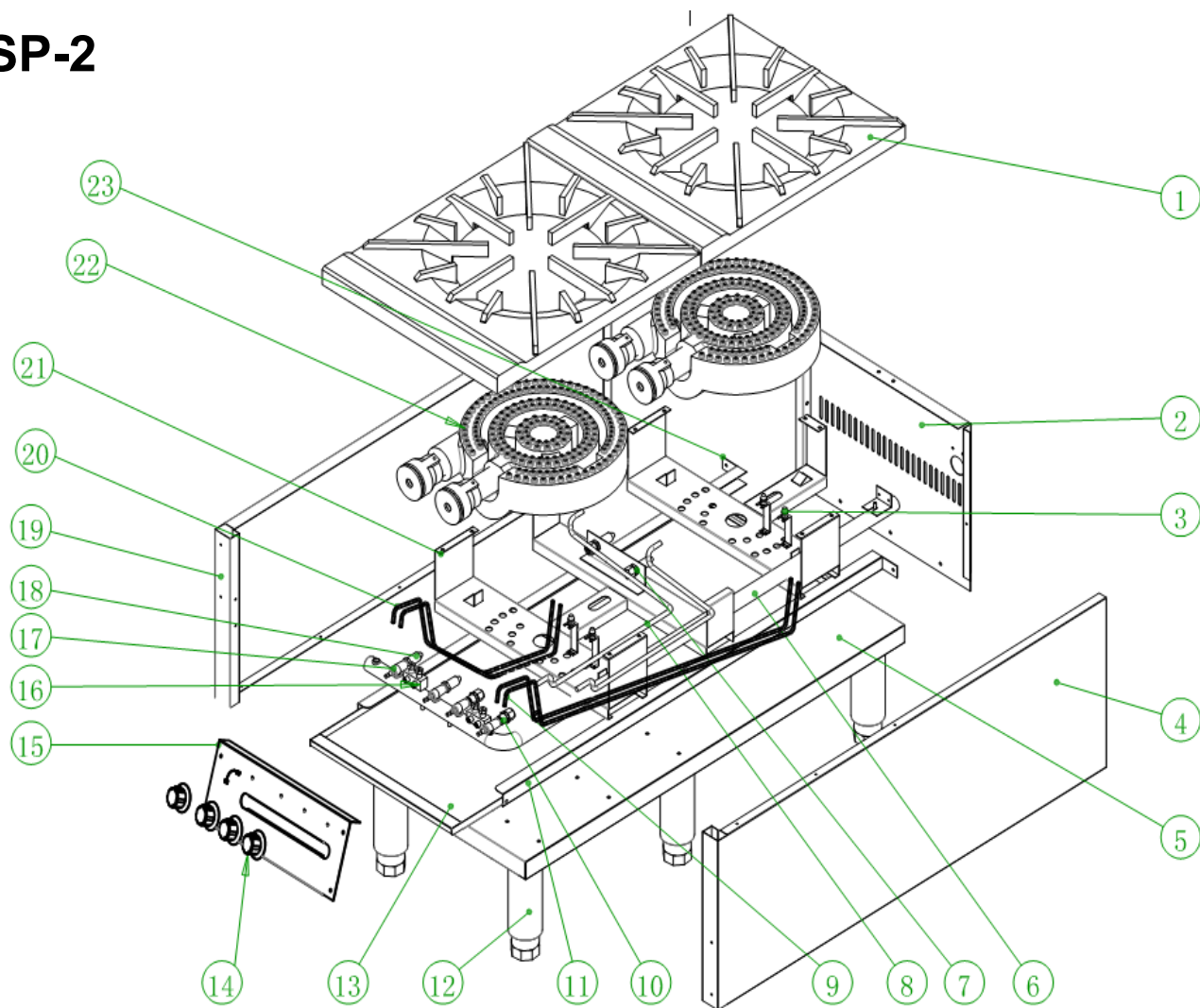

Ref #	ENTRÉE #	DESCRIPTION	Qty	Ref #	ENTRÉE #	DESCRIPTION	Qty
1	SP10010	KNOB	2	17	NA	Right cover board	1
2	GC10008	ADJUSTABLE LEG	4	18	NA	Left cover board	1
3	GC10003	PILOT	2	19	NA	Fixing plate	1
4	SP10003.15	NAT ORIFICE FITTING	2	20	N/A	Base board	1
5	NA	Gas inlet tube	1	21	N/A	Back board	1
6	NA	Testing end cap for inlet pipe	1	22	NA	Supporting plate for burner	1
7	NA	M12 nut	4	23	NA	Connecting plate	1
8	NA	M5-10 hexagonal bolt	3	24	NA	Left rail	1
9	GR10018	Adjustable valve	1	25	SP10022	CRUMB TRAY	1
10	GC10004	GAS VALVE	4	26	NA	Stiffening plate for foot	2
11	SP10020	BURNER	2	27	NA	Supporting plate for inlet tube	1
12	SP10011	BURNER GRATE	2	28	NA	Right rail	1
13	NA	Tube connecting to pilot	2	29	NA	Stiffening plate	1
14	NA	Round head screw (M4-12)	36	30	N/A	Backing plate for foot	4
15	NA	Flat head screw (M8-12)	3	31	NA	Fixing plate for pilot	2
16	SP10021	FRONT PANEL	1				



## Gas Stock Pot Range by Entrée

For Warranty Service Call (866) 417-6140

For Technical Support (570) 752-4602

ENTRÉE LLC

4673 Osborne Drive

Suite I

El Paso TX 79922

Register your warranty online at: [www.entree.biz](http://www.entree.biz)

A product with the Entrée name incorporates the best in durability and low maintenance. We all recognize, however, that replacement parts and occasional professional service may be necessary to extend the useful life of this unit. When service is needed, contact an Entrée Authorized Service Agency, or your dealer. To avoid confusion, always refer to the Model Number, Serial Number and Type of your unit.

