

# *Entrée LLC*

## *Refrigeration Products*

### *Service Manual*



## **Freezer & Refrigerators**

Installation, Specifications, Service, Electrical Diagrams, Service

Troubleshooting Guidelines, Warranty Guidelines

## *Table of Content*

Section	Page Numbers
Electrical Requirements-----	3
Wire Sizing Chart-----	4
Serial Number Information-----	5
Receiving & Inspection-----	6
Equipment Specifications-----	6 thru 11
Installation of Refrigeration Equipment-----	12 thru 13
Equipment Operating Temperatures-----	13
Defrost Section-----	14 thru 20
Temperature Controllers-----	21 thru 25
Sequence of Operation-----	25
Compressor Section-----	26 thru 31
Refrigeration Section-----	32 thru 36
Information About Polyol Ester Oil-----	37
Doors & Hardware-----	38 thru 42
Wiring Diagrams-----	43 thru 66
Warranty Guidelines-----	67 thru 70
Maintenance and Care-----	71 thru 73
Lamp Replacement on Merchandiser-----	74

## ***Electrical Requirements***

There are several electrical factors that can affect the operation of an Entrée Refrigerator or Freezer. Listed below are items that need to be checked prior to installation of your refrigeration equipment? If not checked prior to installation can cause needless service calls and voided warranty.

Entrée only uses two types of electrical plugs on their equipment. Your outlets should match

NEMA 5-15R Used on units except the 3 Door Freezers

NEMA 5-20R Used on All 3 Door Freezers

- 1- Make sure circuit is a dedicated circuit exclusively for that equipment.
- 2- No Extension Cords, Use of an extension cord **WILL VOID WARRANTY**
- 3- All electrical complies with city electrical codes
- 4- Check for proper voltage at receptacle prior to plugging in equipment.
- 5- Voltage drops must not exceed more than 10% on compressor start up.
- 6- Alteration to electrical plug or cord **WILL VOID WARRANTY**

## Wire Sizing Chart

To prevent voltage drops in the electrical power being supplied to a given Entrée unit, below is a wire size to amperage chart. To prevent voltage drops of no more than 2% wire size, length of wire run by amperage must match. Volts & Amperage is located on the label location shown page 3

This chart is for only 105 to 120 volts, as all Entrée & Centaur Plus equipment are based on 115 volts. The highest load on any Entrée Equipment would be 20 amps

Amps	Distance in feet to Center Load											
	20'	30'	40'	50'	60'	70'	80'	90'	100'	120'	140'	160'
2	14	14	14	14	14	14	14	14	14	14	14	14
3	14	14	14	14	14	14	14	14	14	14	14	12
4	14	14	14	14	14	14	14	14	14	12	12	12
5	14	14	14	14	14	14	14	12	12	12	10	10
6	14	14	14	14	14	14	12	12	12	10	10	10
7	14	14	14	14	14	12	12	12	10	10	10	8
8	14	14	14	14	12	12	12	10	10	10	8	8
9	14	14	14	12	12	12	10	10	10	8	8	8
10	14	14	14	12	12	10	10	10	10	8	8	8
12	14	14	12	12	10	10	10	8	8	8	8	6
14	14	14	12	10	10	10	8	8	8	6	6	6
16	14	12	12	10	10	8	8	8	8	6	6	6
18	14	12	10	10	8	8	8	8	6	6	6	5
20	14	12	10	10	8	8	8	6	6	6	5	5

**Warning:** Any compressor failing to start due to wire size for length of run, will not be warrantied

## ***Serial Number Information:***

The Model & Serial numbers and other information label are located on the left interior wall at eye level.



You will need this information when placing a warranty service call or for warranty parts

*Serial Numbers: The first 2 numbers are the year the second 2 numbers are the month*

*1301ENTH00000 = First two digits (13) is the year- 2013,  
Second two digits (01) is the Month -January*

**For Warranty Service, parts, tech support call 1-704-900-2068**

## ***Receiving & Inspecting The Equipment***

Even though most equipment is shipped crated, care should be taken during unloading so the equipment is not damaged when being moved.

1: Once you uncrate the equipment, inspect for hidden or concealed damages both inside & out, and also the compressor compartment.

2: If damage is found, notify to freight carrier. If possible take pictures of the damage for your records. And request an inspection by the freight carrier. This should be done immediately. Retain all crating material until inspection has been made.

### ***Refrigerants***

***All Entrée & Centaur Plus Refrigerators use R-134A Refrigerant***

***All Entrée & Centaur Plus Freezers use R-404A Refrigerant***

## ***SPECIFICATIONS For Entrée Reach-In Refrigerators & Freezers***

Model	V/Hz/PH	Amps	Capacity Cu-Ft'	Capacity Shelf Sq. Ft.	HP	BTU	Refrigerant Charge	Shipping weight LBS	NEMA Plug Type
CR1	115/60/1	6	23	14.0	3/8	3200	12 R-134A	350	5-15P
CR2	115/60/1	9	49	28.1	1/2	5800	18.7 R-134A	518	5-15P
CR3	115/60/1	10	72	42.1	3/4	7625	21.2 R134A	669	5-15P

Model	V/Hz/PH	Amps	Capacity Cu-Ft	Capacity Shelf Sq.-Ft.	HP	BTU	Refrigerant Charge	Shipping Weight LBS	NEMA Plug Type
CF1	115/60/1	9	23	14.0	5/8	2325	15.2 R-404A	364	5-15P
CF2	115/60/1	12	49	28.1	1	3650	26.6 R-404A	568	5-15P
CF3	115/60/1	17	72	42.1	1-1/4	4500	28.2 R-404A	776	5-20P

Note:

## Specifications Entrée Prep & Under Counter Refrigerator & Freezers

Model	V/Hz/PH	Amps	Capacity CU-Ft	Capacity Shelf Sq. Ft.	HP	BTU	Refrigerant Charge	Shipping Weight LBS	NEMA Plug Type
P47	115/60/1	7.5	12	16	1/2	5600	9.9 R-134A	348	5-15P
P70	115/60/1	7.5	22	34	1/2	6200	10.6 R-134A	432	5-15P
P94	115/60/1	9	32	54	3/4	6800	13.8 R-134A	582	5-15P
Model	V/Hz/PH	Amps	Capacity CU-Ft	Capacity Shelf Sq. Ft.	HP	BTU	Refrigerant Charge	Shipping Weight LBS	NEMA Plug Type
S29	115/60/1	5	7	14	3/8	3200	9.5 R-134A	276	5-15P
S48	115/60/1	7	12	26	1/2	5400	9.5 R-134A	313	5-15P
S61	115/60/1	7	15.5	30	1/2	5800	10.6 R-134A	362	5-15P
S29-MT	115/60/1	5	7	14	3/8	3200	9.5 R-134A	276	5-15P
S48-MT	115/60/1	7	12	26	1/2	5400	9.5 R-134A	313	5-15P
S61-MT	115/60/1	7	15.5	30	1/2	5800	10.6 R-134A	362	5-15P

Model	V/Hz/PH	Amps	Capacity CU-Ft	Capacity Shelf Sq. Ft.	HP	BTU	Refrigerant Charge	Shipping Weight LBS	NEMA Plug Type
UR27	115/60/1	5	6.5	14	3/8	2800	9.5 R-134A	243	5-15P
UR48	115/60/1	5	12	26	3/8	3000	9.5 R-134A	300	5-15P
UR61	115/60/1	5	15.5	30	3/8	3200	10.6 R-134A	348	5-15P
WTR27	115/60/1	5	6.5	14	3/8	2800	9.5 R-134A	243	5-15P
WTR48	115/60/1	5	12	26	3/8	3000	9.5 R-134A	300	5-15P
WTR61	115/60/1	5	15.5	30	3/8	3200	10.6 R-134A	348	5-15P

Model	V/Hz/PH	Amps	Capacity CU-Ft	Capacity Shelf Sq. Ft.	HP	BTU	Refrigerant Charge	Shipping Weight LBS	NEMA Plug Type
UF27	115/60/1	7	6.5	14	1/2	3500	12.3 R-4-04A	243	5-15P
UF48	115/60/1	9	12	26	1/2	3800	14.5 R-404A	300	5-15P
UF61	115/60/1	10	15.5	30	5/8	4200	15.2 R-404A	348	5-15P
WTF27	115/60/1	7	6.5	14	1/2	3500	12.3 R-404A	243	5-15P
WTF48	115/60/1	9	12	26	1/2	3800	14.5 R-4044A	300	5-15P
WTF61	115/60/1	10	15.5	30	5/8	4200	15.2 R-4044A	348	5-15P

Note:

## Specifications for Centaur Plus Reach-in Refrigerators & Freezers Top Mount

Top Mount Units Meaning: The condensing unit (compressor) is located on top of the cabinet. The benefit to this is the condenser stays cleaner as it is not near floor traffic.

1- The drawback is the air is warmer closer to the top of a room and the customer is not able to stack things on top of the cabinet.

2- Customer should be **WARNED** when purchasing a Top Mount unit that nothing can be stacked on top of the cabinet.

SOLID DOOR REFRIGERATORS									
MODEL#	V/Hz/Ph	AMPS	STORAGE CAPACITY Cu-ft	SHELF CAPACITY Sq-ft	HP	BTU	CHARGE OZ	SHIP WEIGHT LBS	NEMA PLUG
CSD-1DR-TSI	115/60/1	6	23	14.0	3/8	3200	12.0	350	5-15P
CSD-2DR-TSI	115/60/1	9	49	28.1	1/2	5800	18.7	518	5-15P
CSD-3DR-TSI	115/60/1	10	72	42.1	3/4	7625	21.2	669	5-15P

SOLID DOOR FREEZERS									
MODEL#	V/Hz/Ph	AMPS	STORAGE CAPACITY Cu-ft	SHELF CAPACITY Sq-ft	HP	BTU	CHARGE OZ	SHIP WEIGHT LBS	NEMA PLUG
CSD-1DF-TSI	115/60/1	11	23	14.0	5/8	2325	14.1	364	5-15P
CSD-2DF-TSI	115/60/1	12	49	28.1	1	3650	25	568	5-15P
CSD-3DF-TSI	115/60/1	16	72	42.1	1-1/4	4500	28.9	776	5-20P

Notes:



## Specification for Centaur Plus Refrigerators & Freezers – Bottom Mount

**Bottom Mount Units Meaning:** The condensing unit (compressor) is located underneath the cabinet. The benefit to this is the air intake for the condenser is located near the floor where the intake air for the condenser is cooler. The condenser coil is easier accessed for cleaning and service.

The drawback to Bottom Mount unit is the air intake to the condenser is more susceptible to dirty & lint being drawn on to the condenser surface.

***WARNING:*** All Condenser should be check and cleaned every 30 Days

SOLID DOOR REFRIGERATORS									
MODEL#	V/Hz/Ph	AMPS	STORAGE CAPACITY Cu-ft	SHELF CAPACITY Sq-ft	HP	BTU	CHARGE OZ	SHIP WEIGHT LBS	NEMA PLUG
CSD-1DR-BAL	115/60/1	6	23	14.0	3/8	3200	12.0	350	5-15P
CSD-2DR-BAL	115/60/1	9	49	28.1	1/2	5800	18.7	518	5-15P
CSD-3DR-BAL	115/60/1	10	72	42.1	3/4	7625	21.2	669	5-15P

SOLID DOOR FREEZERS									
MODEL#	V/Hz/Ph	AMPS	STORAGE CAPACITY Cu-ft	SHELF CAPACITY Sq-ft	HP	BTU	CHARGE OZ	SHIP WEIGHT LBS	NEMA PLUG
CSD-1DF-BAL	115/60/1	11	23	14.0	5/8	2325	14.1	364	5-15P
CSD-2DF-BAL	115/60/1	12	49	28.1	1	3650	25	568	5-15P
CSD-3DF-BAL	115/60/1	16	72	42.1	1-1/4	4500	28.9	776	5-20P

**Note:**

## Specifications for Centaur Plus Prep & Under Counter Refrigerators & Freezers

PIZZA PREP TABLES										
MODEL #	V/Hz/Ph	AMPS	STORAGE CAPACITY Cu-ft	PAN 1/3 Size	SHELF CAPACITY Sq-ft	HP	BTU	CHARGE OZ	SHIP WEIGHT LBS	NEMA PLUG
CPR-44	115/60/1	7	12	6	16	1/2	5600	9.9	348	5-15P
CPR-67	115/60/1	7.5	22	9	34	1/2	6200	10.6	432	5-15P
CPR-93	115/60/1	9	32	12	54	3/4	6800	13.8	582	5-15P

SANDWICH/SALAD UNITS										
MODEL #	V/Hz/Ph	AMPS	STORAGE CAPACITY Cu-ft	PAN 1/6 Size	SHELF CAPACITY Sq-ft	HP	BTU	CHARGE OZ	SHIP WEIGHT LBS	NEMA PLUG
CST-28	115/60/1	5	7	8	14	3/8	3200	9.5	276	5-15P
CST-48	115/60/1	7	12	12	26	1/2	5400	9.5	313	5-15P
CST-60	115/60/1	7.5	15.5	16	30	1/2	5800	10.6	362	5-15P

UNDERCOUNTER & WORKTOP REFRIGERATORS										
MODEL #	V/Hz/Ph	AMPS	STORAGE CAPACITY Cu-ft	SHELF CAPACITY Sq-ft	HP	BTU	CHARGE OZ	SHIP WEIGHT LBS	NEMA PLUG	
CUR & CWR-28	115/60/1	5	6.5	14	3/8	2800	9.5	243	5-15P	
CUR & CWR-48	115/60/1	5	12	26	3/8	3000	9.5	300	5-15P	
CUR & CWR-60	115/60/1	5	15.5	30	3/8	3200	10.6	348	5-15P	

UNDERCOUNTER & WORKTOP FREEZERS										
MODEL #	V/Hz/Ph	AMPS	STORAGE CAPACITY Cu-ft	SHELF CAPACITY Sq-ft	HP	BTU	CHARGE OZ	SHIP WEIGHT LBS	NEMA PLUG	
CUF & CWF-28	115/60/1	7	6.5	14	1/2	3500	12.3	291	5-15P	
CUF & CWF-48	115/60/1	9	12	26	1/2	3800	13.4	340	5-15P	
CUF & CWF-60	115/60/1	10	15.5	30	5/8	4200	14.1	388	5-15P	

## Specifications for Centaur Plus Glass Door Refrigerators & Freezers

### Swing Door Refrigerators

Model	V/Hz/PH	AMPS	Capacity CU.-FT.	HP	BTU	Refrigerant & Charge OZ	Shipping Weight	NEMA Plug Type
CGD-1DR-12	115/60/1	6	12	3/8	2800	12 R-134A	254	5-15P
CGD-1DR-16	115/60/1	6	16	3/8	3000	12 R-134A	282	5-15P
CGD-1DR-23	115/60/1	6	23	3/8	3200	12 R-134A	331	5-15P
CGD-2DR-48	115/60/1	7	48	1/2	5800	18.7 R-134A	540	5-15P
CGD-3DR-70	115/60/1	10	72	3/4	7625	21.2 R-134A	741	5-15P

### Swing Door Freezers

Model	V/Hz/PH	AMPS	Capacity CU.-FT.	HP	BTU	Refrigerant & Charge OZ	Shipping Weight	NEMA Plug Type
CSD-1DF-12	115/60/1	11	12	3/8	2325	10.6 R-404A	258	5-15P
CGD-1DF-16	115/60/1	11	16	5/8	2800	11.3 R-404A	289	5-15P
CGD-1DF-23	115/60/1	11	23	5/8	3000	14.1 R-404A	353	5-15P
CGD-2DF-48	115/60/1	12	48	1	3650	25.0 R-404A	567	5-15P
CGD-3DF-70	115/60/1	16	72	1 1/4	4500	28.9 R-404A	829	5-20P

Model	V/Hz/PH	AMPS	Capacity CU.-FT.	HP	BTU	Refrigerant & Charge OZ	Shipping Weight LBS	NEMA Plug Type
CGD-2DR-47	115/60/1	7	47	1/2	5800	18.7 R-134A	540	5-15P

## ***Installation of all Refrigeration Products***

### ***Location:***

Units represented in this manual are intended for indoor use only. Be sure the location chosen has a floor strong enough to support the loaded weight of the cabinet and its contents. A fully loaded cabinet can weight can be as high as 1500 pounds. Reinforce floor as necessary to provide for maximum weight. For the most efficient operation of the refrigeration system be sure to provide good air circulation inside and out. Check specification sheet for unloaded weights

### ***Inside The Cabinet:***

Do not pack the cabinet in such a way to prevent good air circulation. This is important to provide good heat recovery from all the product and prevent freeze ups or damage to the compressor. This will also cause overflow of evaporator drain pans and loss of temperature. The shelves are wire type to allow good air circulation through the product. DO NOT cover shelves with any type of covering such as aluminum foil. Boxes or packages should be placed in such a way to allow air flow through them. DO NOT stack package or boxes against the interior back wall, as this will stop air flow or against the intake air inlet to the evaporator coil.

### ***Outside The Cabinet:***

Cabinet should have access to ample fresh air. ALL Cabinets should be at least 2 inches off any interior wall to prevent re-circulation of hot air into the condenser coil.

If the unit is not provided with proper air circulation to the condenser coil, an increase in temperature will occur. This could also cause damage to the compressor and refrigeration system.

### ***Leveling:***

A level cabinet looks better and will perform better because the doors will be aligned properly. Improperly leveled cabinet can cause condensate water to overflow either the evaporator or condensate drain pans.

Use a level to properly level you refrigeration unit, to ensure proper operation of the cabinet.

### *Stabilizing:*

All models are supplied with casters for your convenience, ease of cleaning underneath and for mobility. It is very important, however, that the cabinet be installed in a stable condition with the front wheels locked while in use. Should it become necessary to lay the unit on its side or back for any reason, allow at least 24 hours before start-up so as to allow compressor oil to flow back to the sump. Failure to meet these requirements can cause compressor failure and unit damage.

Laying a cabinet on its side or back can also cause the motor mounting springs inside the compressor to come off. This will cause the compressor to make a banging sound at start up or shut down.

**Warning: Unit repairs will not be subject to standard unit warranties due to improper installation procedures.**

**Warning: The unit should always be disconnected or unplugged when performing any kind of service or maintenance.**

### *Operating Temperatures:*

#### *Refrigerators*

All Entrée products refrigerators have a set point setting of 34 degrees F, At 34 degree the compressor will cycle off. The refrigerator has a differential setting of 4 degrees F. The refrigerator will cycle the compressor back on when the temperature rises to 38 degrees. This should maintain a product temperature of approximately 35 degrees continually.

#### *Freezers*

All Entrée products freezers have a set point setting of -7 degrees F. At -7 degrees the compressor will cycle off. The freezer has a differential setting of 4 degrees F. The freezer cycle the compressor back on when the temperature rises to -3 degrees. This should a product temperature of approximately -5 degrees continually.

## ***Defrost Section***

### **Refrigerator**

**Defrost Frequency:** 6 hours from the time power is first applied to the cabinet the first defrost will occur and every 6 hours of continual use. If power is interrupted by a short power outage this will cause the unit to restart its count and the unit will go into defrost 6 hours after power is restored.

This could cause the unit to miss a defrost cycle, and could cause a freeze up of the defrost coil. You can place the unit into a manual defrost by pressing the snow flake to the left of the "set" button on the controller and hold down for 4 seconds.

**Defrost Duration:** Maximum of 20 minutes factory setting or when the evaporator probe reaches a temperature of 41 degrees F. or whichever comes first.

### **Freezer**

**Defrost Frequency:** Defrost Frequency: 6 hours from the time power is first applied to the cabinet the first defrost will occur and every 6 hours of continual use. If power is interrupted by a short power outage this will cause the unit to restart its count and the unit will go into defrost 6 hours after power is restored.

This could cause the unit to miss a defrost cycle, and could cause a freeze up of the defrost coil. You can place the unit into a manual defrost by pressing the snow flake to the left of the "set" button on the controller and hold down for 4 seconds.

**Defrost Duration:** Maximum of 20 minutes factory setting or when the evaporator probe reaches a temperature of 45 degrees F. or whichever comes first.

Defrost is controlled by the controller and can be changed by going into the parameters. This is not recommended, but can be change to fit the volume of the use of the refrigerator or freezer. The number of times the door is opened is the volume of the use.

**NOTE:** More about defrost is cover in the Controller Section

## Drain Tube Heater

Note: All Entrée & Centaur Plus have drain tube heaters that operates only during the defrost cycle. The drain tube heater part number H00211 is used on all freezers, and it is 115v at 13 watts and approximately .007 Amps

## Defrost Heater Amperage per Model

**Note:** None of the refrigerator models in either Entrée or Centaur Plus have defrosts heaters. All refrigerators are off cycle defrost, the compressor is turned off a maximum of 20 minutes.

All Entrée & Centaur Plus Freezers have electric defrost heaters, listed below is the amperage for each model.

### Entrée Reach-ins

Model	Volts and Watts	Total Defrost Amps	Part number
CF1	115 V at 550 watts	4.85	H00201
CF2	115 V at 800 watts	7.03	H00202
CF3	115 V at 1100 watts	9.63	H00203

### Entrée Under Counters & Worktops

Model	Volts and Watts	Total Defrost Amps	Part Number
UF27 & WTF27	115 V at 335 watts	2.98	H01201
UF48 & WTF48	115 V at 463 watts	4.09	H01202
UF61 & WTF61	115 V at 464 watts	4.10	H02201

### Centaur Plus Bottom Mount Freezers

Model	Volts and Watts	Total Defrost Amps	Part Number
CSD-1DF-BAL	115 V at 550 watts	4.85	H00201
CSD-2DF-BAL	115 V at 800 watts	7.03	H00202
CSD-3DF-BAL	115 V at 110 watts	9.63	H00203

## Centaur Plus Top Mount Freezers

Model	Volts and Watts	Total Defrost Amps	Part Number
CSD-1DF-TSI	115 V at 550 watts	4.85	H00201
CSD-2DF-TSI	115 V at 800 watts	7.03	H00202
CSD-3DF-TSI	115 V at 110 watts	9.63	H00203

## Centaur Plus Undercounter & Worktop

Model	Volts and Watts	Total Defrost Amps	Part Number
CUF27 & CWF27	115 V at 335 watts	2.98	H01201
CUF48 & CWF48	115 V at 463 watts	4.09	H01202
CUF61 & CWF61	115 V at 464 watts	4.10	H02201

### ***Troubleshooting Defrost Related Problems:***

How to Initiate a Manual Defrost: Push the snowflake to the left of the set button and hold down for 4 seconds to activate a defrost cycle.

***Note: A freezer temperature must be below 20 degrees F. for it activate a defrost cycle. A refrigerator must be below 38 degrees F. to activate a defrost cycle.***



After 4 seconds the compressor and interior fan motors should shut off and the LED light under the snowflake with droplets should light up.



## Once unit is in defrost:

**Step 1-** If the unit is a 2 door or 3 door reach-in there will be a defrost contactor located behind the shroud the controller is mounted on. To open shroud, remove screws above the doors, the top of the shroud is hinged so the shroud can be swung up to give you easy access to wiring & components.

**Step 2-** Identify the defrost contactor; it will be the contactor that is energized. If neither contactor is energized, then go to the # 7 terminal on the controller, with a volt meter check voltage to a neutral (white) wire.

A- No voltage, controller is bad replace it.

B- If you have voltage at #7, then check voltage at the defrost contactor coil, if you have voltage to the coil, but the contactor is not energized the contactor coil is open, replace the contactor.

C- If the contactor is energized check the terminals across the contactor, no voltage reading the contactor is closed. If you get a voltage reading the contactor terminals are open, replace the contactor.

D- If you determine the contactor is good, place an Amp Meter cross the terminal or load side terminal. If you get an amp reading check one of the charts to match the model number in defrost amp section of this book to determine if it correct.

E- No amp reading, then either you have an open defrost heater, an open thermal cutoff or a loose connector.

F- Pictured below is the Thermal Cutoff, it should be bypassed to determined that the defrost & drain tube heaters are both okay



G- If defrost heater and drain tube heater test okay, replace thermal cutoff

Defrost continued;

Note: The same procedure above will apply as a troubleshooting guide for the single door reach-in and the Undercounter & Worktop Freezer. There is no defrost contactor on the single door reach-in or the undercounter or worktop units. Defrost circuit to defrost heaters comes directly off the #7 terminal of the controller.

Defrost Heater: Is located underneath the evaporator coil.

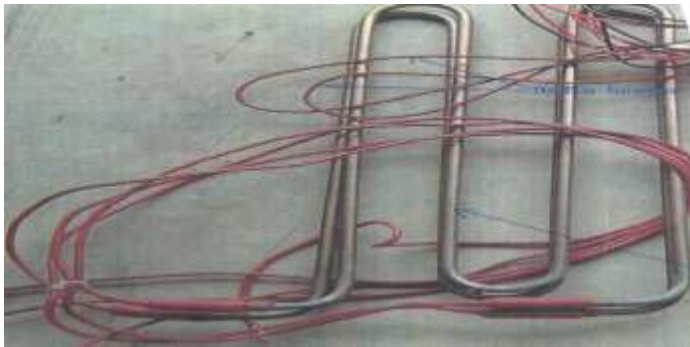

### Step 3- Changing Defrost Settings

Note: Changing the defrost setting will not always cure the evaporator freeze up problem. Be sure steps 1 & 2 have been accomplished prior to making any changes in the defrost settings. They should only be changed when the unit is in a high volume kitchen or high humidity area. If it is determined a change must be done to the settings:

A- The controller controls all defrost settings.



## Defrost Continued:

B- To get into the parameters see instructions on the picture above. Once "HY" appears release both the down arrow & set buttons, then push and release "set" only to go through the parameters.

## C-The Defrost Parameters:

Parameter code	Description	Default Setting	Maximum Setting
dtE	Defrost Termination Temp	45	52
idF	Intervals between Defrost	6	4
MdF	Minutes of the Defrost	20	30

### *Causes of Evaporator Freeze Ups for Freezer:*

1- Thermal Cutoff open – Defrost Heaters will not operate in the defrost cycle if the thermal cutoff is open.

2- Defrost Heater Open- Have voltage at the defrost heater wires, but no amp draw. Determine with an Ohm meter if heater has an open circuit.

3- Failed Defrost Contactor- Either open coil or contacts

4- Failed Controller- open contactor at terminal #7 on controller

5- Failed Drain Tube Heater- This will cause the drain to freeze up stopping the flow of condensate water during defrost cycle.

6- Clogged Drain- Trash or left over particles from manufacturing can clog drain  
7-Poor air circulation inside the cabinet.

8- Door left ajar

9- Failed Evaporator Fan Motors- No air moving across the evaporator coil to gain heat.

10- Bad door switch (only on the Centaur Plus Units) this will keep the evaporator fan motors from operating.

11- Loose or burnt wire connectors-

12- Dirty evaporator coil- No air movement through the evaporator coil.

Defrost continued;

13- Evaporator Fan Blade loose or on backward

14- Bad Door Gaskets

### ***Causes of Evaporator Freeze Ups for Refrigerators:***

Note: Refrigerators do not use defrost heaters or contactors; they are strictly turn off the compressor for up to 20 minutes.

1- Low Refrigerant Charge- If the unit cannot reach set point setting of 34 degrees F. The P2 evaporator sensor will not allow the unit to go into a defrost cycle. The will never reach the 34 degree set point. The unit runs continually until it freezes up.

2- Dirty condenser or poor air circulation around the condenser. The results will be as described as in step 1.

3- Clogged drain

4- Failed controller: Will not go into manual defrost even with the temperature at 34 degrees.

5- Bad evaporator fan motor

6- Evaporator fan blade is loose or on backward.

7- On Sandwich / Salad or Pizza Prep units the condiment pans have to be in place on the rails to keep warm air from entering the unit. If they are left out overnight or long periods of time or don't fit properly on the rails, this can also cause an evaporator freeze up. Make sure all pans set completely down on the rail to make a good seal.

8- Bad Door Gaskets

9- The Controller's set point is set to cold. Set point on refrigerators should never be set below 33 degree F.

Notes:

## Controllers

Note: Listed below are the specifications for the Dixell Controllers. Entrée only uses the Dixell XR20C for Refrigerator units and the XR60C for the Freezer units.

Sometimes you may receive a Dixel XR02CX as a replacement for the refrigerators. The parameters will be the same as the XR20C.

Set Point – Is the temperature the compressor will cycle off

Differential – Added to the Set Point is the temperature the compressor will cycle back on.

Example: Refrigerator factory Set Point 34 degree F. plus 4 degree differential = 38 degree F

**ALL REPLACEMENT CONTROLLERS ARE PRE-PROGRAMMED AND A "HOT KEY" IS NOT NECESSARY.**



### Trouble Shooting Tips for Controller:

1- Do you have a temperature reading on the controller. If no then you have no power to the controller. Check the power switch, power cord and breaker.

2- Controller has a temperature reading, but nothing is running. Are any of the LEDS lite up.

a- Check set point setting, Freezers should be at -7 degrees and refrigerators at 34 degrees.

b- If set points are correct, check output voltage to fans & compressor. No output voltage, replace controller.

## Alarm Display:

**P1** is flashing on the controller. This is an indication of failure in the thermostat probe located near the intake air of the evaporator. To resolve this failure:

1- Inspect for a loose connection at the controller on terminal 11 or 12.

2- Inspect that it is wired properly as this happens often when replacing the controller.

3- Inspect for cut or nicks in the probe wire.

4- If all the above check okay, replace probe

**P2**- is flashing on the controller. This is an indication of failure in the evaporator probe located on the front side of the evaporator coil. To resolve this failure:

1- Inspect for a loose connection at the controller on terminal 10 or 11.

2- Inspect that it is wired properly as this happens often when replacing the controller.

3- Inspect for cuts or nicks in the probe

wire. 4- If all the above checks okay, replace

probe

Both P1 & P2 are flashing on the controller. This will occur, but rarely.

1- Inspect all wire connections of 9, 10, 11& 12 terminals.

Note: The "11" terminal is the common terminal for all probes.

2- Best advise if you are getting an indication of failure on all probes

Replace the controller and probes

**P3-** is flashing on the controller. This is an indication of failure in the condenser probe located on the compressor discharge line at the condenser coil. Use the same steps as for P1-P2 probes, except the terminals will be 9 & 11. **Note: The P3 probe is not used on all units, only those with only one condenser fan motor.**

**CSd-** is flashing on the controller. This is an indication of high compressor discharge temperatures.

1- The condenser coil is clogged with trash or dirt. Clean

2- The condenser fan motor has failed. Replace

3- Bad air circulation, inspect the location of the unit and determine if it is getting the proper air flow to the condenser coil. All cabinet should be at least 2" off any interior wall. Units are not designed to operate in ambient temperature **above 95 degrees F.**

Controller Alarms continued:

**HA** – is flashing on the controller. This is an indication the unit has reached the high temperature alarm setting, and has remained there for more than 90 minutes.

This could be caused by several conditions. Inspect the unit this may require putting refrigeration gauges on the system.

**LA-** is flashing on the controller. This is an indication the unit has reached the low temperature alarm setting, and remained there for more than 90 minutes.

This could be cause by several conditions, such as a bad controller or stuck contactor.

**Warning:** Prior to changing any parameters on the controller, you need to check with Entrée Technical Support, by changing any setting can change the set up of the engineering design.

## Controller Terminals:



Refrigerator Controller Terminals



Freezer Controller Terminals

## Location of Contactors and Terminal Boards

Located behind upper shroud



Notes:



## Dixell Specification:



**Do not throw items into the storage area.**  
Failure to heed these recommendations could result in damage to the interior of the cabinet.

### Refrigeration cycle

**Refrigerators:** During the refrigeration cycle, the evaporator fans will run continuously even when one or more doors are open. The door switch will activate the lights when opened.

1. Every 6 hours, the unit will be off and let the evaporator coil clear up the ice, the controller now display defrost symbol. When the coil temperature reach 41° F or after 20 minutes, the unit start to work again.
2. Anti-condensation heaters on door frames work in conjunction with the compressor.
3. The factory setting for temperature range is 34° to 38° F

**Freezers:** During the refrigeration cycle the controller supplies power to the condensing unit and evaporator fan motors. The evaporator fans will run at any time when the evaporator coil temperature is below 35° F, they will also keep running during door openings but cycle off during a defrost period. The door switch will activate the lights when opened.

1. Every 6 hours, the unit will be off and electric heater will be on to clear up the ice, the controller now display defrost symbol. When the coil temperature reach 45° F or after 20 minutes, the unit start to work again.
2. Anti-condensation heaters on door frames work in conjunction with the compressor.
3. The factory setting for temperature range is -7° to -3° F

### On/Off Switch:

An on/off switch is located on the front of the top shroud. When the unit is on, the switch will glow green.

### SOLID-STATE THERMOSTAT DESCRIPTIONS:

#### 1. FRONT PANEL COMMANDS



**SET:** To display target set point; in programming mode it selects a parameter or confirm an operation.

**DEF (DEF)** To start a manual defrost

**▲ (UP):** To see the last temperature alarm happened; in programming mode it browses the parameter codes or increases the displayed value.

**▼ (DOWN)** To see the last temperature alarm happened; in programming mode it browses the parameter codes or decreases the displayed value.

#### KEY COMBINATIONS:

**▲ + ▼** To lock & unlock the keyboard.

**SET + ▼** To enter in programming mode.

**SET + ▲** To return to the room temperature display.

#### 1.1 USE OF LEDS

Each LED function is described in the following table.

LED	MODE	FUNCTION
*	ON	Compressor enabled
*	Flashing	- Programming Phase (flashing with *) - Anti-short cycle delay enabled
*	ON	Defrost enabled
*	Flashing	- Programming Phase (flashing with *) - Drip time in progress
✪	ON	Fans enabled
✪	Flashing	Fans delay after defrost in progress.
⚠	ON	An temperature alarm happened

#### 2. MAIN FUNCTIONS

##### 2.1 HOW TO SEE THE SETPOINT

1. Push and immediately release the **SET** key; the display will show the Set point value;
2. Push and immediately release the **SET** key or wait for 5 seconds to display the probe value again.

##### 2.2 HOW TO CHANGE THE SETPOINT

1. Push the **SET** key for more than 2 seconds to change the Set point value;
2. The value of the set point will be displayed and the \* LED starts blinking;
3. To change the Set value push the ▲ or ▼ arrows within 10s.
4. To memorise the new set point value push the **SET** key again or wait 10s.

##### 2.3 HOW TO START A MANUAL DEFROST

1. Push the **DEF** key for more than 2 seconds and a manual defrost will start.

##### 2.4 HOW TO LOCK THE KEYBOARD



1. Keep pressed for more than 3 s the UP and DOWN keys.
2. The "POF" message will be displayed and the keyboard will be locked. At this point it will be possible only to see the set point or the MAX o Min temperature stored
3. If a key is pressed more than 3s the "POF" message will be displayed.

##### 2.5 TO UNLOCK THE KEYBOARD

Keep pressed together for more than 3s the ▲ and ▼ keys, till the "Pon" message will be displayed.

#### 3. ALARM SIGNALS

Message	Cause	Outputs
"P1"	Room probe failure	Compressor output according to par. "Con" and "COF"
"P2"	Evaporator probe failure	Defrost end is timed
"P3"	Condenser probe failure	Outputs unchanged.
"HA"	Maximum temperature alarm	Outputs unchanged.
"LA"	Minimum temperature alarm	Outputs unchanged.
"dA"	Door open	Compressor and fans restarts
"EA"	External alarm	Output unchanged.
"CA"	Serious external alarm (1F=bAL)	All outputs OFF.
"CSD"	Condenser alarm	All outputs OFF.

##### 3.1 HOW TO SEE THE ALARM AND RESET THE RECORDED ALARM

1. Push the UP or Down key, the alarm signals are displayed.
2. When the signal is displayed, hold the SET key until the "rst" message is displayed, and push the SET again, the "rst" message starts blinking and the normal temperature will be displayed.

## ***Compressor Troubleshooting Section***

### **Quick Check Reference:**

A) Compressor not operating:

1) Is the compressor extremely hot?

a) If the compressor is not operating and the condenser fans are operating, Compressor is extreme hot, the compressor is off on the overload.

b) Is the condenser coil clean? You should be able to see light through the condenser coil.

c) Compressor tries to start but trips overload.

1) What is the amp draw at the common terminal?

2) What is the startup voltage at the common & run compressor terminals.

3) Have you checked for burnt wire connection?

4) Have you tried a hard start kit, Start Cord or Compressor analyzer?

B) Compressor is cool to touch & not operating, condenser fan is operating

1) Have you checked voltage at the compressor terminals?

2) Have you taken Ohm readings across the terminals?

3) Checked for burnt or loose connections?

C) Neither compressor or condenser fan motor operated. Compressor is cool to touch.

1) Checked voltage at the compressor contactor coil?

Continued on the next page

## Compressor Trouble shooting continued

Contactor & Terminal locate behind shroud in right hand picture



Compressor Contactor



Upper shroud is hinged

a) Is the controller giving a digital reading? Is the snow flake lite up at the top of the temperature readings?

b) If no power go to back of the controller and check power on the compressor terminal. Terminal # 5 for refrigerators and terminal #3 for freezers

c) Checked voltage at the terminal board terminals that feed power to the condensing unit.

Compressor Troubleshooting continued:

d) Loose wire or connector

D) Compressor Operating, but no cooling

a) Is the condenser clean?

b) Is the compressor discharge line hot or cool?

c) Is there any heat on condenser coil?

d) Is the drier or cap tube sweating?

e) Is the evaporator coil iced up?

# Embraco Aspera Compressors for Entrée & Centaur Plus

Typical Compressor wiring diagrams

For the models of Embraco/Aspera compressor used for Entrée / Centaur Plus

## SM 04 NB/NE SERIES CSIR Cord Anchorage & Start Device - American Version

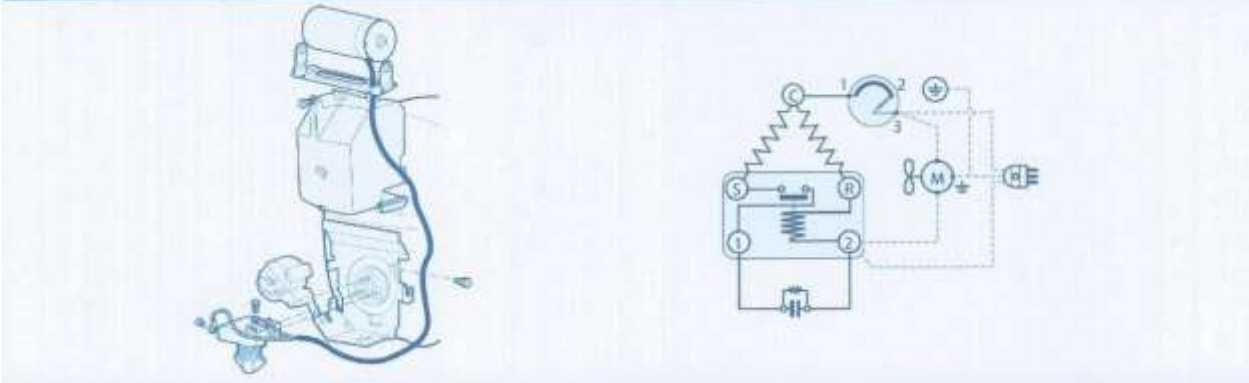

## SM 16 NJ SERIES CSR Box (Internal Overload Protector)

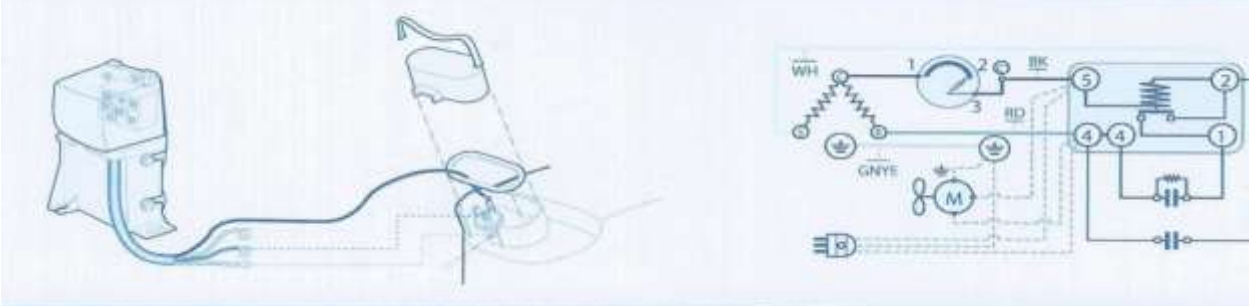

## SM 13 T SERIES CSR Box (Internal Overload Protector)

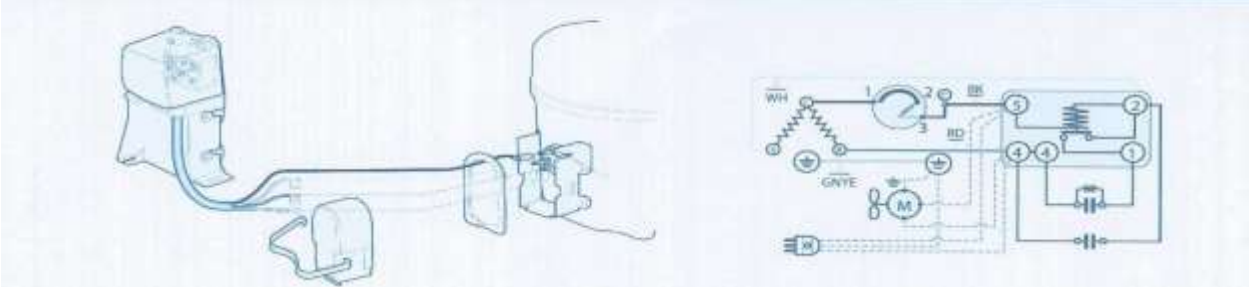

Compressors continued:

The Potential Start Relay:

The potential (voltage sensing) start relay places the starting capacitor in series with the start windings. It does so by sensing voltage across the start winding, rather than line current as does the current relay.

The contacts of the potential relay are normally closed and the start capacitor is connected to the start winding as soon as power is applied to the compressor motor. The relay's coil senses the voltage dropped across the start winding. It is designed to pick up, open its contacts, and disconnect the start capacitor from the start winding, **WHEN SUFFICIENT VOLTAGE IS GENERATED**. Since the voltage or back-EMF generated by the start winding is proportional to the motor speed, the relay will open only when the motor has started and is approaching normal running speed.

EMF= Electromotive Force

**This is why it is very important to have units with larger compressor such as 3 door freezers being supplied with sufficient voltage and no voltage drops at the compressor terminals. Any voltage drop at the compressor of more than 10% will cause continual circuit breaker trips.**

The Current Relay

Current Starting Relays are used on the smaller compressor motors. The current relay contacts are normal open when de-energized, unlike the potential relay with closed contacts. Current relay its coil is wound with heavy wire and is placed in series with the incoming power line. The connections to the current relay are L, M, and S alternate connections are 1, 5, and 2. When the compressor is energized in –rush currents pass through the current relay coil, its contacts close and connect the start winding to the motor circuit. The start winding is wound with a higher resistance than the run winding, this changes its phase current with respect to the run windings, and produces the torque requires for the motor to start. The relays contacts open when current drops as the compressor comes up to speed, and the start windings is disconnected from the motor circuit.

**A current or potential relays can be tested with an Ohm meter for open or closed contacts or open coils.**

Compressors continued

## Most Common Compressor Failures:

***Locked Up or Seized Motors:*** What is the Locked Rotor Amps (LRA), check nameplate LRA to see if they match. This can only be tested with an Amp meter on the Common or Run terminals. Cause is normally by loss of good lubricating oils, liquid refrigerant flood back or high discharge temperatures. Refrigerant oils, high discharge temperatures and flood back are covered in the refrigeration section.

***Open Windings:*** This can only be tested with a good Ohm meter.

Causes of open windings are normally caused by spot burns in either the start or run windings and the breakdown of the motor insulation.

***Shorts to Ground:*** Can be tested with a good Ohm meter, by checking each terminal to the compressor case or copper lines attached to the compressor.

Listed below is the most common cause of open windings or burnt compressors

1- Mis-wired

2- Solid contaminants in the refrigeration system

3- High acid in the refrigeration, due to previously poor clean ups of the refrigeration system.

4- Operating out of

specification 5- Loss of

lubrication

6- Flood backs causing liquid refrigerant to be in crankcase

7- High discharge temperatures and inadequate sub-cooling for the compressor motor

8- Short cycling

9- Failed starting components

Compressors continued;

***Inefficient or Non pumping Compressor*** : Can only be determine with the installation of refrigerant gauges on both the high side and low side of the system. This cannot be determined by Amperage.

Determining if a compressor is inefficient, normally with both gauges on the system, the system is operating at low head pressure, high suction and low amperage. Sometimes when the compressor is turned off the suction line will get hot quickly.

Most common cause:

1- Poor maintenance: Condenser coil is dirty or clogged, condensers coils should be cleaned at every 60 days.

2- Liquid Refrigerant Flood Back: Evaporator freezes ups is one of the most common cause of liquid flood back, due to no heat gain to boil off refrigerant. Over charging with refrigerant is a very common failure with a capillary system, all refrigerant charges should be weighted in to the factory name plate spec. Refrigerator or freezer doors are open for long periods, keeping the evaporator fan motors from operating.

***Internal Noise:*** Compressors are not designed to be laid on their side or turned upside down. A hermetic compressor has internal mounting springs, which can come off the mountings when this occurs. When this occurs the compressor will make a banging sound at start up or shut down.

Liquid refrigerant is the other thing that can cause a compressor to be noisy.

***A well trained refrigeration technician should take time to investigate the cause of compressor failures. Often this is not done, causing repeated callbacks they expect the customer or manufacture to pay. Make it right the first time.***

Notes:

## Refrigeration Section

All of the Entrée & Centaur Plus Refrigeration Systems are capillary type systems, as in the refrigeration diagram below.

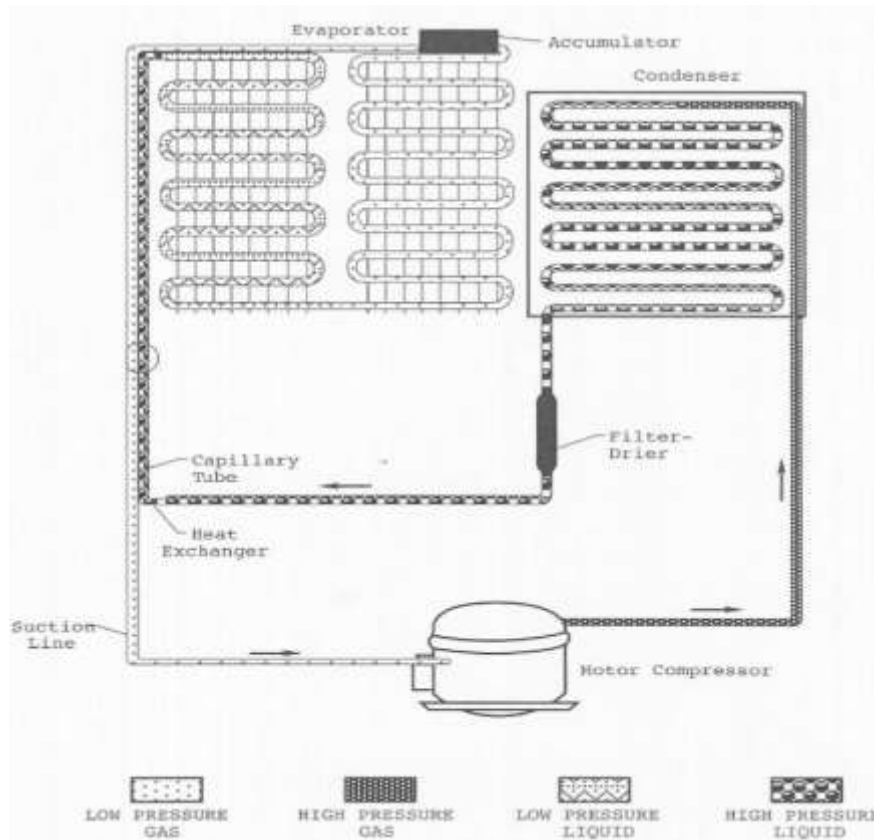

### THE CAPILLARY TUBE REFRIGERATION SYSTEM

Basics how a capillary system operates:

Starting at the motor compressor the refrigerant from a low pressure gas is compressed to a high pressure gas and pumped into the condenser. In the condenser with the condenser fan motor circulating air over the refrigerant inside the condenser coil, the refrigerant is condensed from a high pressure gas to a high pressure liquid. The high pressure liquid then leaves the condenser and enters the drier, which is designed to remove moisture & contaminants that maybe in the system. Liquid refrigerant enters the capillary tube, the pressure is reduced as it enters the evaporator coil, the liquid refrigerant starts to boil as heat is picked up in the evaporator and the refrigerant changes to a low pressure gas. The low pressure gas enters the accumulator to boil off any liquid refrigerant prior to returning to the compressor through the suction line.



Refrigeration continued:

### The Capillary Tube:

The capillary tube is probably the simplest of all metering devices. The capillary tube is commonly used as a metering device used on self-contained refrigerators and freezers. It is constructed of a single tube with inside diameter in the range of .026 to .090 inches. It is between the drier & the evaporator coil, and a large portion of it maybe coiled either at the evaporator or in the condensing unit section. See picture to the below, most generally the capillary tube is either soldered or foil taped to the suction line to create a heat exchanger. The size of the cap tube and the length are carefully selected to match the pumping capacity of the compressor, saturation of the evaporator and sub-cooling to the compressor motor

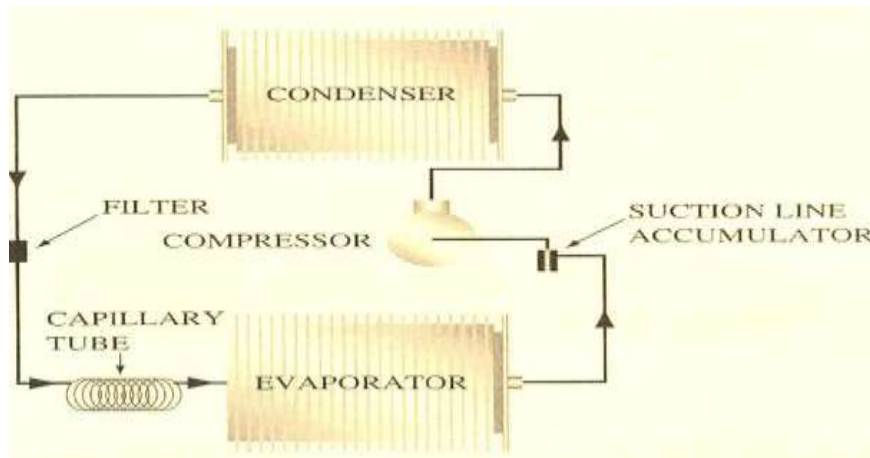

Advantages of a capillary tube system are no mechanical parts to fail and the pressure equalize quickly after the compressor shut down.

Disadvantages of a capillary system are they can become plugged due the size of the inside diameter. The evaporator can be filled with liquid when the compressor is shut down. Some manufactures install liquid line solenoids in the liquid line to prevent this from occurring.

With today's refrigerants & polyester oils being used with capillary tubes it is very important not to operate a system with high discharge temperatures above 250 degrees, as POE oil start to become gummy at approximately 275 degrees. This will cause the drier to get plugged and a breakdown of the desiccant beads. If you inspect a restricted capillary lined with WHITE POWDER inside, this has occurred.

Refrigeration continued:

Causes of High Discharge Temperature:

High discharge temperature is when the temperature at the discharge valve inside the reach temperature high enough to do damage to the system.

1- Dirty or clogged condenser coil is the most common, poor maintenance by the owner of the equipment.

2- System operating with no or low refrigerant charge, this will cause the overheating of the compressor motor by no sub-cooling at the compressor.

3- Restricted capillary tube or kinked suction line will cause the same results as previous note in low refrigerant.

***Testing:*** Remember a refrigeration system has 2 sides. When testing for restriction or low refrigerant charge, always install both the refrigerant high side & low side gauges. You can add 4 ounces of refrigerant to the system to check if both pressures increase. If the unit has some refrigerant in the system, cover up the front of the condenser coil, as the high side pressure starts to increase the low side pressure should also start to increase, if the unit is low of charge. If the unit is restricted, you'll not see an increase in pressure from the low side, and only a slight increase on the high side. *A sweating drier or capillary tube is good indication of a restriction.*

***Testing for Leaks:*** Once you have determined the unit is low of refrigerant. The unit definitely has a refrigerant leak, systems are not shipped out low of refrigerant. You can add a blend of nitrogen & refrigerant to the system, and increase the pressure up to 175 PSI. Pressure above 175 can do damage to the system. Using a (sniffer type) leak detector go over the system thoroughly. None of the Entrée products line sets are inside the foamed walls and all are accessible. But remember the foam will set off a leak detector. Once a leak is located and repaired (if repairable) replace the drier, vacuum to 200 microns, test to see if vacuum holds, recharge the system to the factory specs.

***The drier capacity is equal to 032 drier.***

## Refrigeration continued

**Warning:** Do not install only low side gauges and start adding refrigerant to the system, as this can do damage to the compressor. And never add liquid refrigerant to the low side, this will damage the low side reed valves in the compressor. Always use good refrigeration practices.

4- Oil Logged Evaporators: This is something that rarely happens on small systems. If you do encounter this failure, place the system into a prolonged defrost, or heat the evaporator up with a hot air gun. This will warm the refrigerant oil to increase the viscosity of the oil and allow it to return once the compressor starts up. If this fails to remedy the problem, then the evaporator and accumulator will have to be removed and drained of the oil and then purged with nitrogen. *Remember to fill a cup with the drained oil and add that amount back into the compressor.*

### ***Good Refrigeration Practices:***

Being a good refrigeration technician is being a good investigator. We in technical support may ask you many questions. We are not questioning your abilities as tech, but investigating to find a remedy to the problem. We in tech support are only as good as the technician on the end of the phone line.

A good technician will find the cause of the problem, and remedy the problem to eliminate it from happening again.

Before going into any refrigeration system, remember that POE oil is very hydroscopic and absorbs moisture. *Never leave a system open to the atmosphere for more than 15 minutes.* Always make sure you have every tool, etc. required to do the job prior to opening a system. Prior to going into a system a technician can tell a lot by feel. Feeling of the side of the condenser can tell if any heat is present and starting at the top and running your hand top to bottom will tell you if you are condensing refrigerant or moving refrigerant. Feeling of the suction line at the compressor will tell the tech if there is sub-cooling at the compressor or if ice is present. If ice is present at the suction line at the compressor, you are not gaining heat from the evaporator coil. Look at your drier and capillary tube in the condensing section, is there sweating present. These are simple test prior to tapping into a system. Tapping into a system is the last thing a tech should do. Entrée will not kill a warranty if you tap into a system after all these things have been tested.

## Refrigeration continued

If you tap into a system, always tap into both the high & low sides. There are ¼" processing tubes on both sides. *Never call tech support to ask for refrigeration help without having both readings, as we cannot help. We'll only ask you to go back to get both.*

Once you have tapped into the refrigeration system. For testing purposes refer back to testing earlier in this refrigeration section.

### ***Replacing Refrigeration Components:***

*Never heat up or unsolder a drier when removing it from the system, this releases contaminants into the system. Cut it out with tubing cutters. Inspect the drier for gummy oil buildup or broken down desiccant beads.*

Prior to installing a new refrigeration component into a system, it is our recommendation the system is flushed, either by nitrogen a designated flush.

If the system has a burn out on the compressor windings, an acid test is good means to test the refrigerant oil. Acid in the system is a compressor failure waiting to happen. You can acquire an acid test kit from any local refrigeration supply.

A clean refrigeration system is system that will work properly with no return calls.

Notes:

## *Polyol Ester Oil:*

After 20 years of using this lubricant in the refrigeration system, it has not improved.

HFC refrigerants require the use of POE oil for all Entrée compressors. This is necessary for two specific reasons. First, mineral oils are not readily miscible in HFCs. When using HFCs mineral oils will not return to the compressor. Secondly, the chlorine contained in CFCs and HCFCs aids in the lubricity of the mineral oil.

POE oil has its drawbacks, first it is hygroscopic, moisture rapidly builds in this oil when left to the atmosphere. Fifteen minutes is the longest any system should be left open. Once moisture is mixed with the POE oil it is impossible to remove. Drain the compressor crankcase, flush the system and install a new drier. Even this may not be enough. Second, POE oil breaks down at high discharge temperatures, causing it to become gummy. This will cause restrictions in the drier and metering device. Once this occurs it is almost impossible to remove. Again drain the compressor crankcase by pouring it into a measuring cup, add fresh oil to the crankcase. Flush the system with a good flush that is purchased from your local refrigeration supply. Replace the drier. Cleaning up a system is very important when using POE oils. It is not as forgiving as mineral oils.

Notes:

## ***Doors & Hardware***

### ***Casters:***

There are only two size of casters used on Entrée refrigeration products. All casters are of the platform type. Below is the bolt holes pattern, at 2 3/8" centers.



a- The H01316 is used on all the salad/sandwich and under counter units. This is a 2.5 inch wheel, which will increase the cabinet height approximately 3.5 inches

b- The H00316 is used on all reach-in and pizza prep units. This is a 4" wheel, which will increase the cabinet height approximately 5.5 inches.

Entrée does not at this time provide caster shims to level the cabinet.

Legs are not available for any of the Entrée or Centaur Plus units at this time.

Notes:

## ***Door Gasket Replacement***

There should be no tools required to replace a door gasket on any of the Entrée or Centaur Plus Refrigeration units.

The door gaskets backside has a dart with a barbed end. The dart inserts into a plastic groove on the inside of the door. The barbed end holds the gasket in place.

To remove the old gasket is very simple as show in the picture below. Garb the old gasket and pullout until enough of the gasket is out to place your hand under it, you can pull out the reminder of the old gasket.



Installing the new gasket by start in the upper corner and pressing the dart into the groove on the inside of the door, then across the top, down each side and across the bottom.

Note: Some gaskets have been rolled up for storage in the parts bins. They maybe twisted and difficult to work with. These storage memories in the rubber gasket can be taken out by place the gaskets in hot water for a few minute. Once the new gasket has been installed, check to make sure it is sealing good against the cabinet. If an area is not sealing good, warm that area up with a hair dryer and light pull out on the gasket at the same time, this will allow the magnet then to seal against the cabinet.

Once the gasket has been installed a few days, re-check that no frost or sweating is on the inside of the door or face of the cabinet. No frost or sweating means you have a good seal.

Doors and Hardware continued:

Pictured (picture 1) below on the left is part of the hinge assemblies mounted to the door. Both inserted into a square openings in the top and bottom of the door.

The longer of the two is called the hinge cartridge. The hinge cartridge has the spring inside which makes the door self-closing. When replacing this component always preload the spring by place a wrench on the square stub and turning it the direction the door closes until resistance from the spring is met. This will ensure the door to work properly after it is back on the cabinet.

The other part is the carrier for the Axis Hinge Pin. It is mounted to either the top or bottom of the door depending on the application.

Pictured ( picture 2) below on the right is a picture of the Axis Hinge Pin bracket new style, which is used on most all of the Entrée and Centaur Plus units.



Picture 1



Picture 2

***Note: Door replacement parts are available for all Entrée, Centaur Plus and Centaur Plus Glass Door Merchandisers.***



Doors and Hardware continued:

Pictured (picture 3) below is the old style Axis Hinge Pin, this was used on Entrée units only prior to 2010. These can still be ordered under part number H00327A. The new style are pictured in picture number 2 on the previous page.



Picture 3

When replacing these old style Axis hinge pins, always use liquid lock tight on the threads to keep the nut from backing off.

Note: You cannot replace the old style hinge pin (H00327A) with the new style H00327).

### ***Centaur Plus Doors***

There is no replacement handle available at this time, the entire door must be replaced.

## ***Glass Door Replacement & Adjustments***

Centaur Plus Glass Doors, there no replacement glass insert available door will need to be replaced.

### **Swing Door Replacement and Adjustment**

1. Open the bottom shroud and support the door weight. Loosen bottom hinge's screws and remove the door
2. Prepare new door. Insert door top pin into top hinge. Insert the bottom hinge onto the door's bottom hinge and secure to the frame
3. Allow the door to freely swing, make sure it swings close by itself with no restriction
4. Plug the unit in and make sure the lock is in the right location. Exercise the lock to ensure the cam engagement
5. If not, adjust the door until proper lock cam engagement

### **Slide Door Replacement and Adjustment**

1. Remove the hook of counterweight on the top of the door
2. Lift the door up until its bottom edge over the channel. Slide it out and down away from the cabinet.
3. Reverse the procedures to install new door

### **Remove the shroud**

1. Open the door/s.
2. Loosen and remove the top screws
3. Slide the shroud up and out of their keyhole shape slots

### **Light Bulb Replacement**

1. Top display light bulb replacement: Loose the screws in the bottom of top shroud, swing the top shroud up until it is hold by the top of the cabinet, now light bulb can be replaced;
2. Interior light bulb replacement: Open door and remove the cover. Twist and remove the bulb.

# Wiring Diagrams

**Entrée**

Reach-in Refrigerator; CR1, CR2, CR3

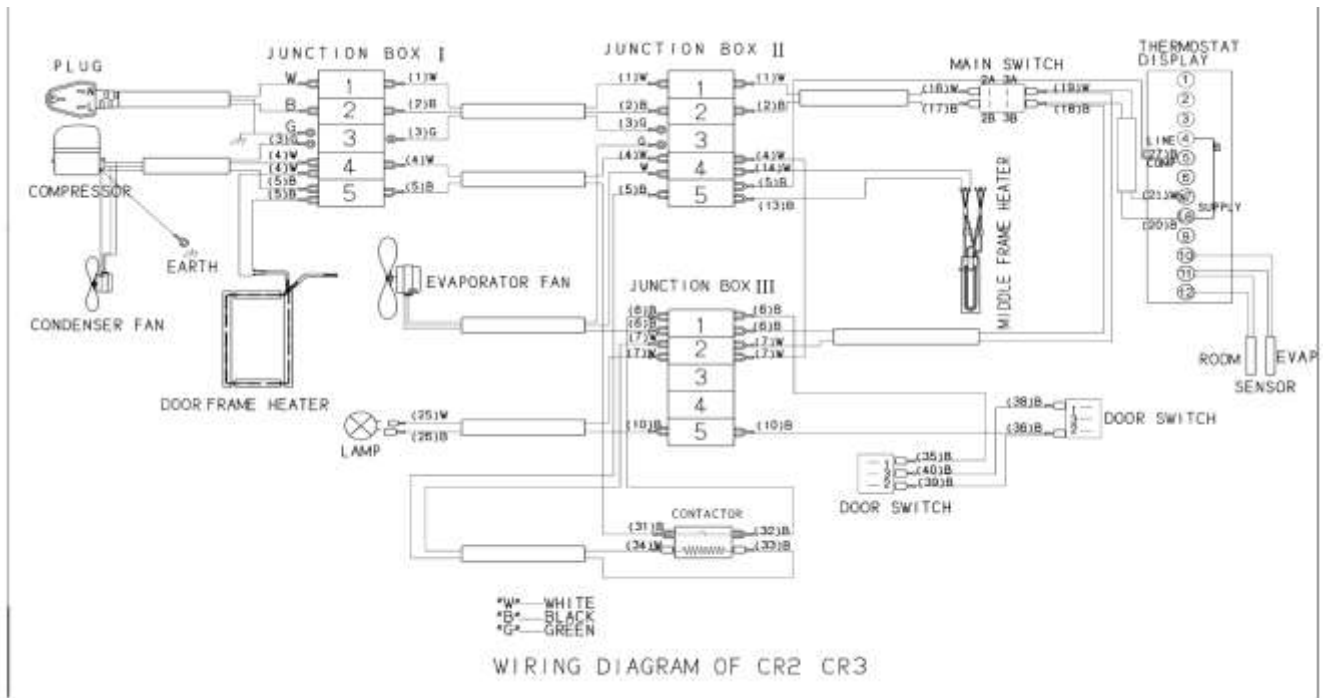
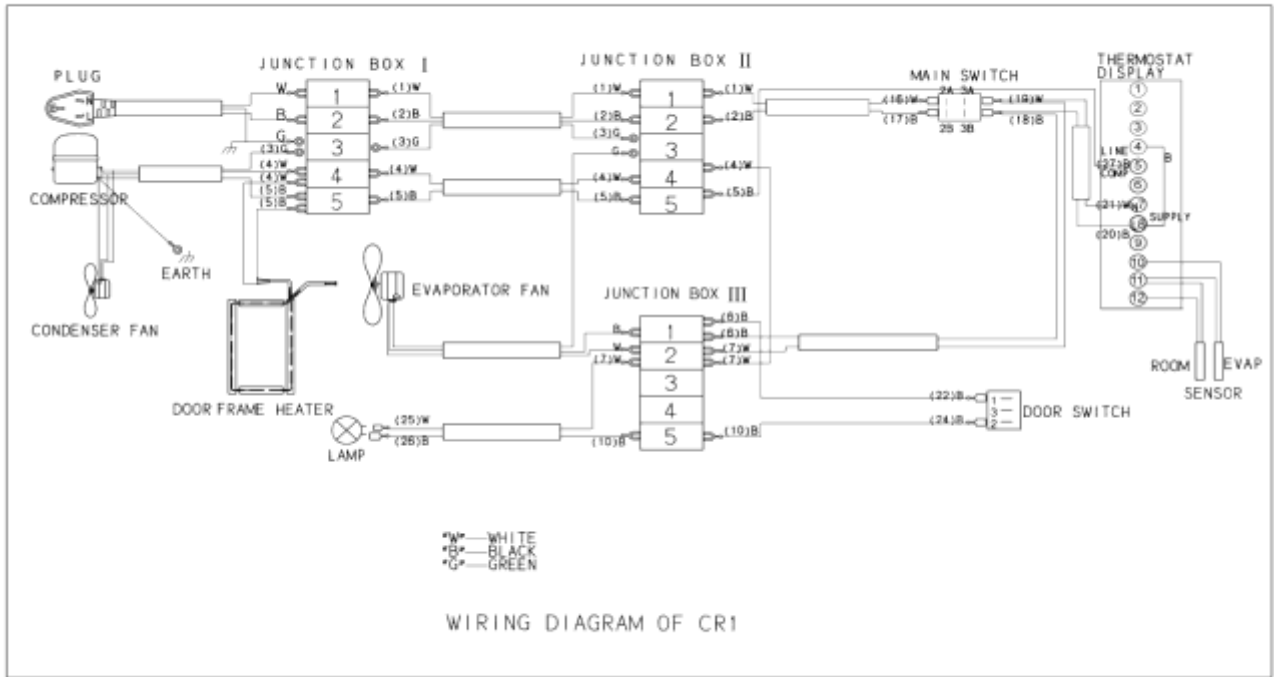

## Freezers Wiring Diagrams; CF1, CF2, CF3

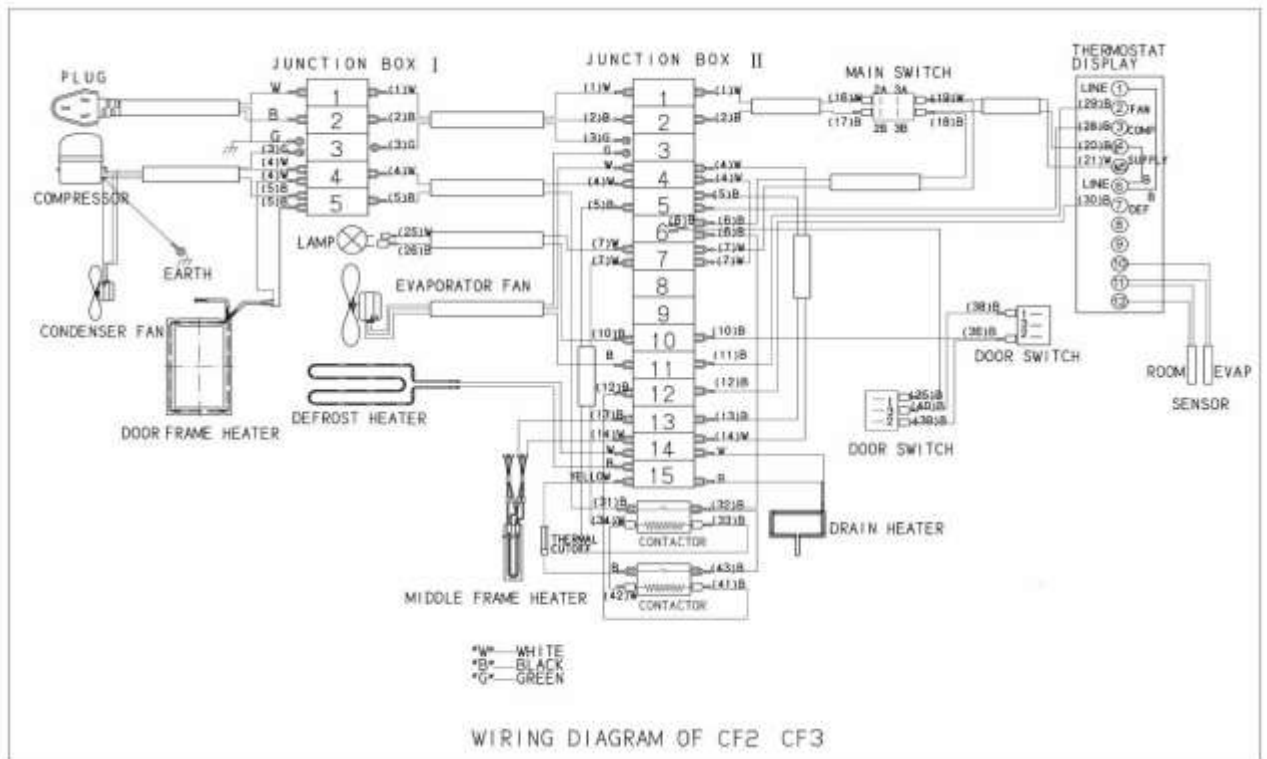
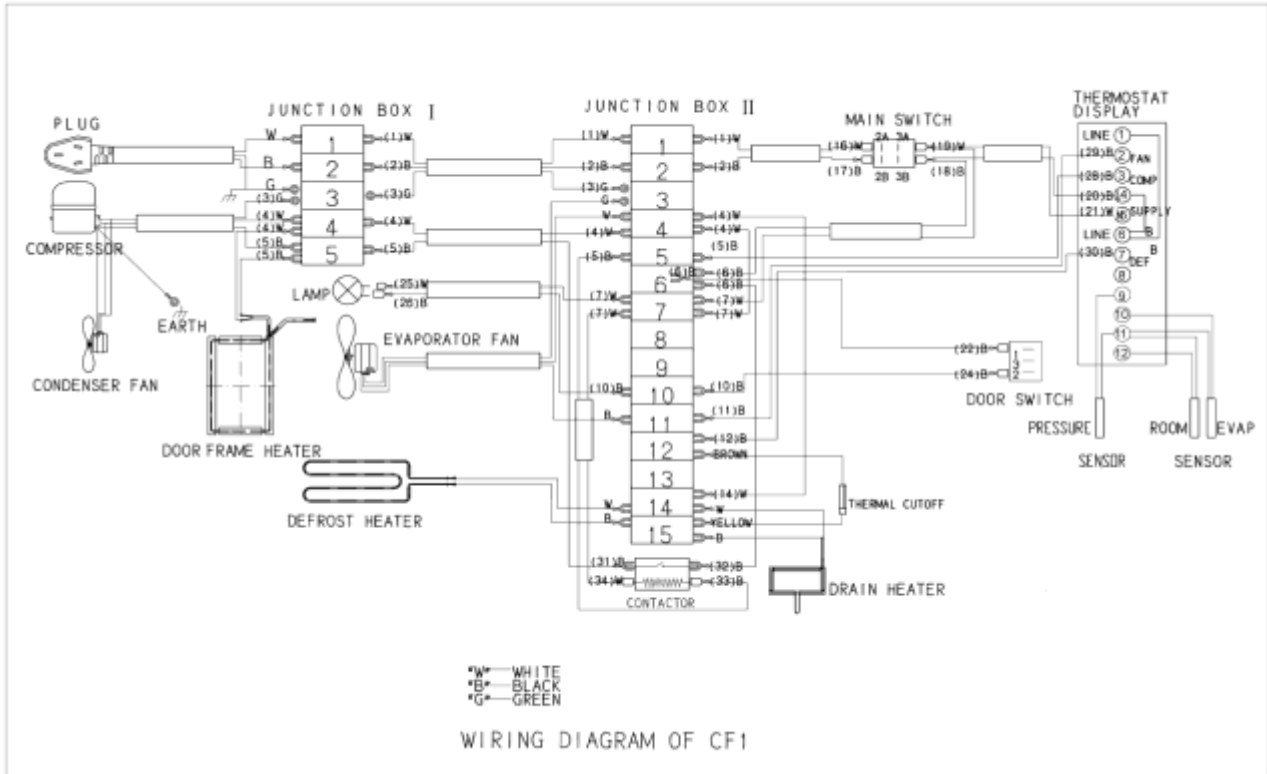

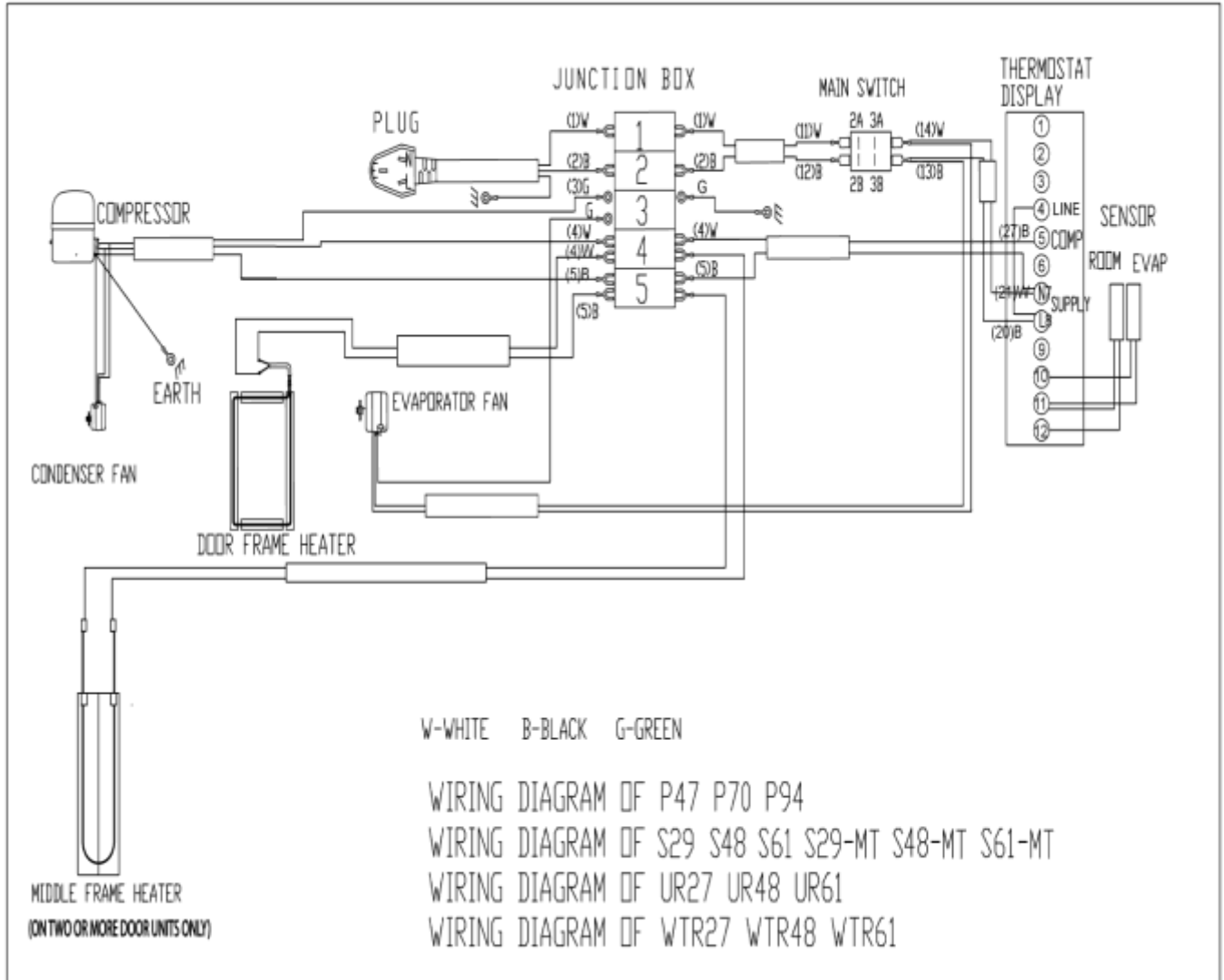

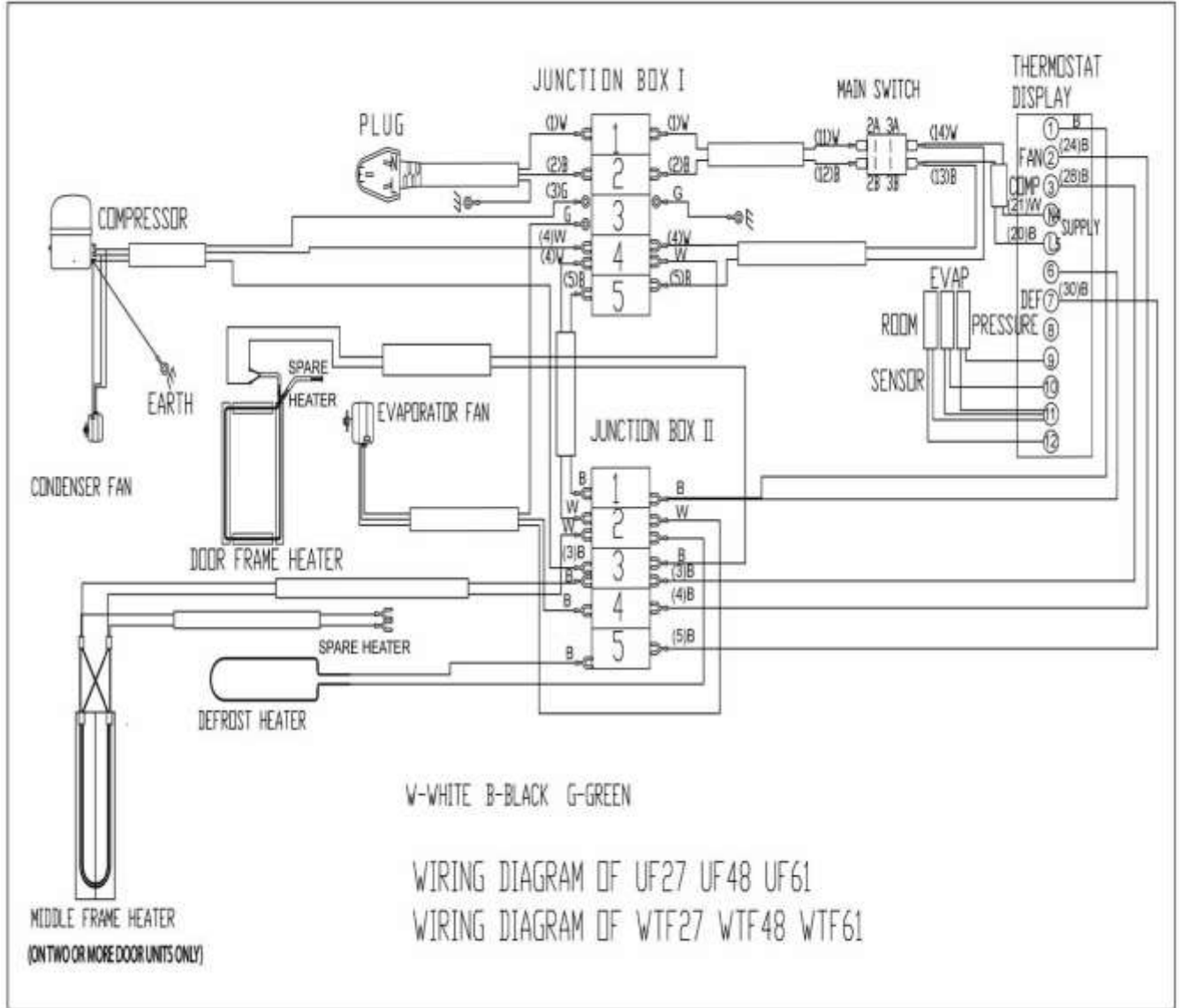

Centaur Plus Bottom Mount One Door Refrigerators

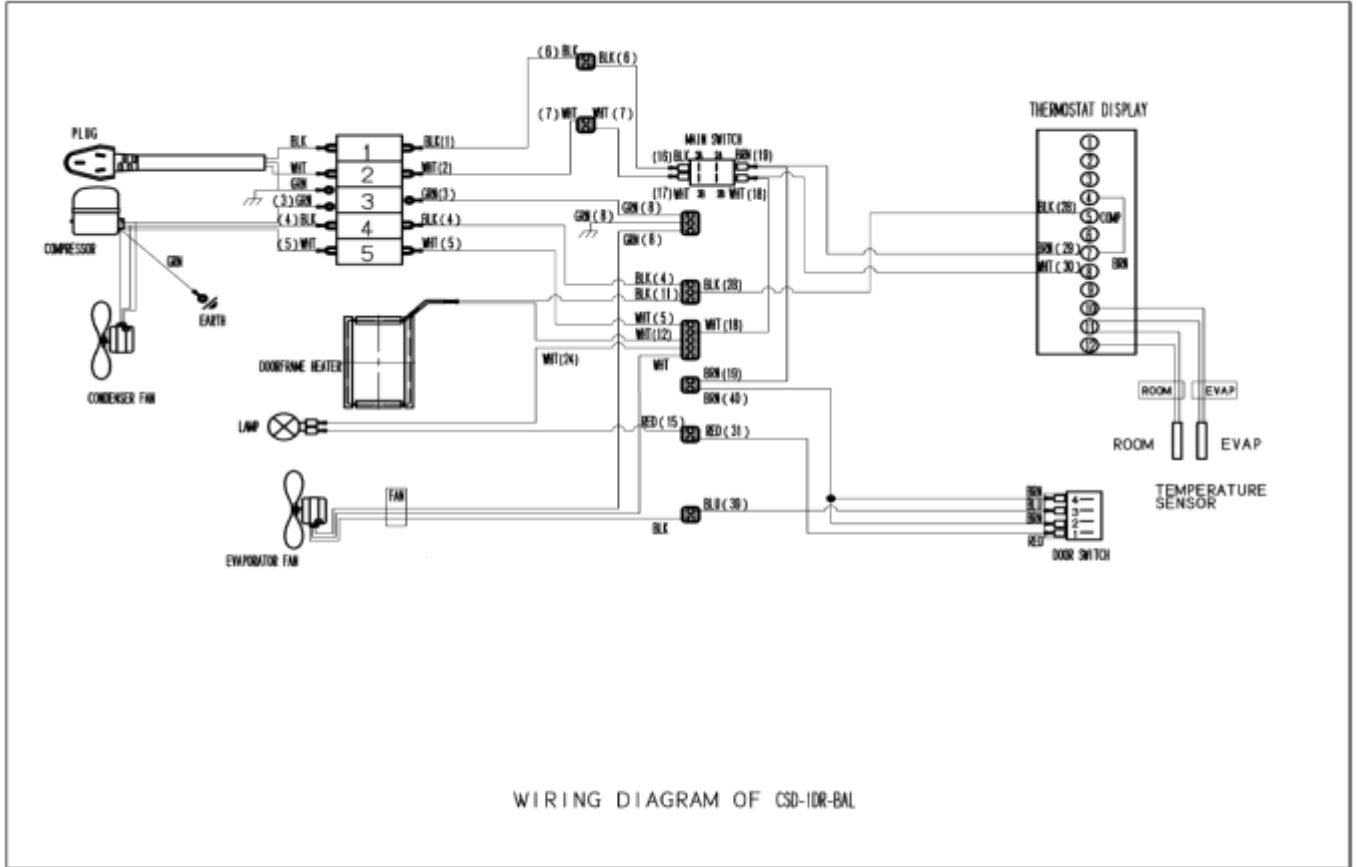

## Bottom Mount Two Door Refrigerator

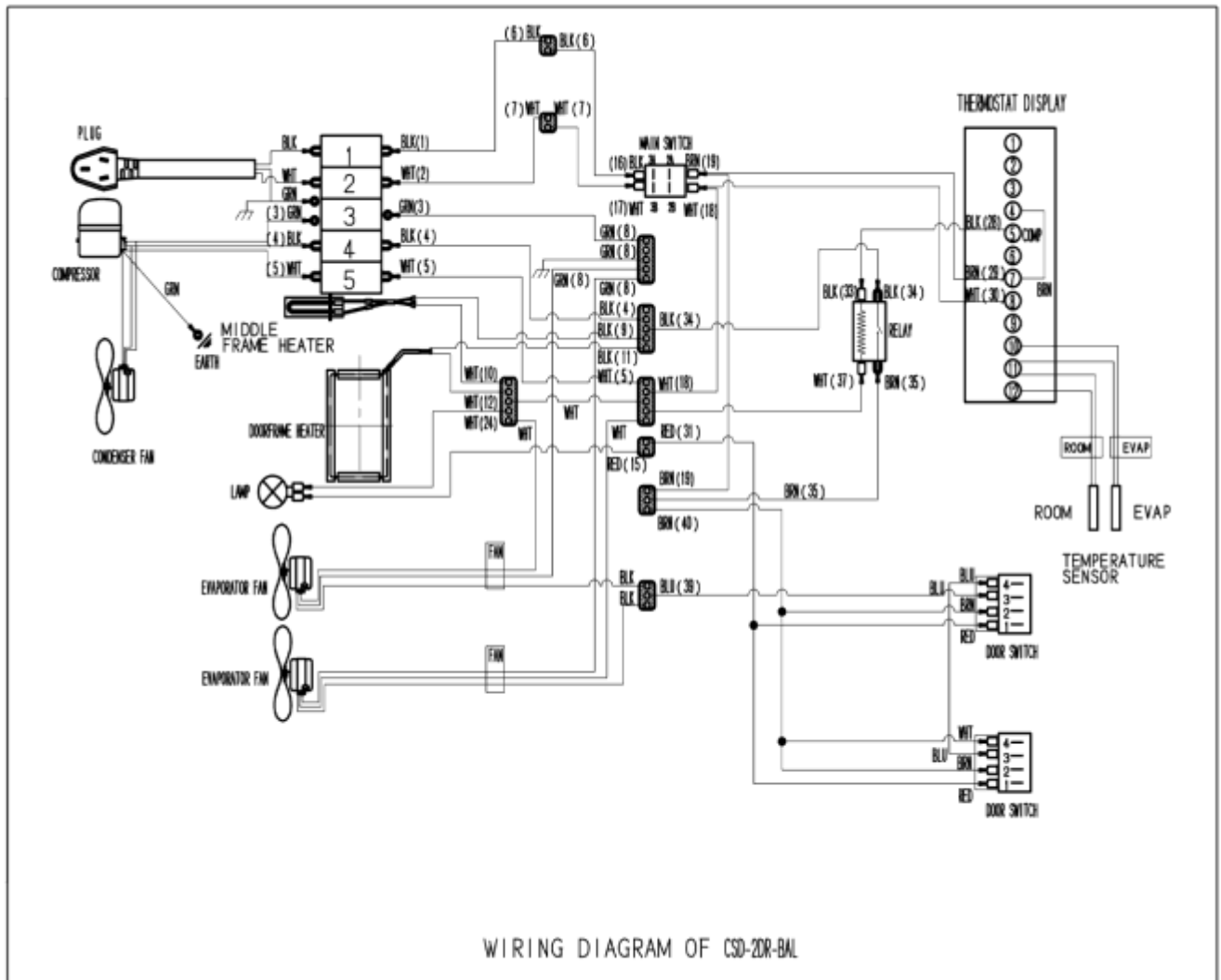



Bottom Mount Three Door Refrigerator

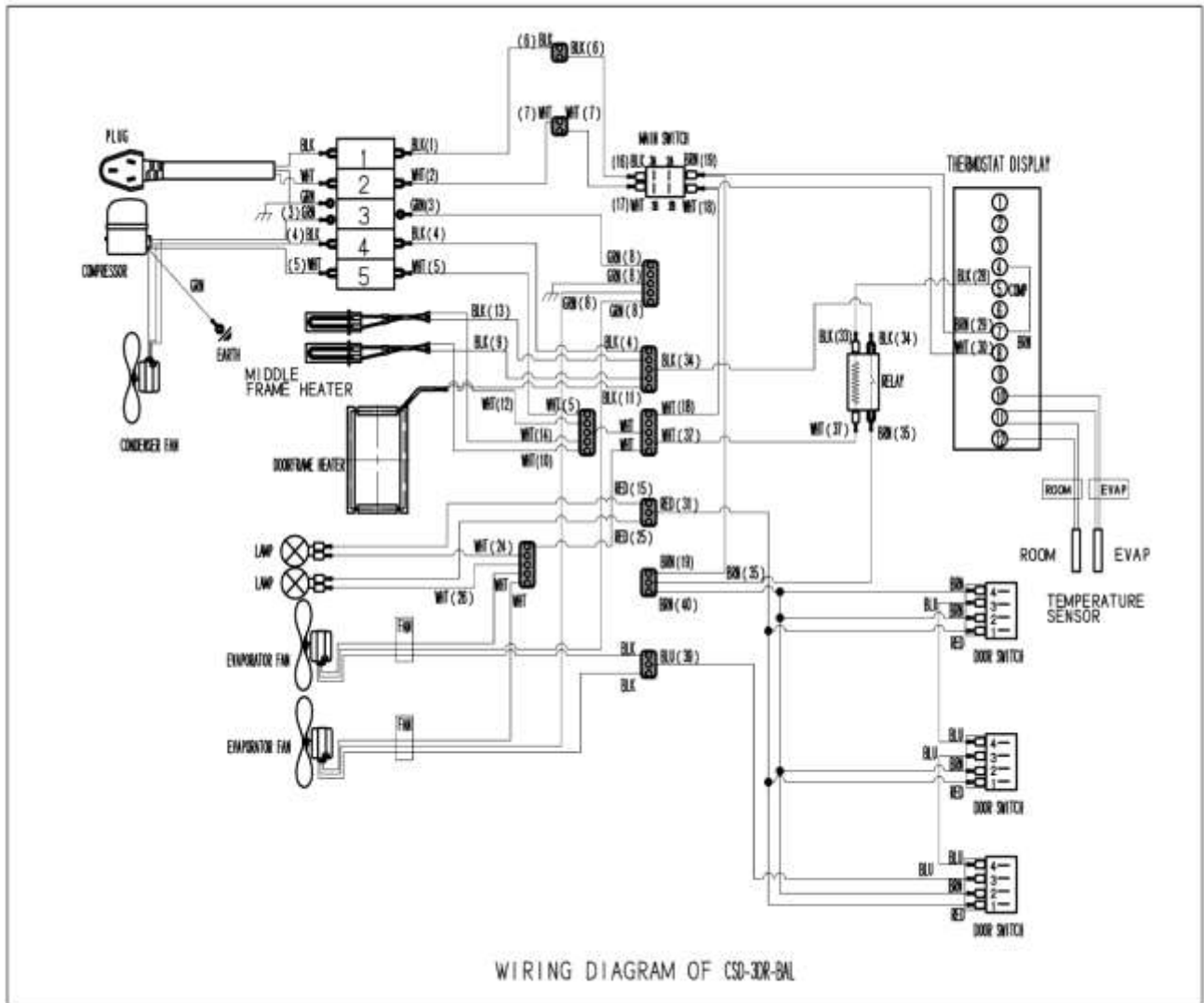

Bottom Mount One Door Freezer

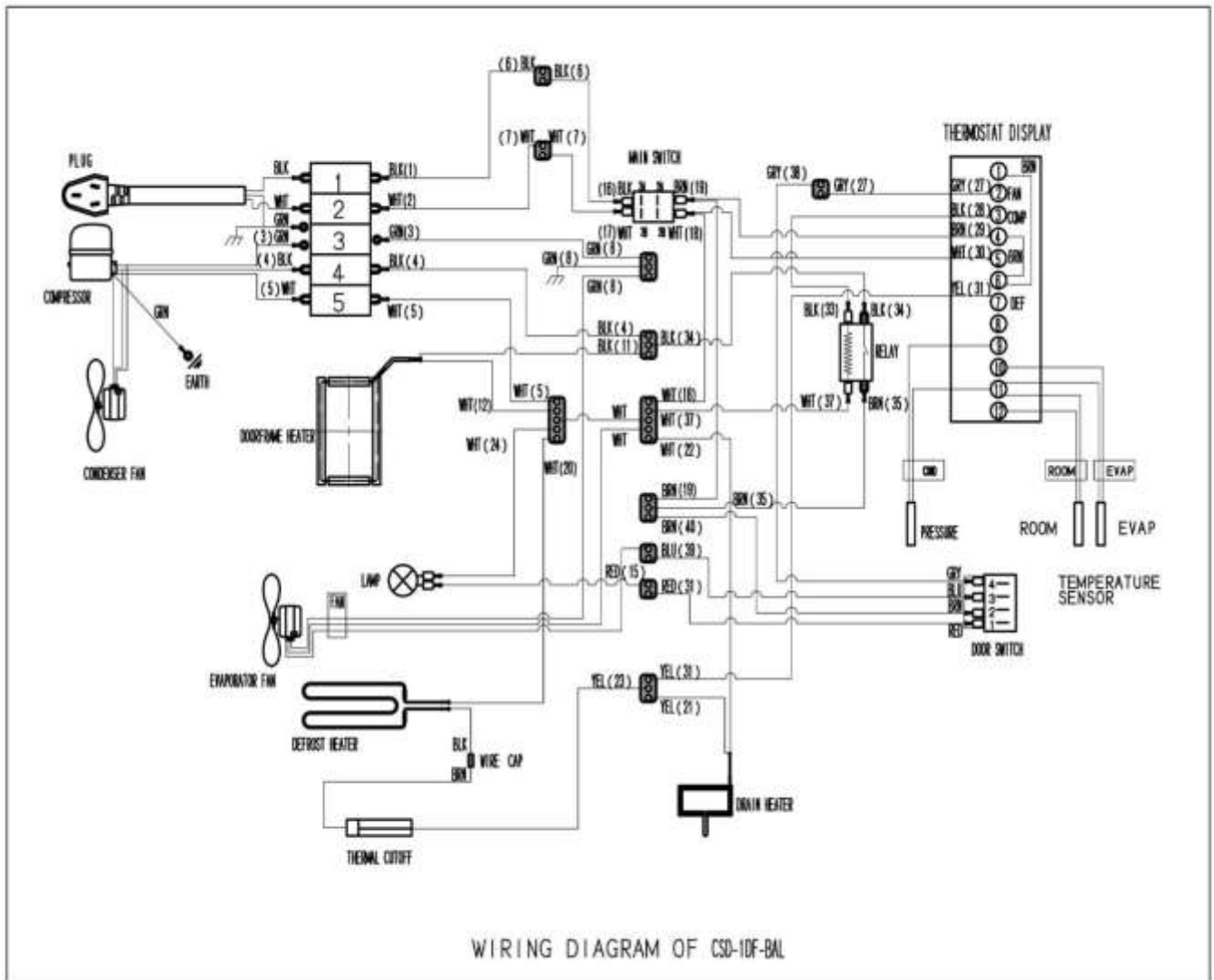

WIRING DIAGRAM OF CSD-1DF-BAL

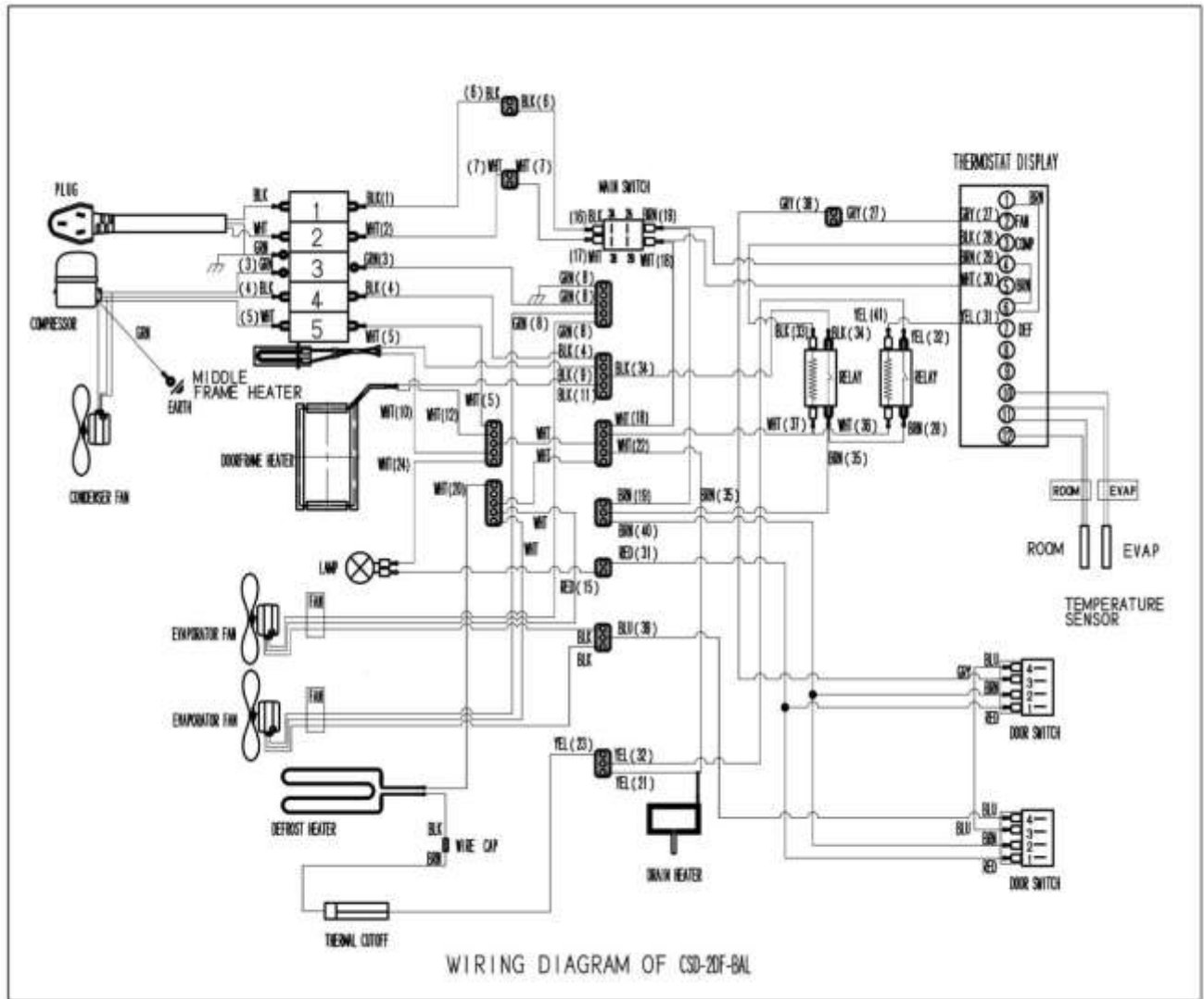

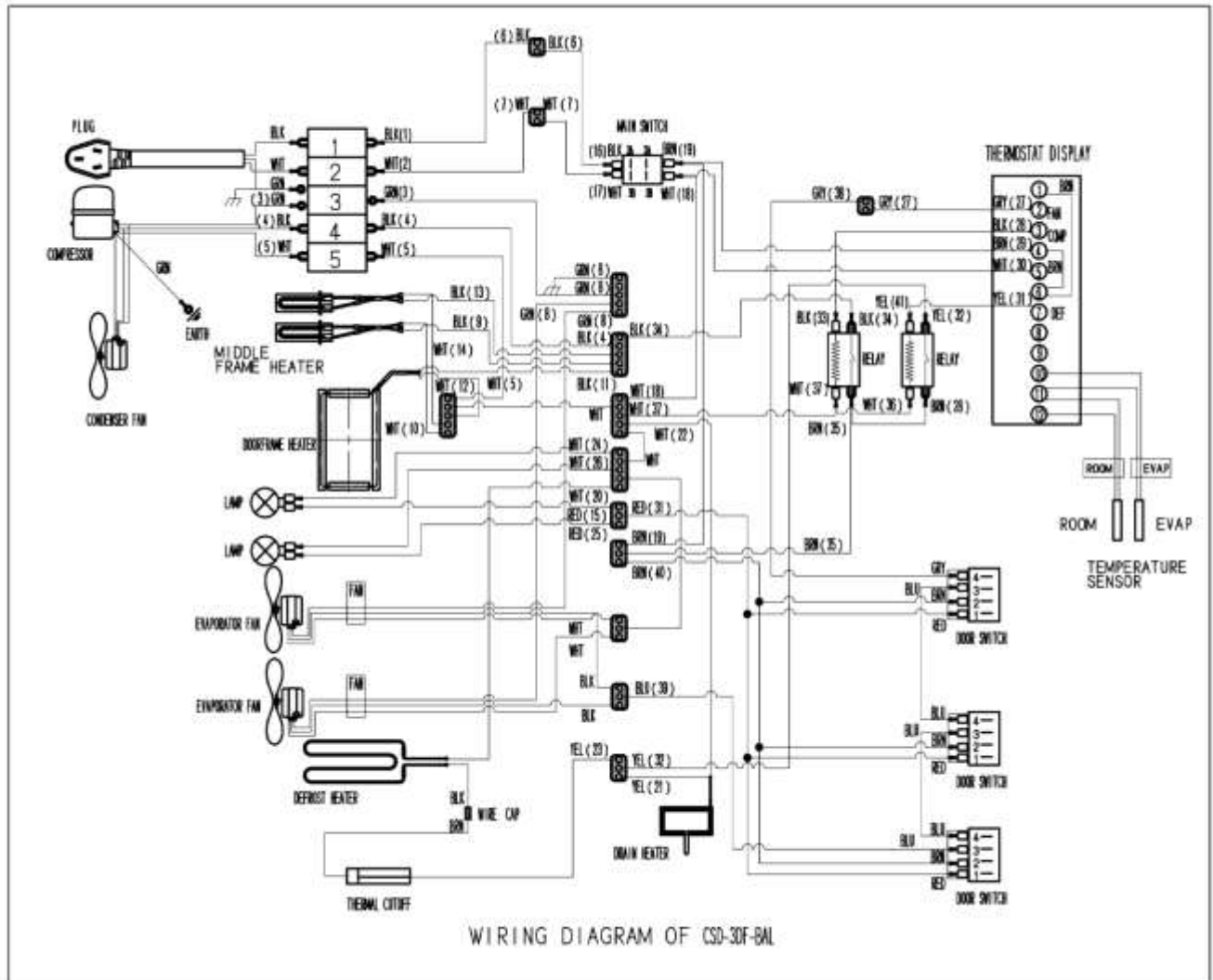

# Gentaur™ PLUS Top Mount One Door Refrigerator

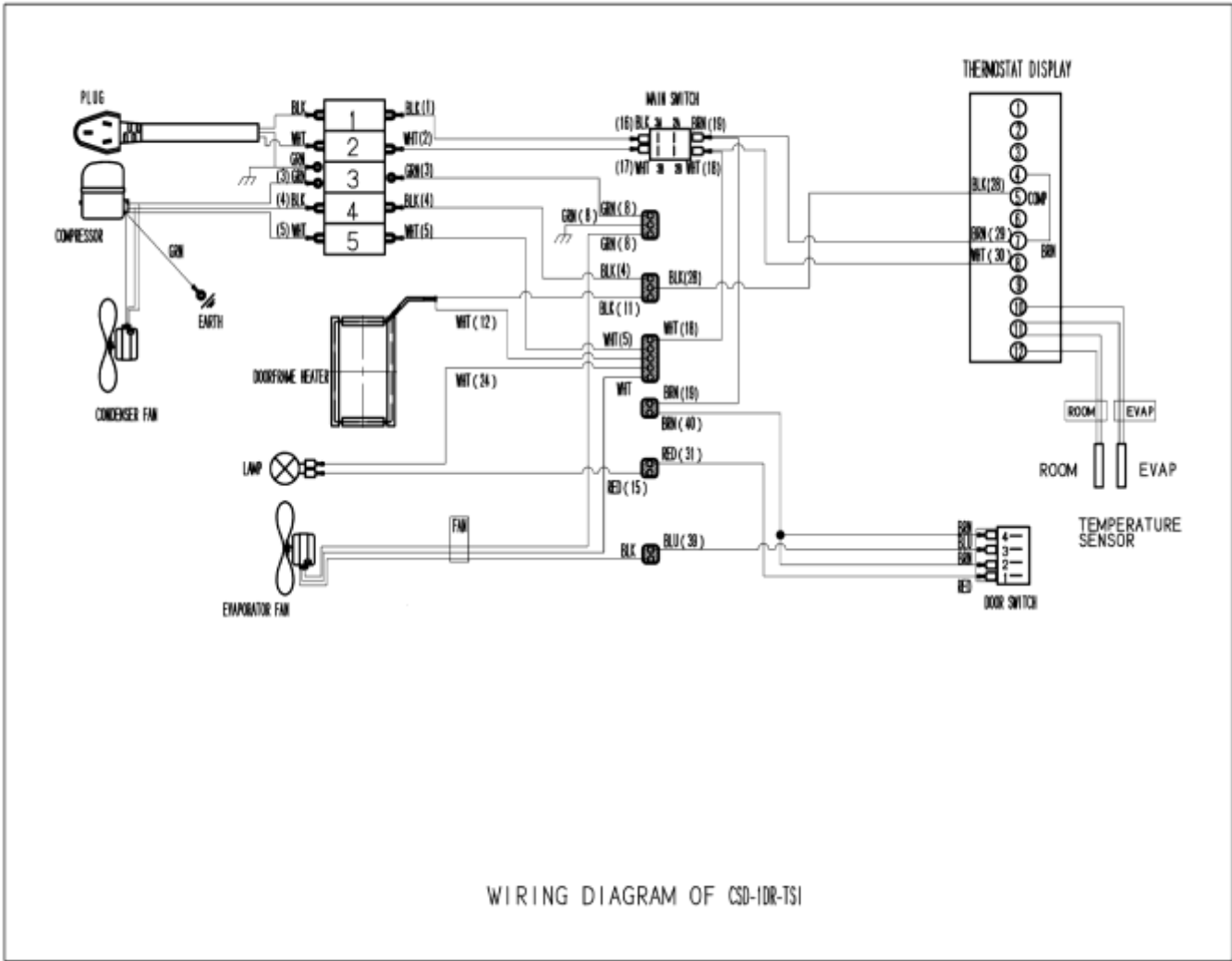

WIRING DIAGRAM OF CSD-1DR-TS1

# Centaur™ PLUS Top Mount Two Door Refrigerator

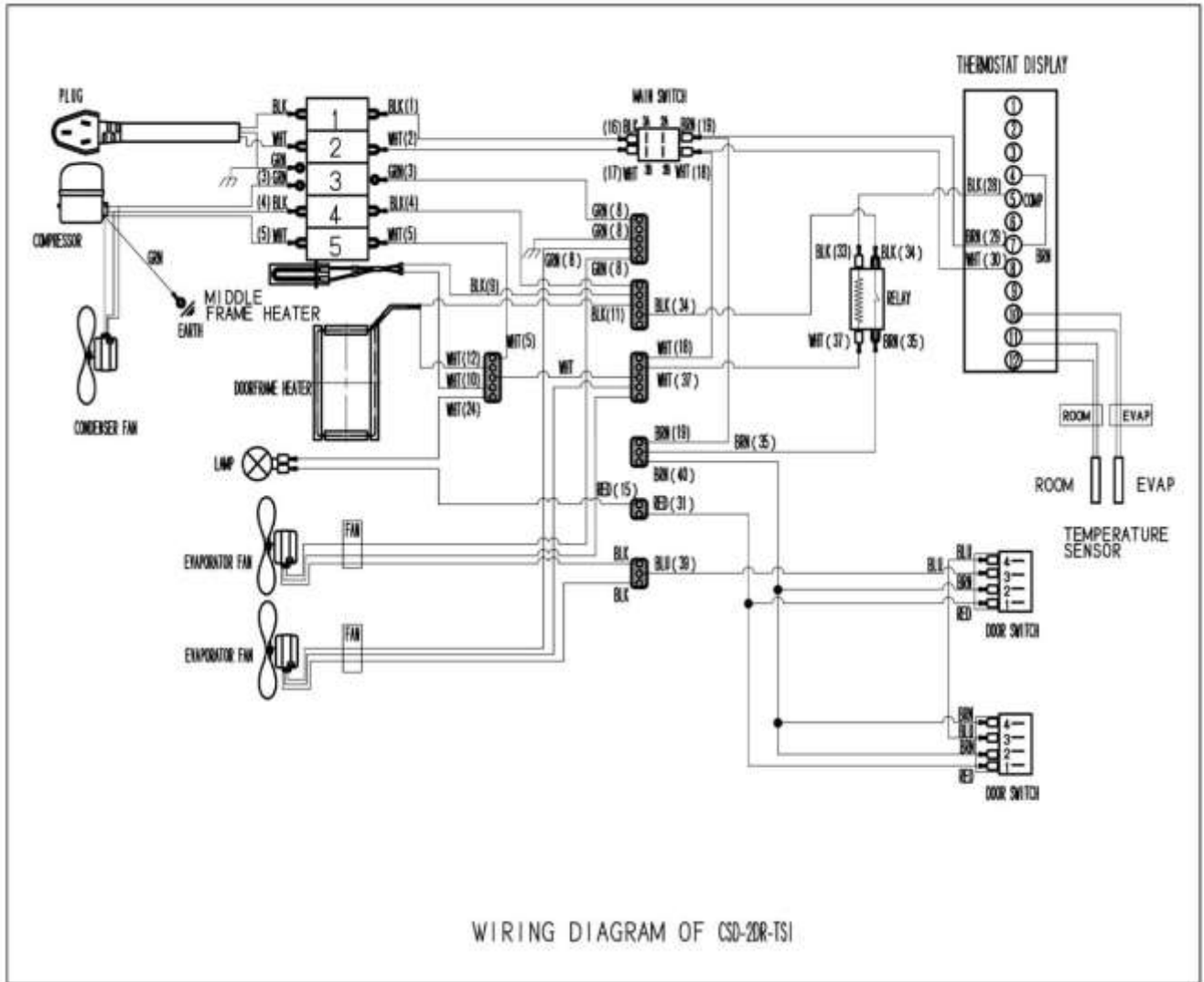

WIRING DIAGRAM OF CSD-2DR-TSI

# Centaur™ PLUS

## Top Mount Three Door Refrigerator

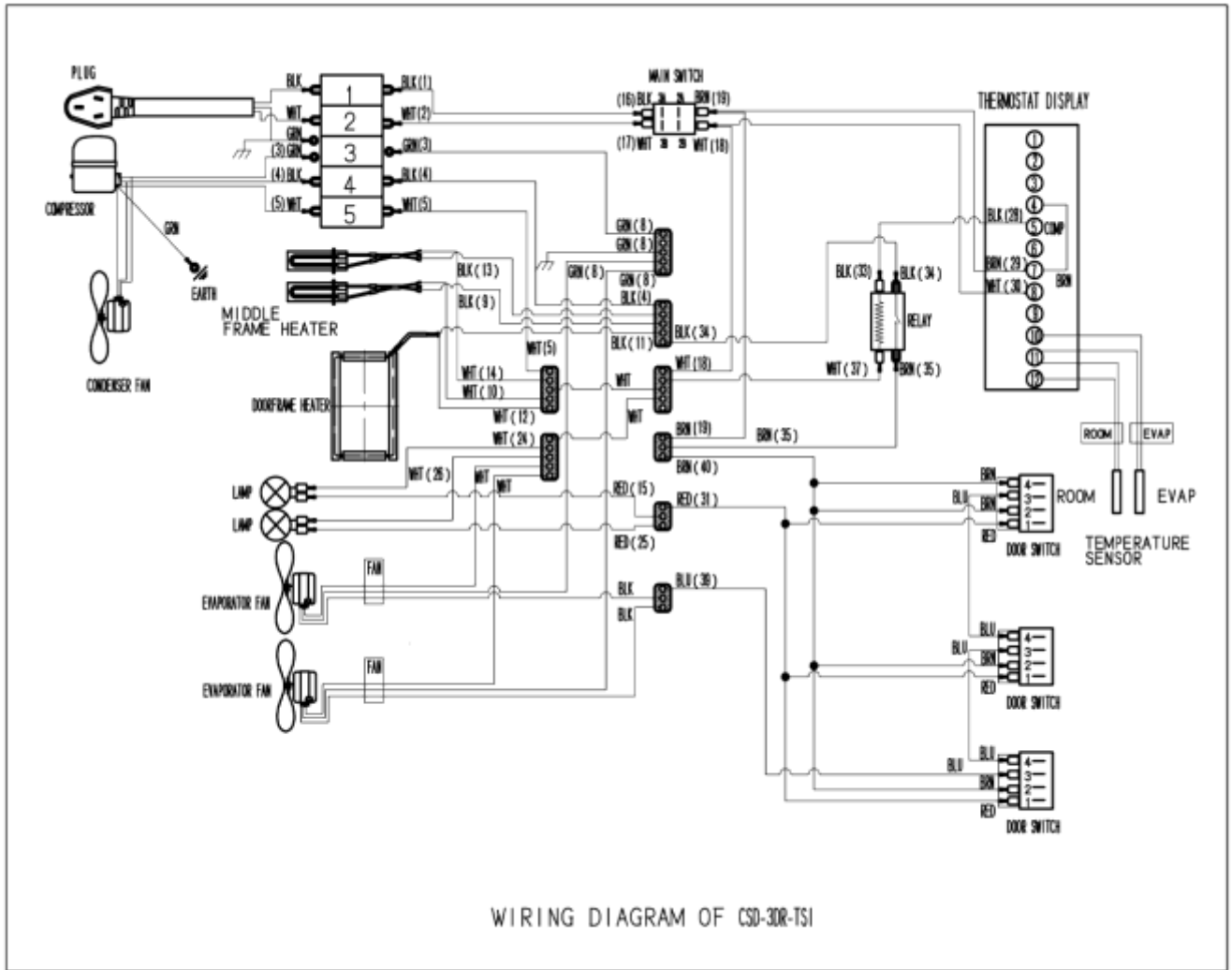

# Gentaur™ PLUS Top Mount One Door Freezer

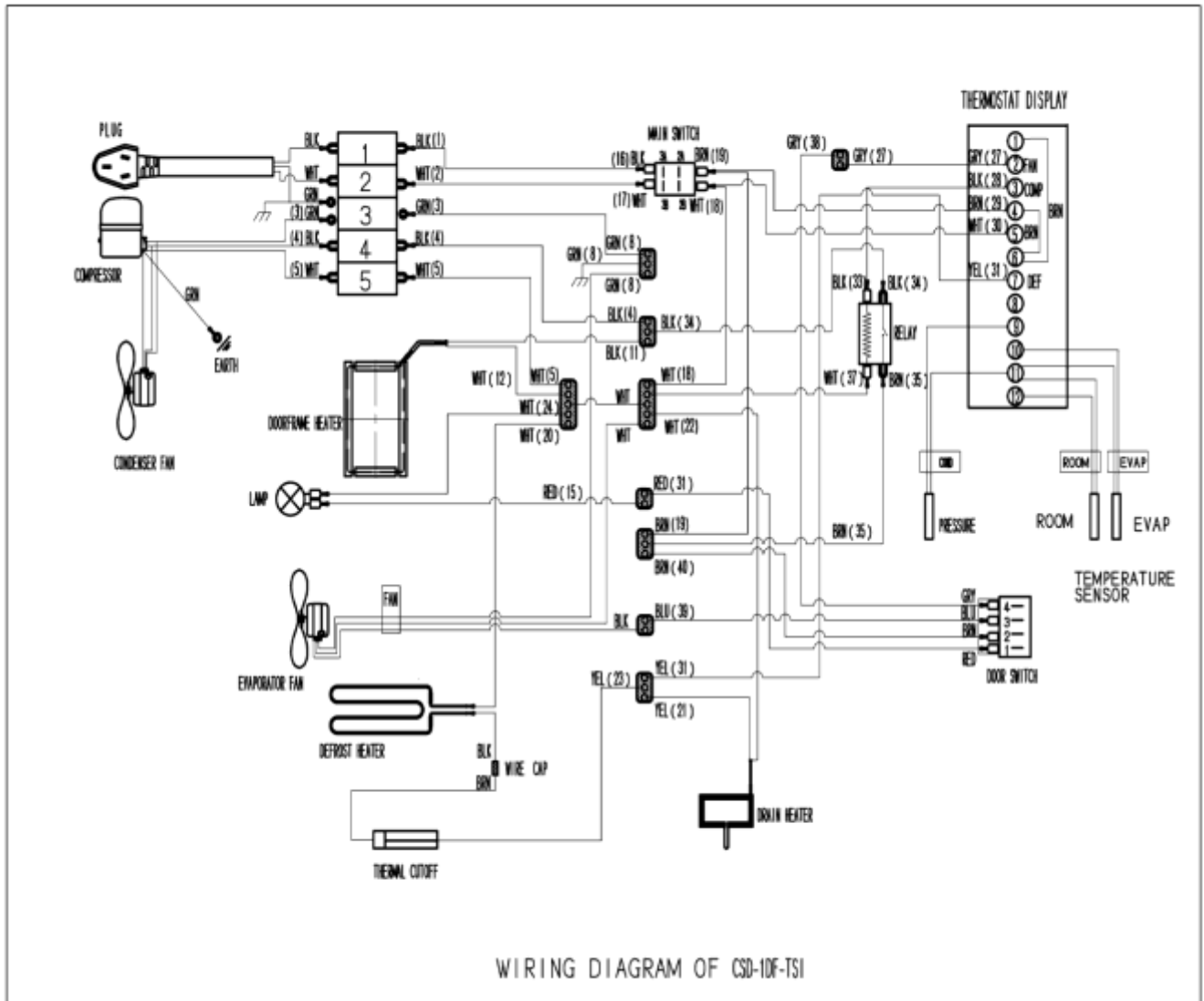

WIRING DIAGRAM OF CSD-1DF-TS1



# Centaur™ PLUS Top Mount Two Freezer

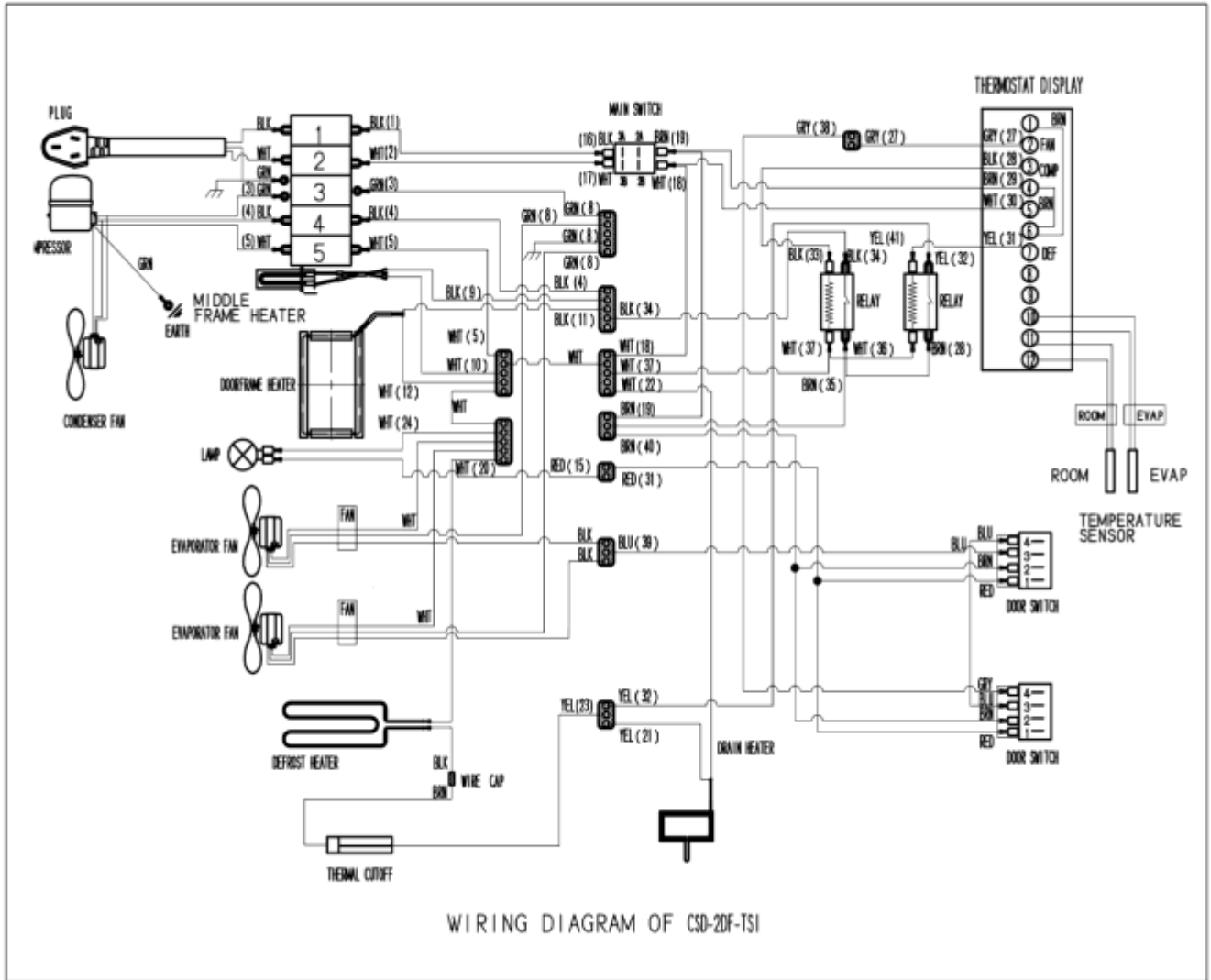

# Centaur™ PLUS

## Top Mount Three Door Freezer

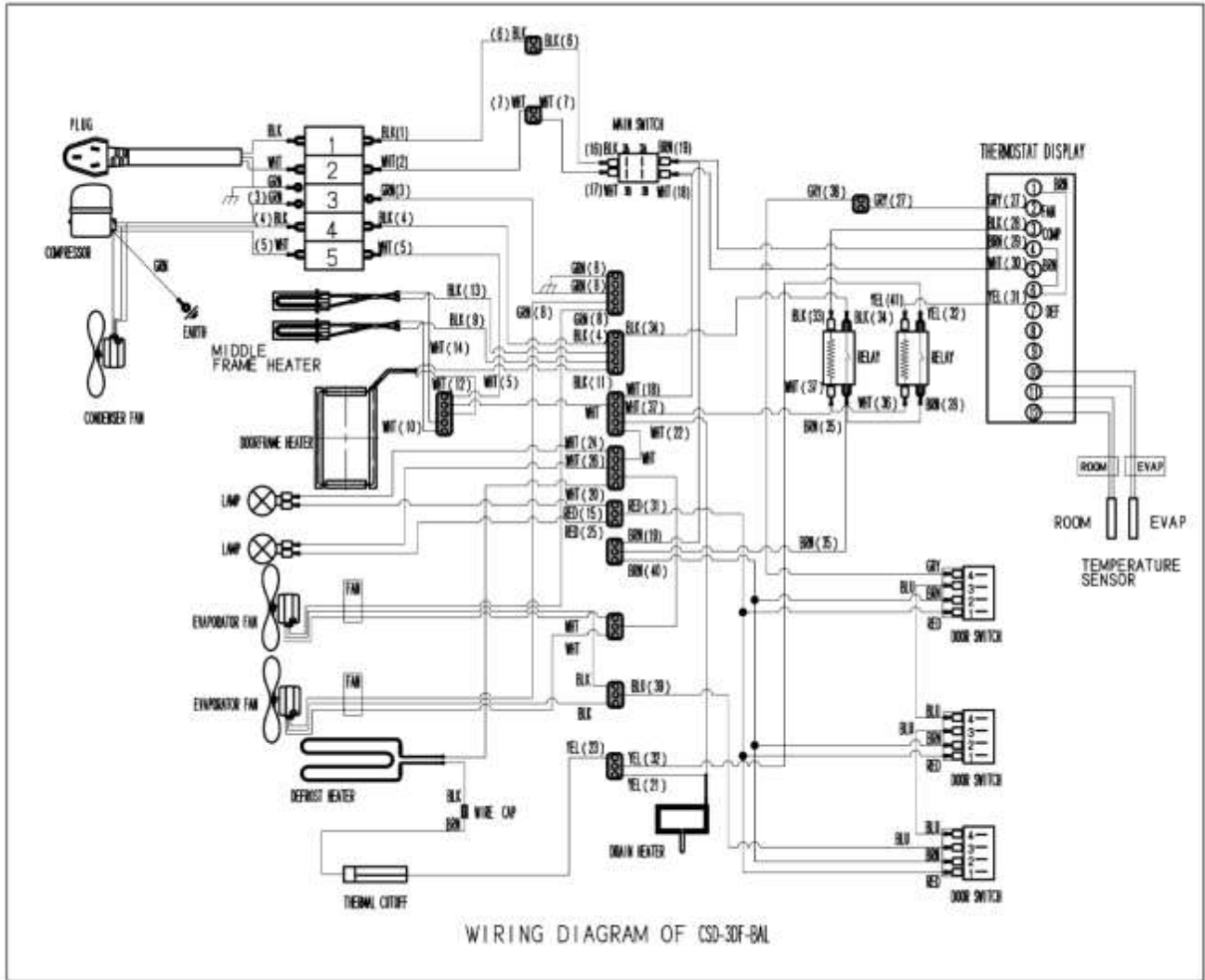

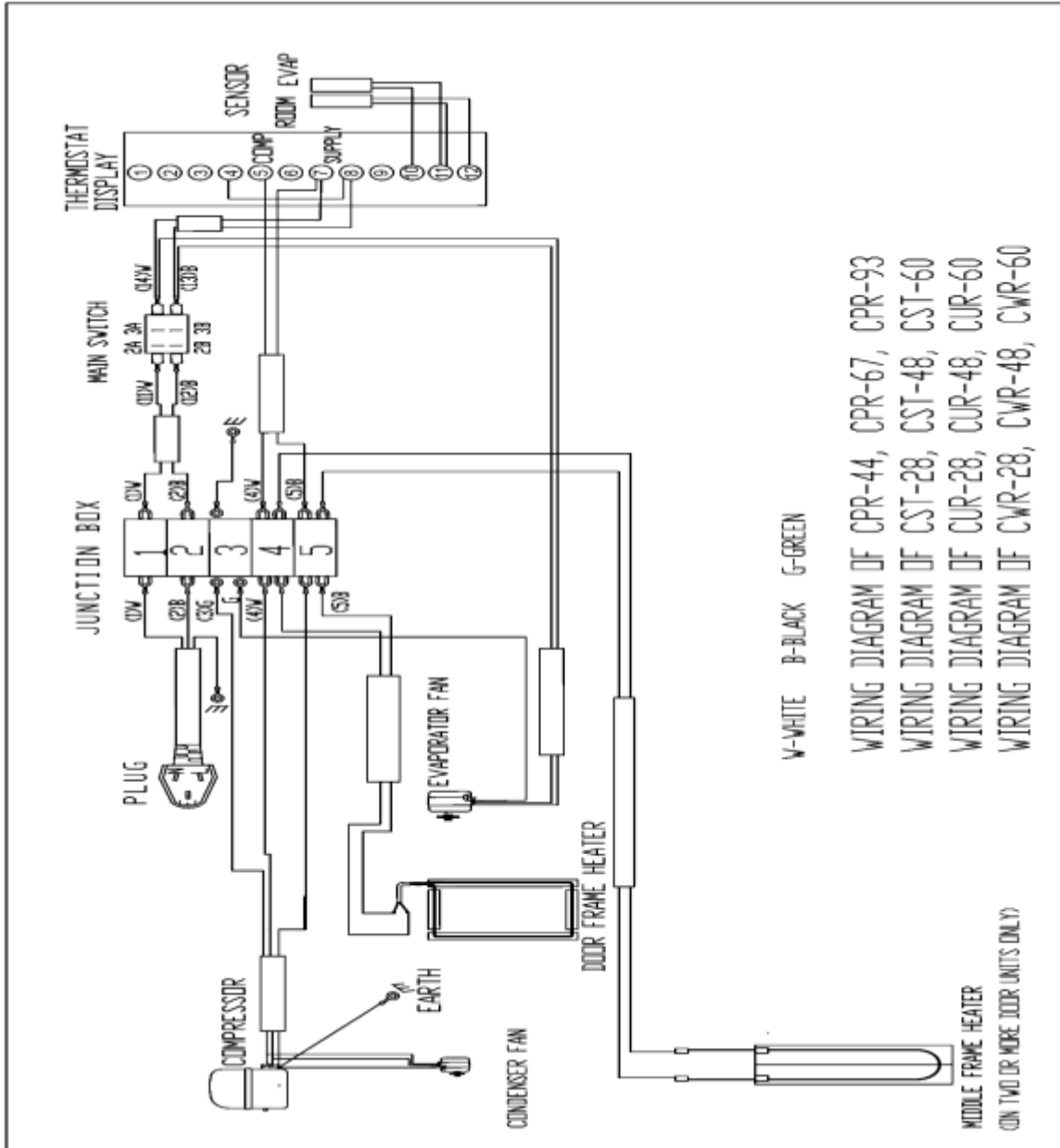

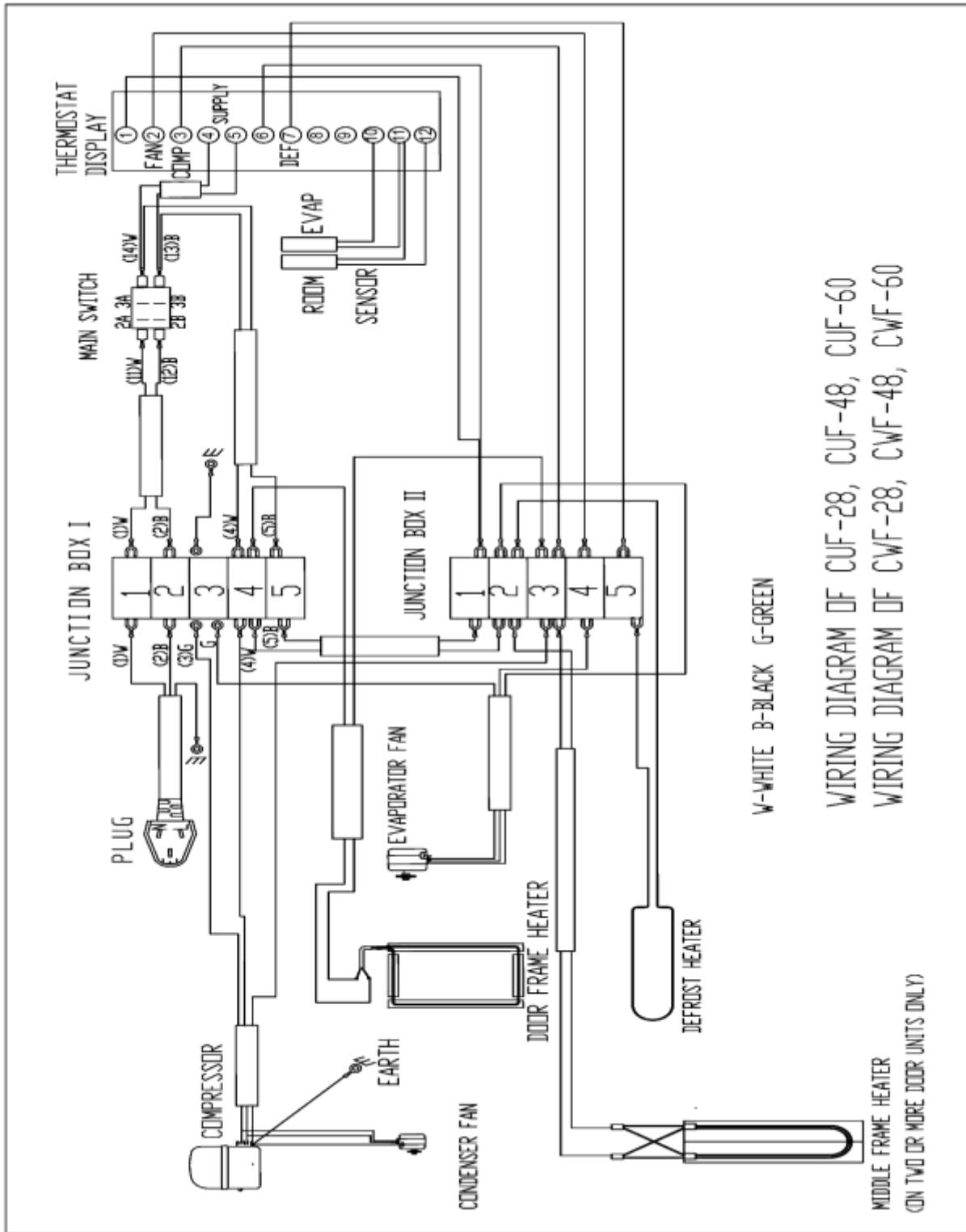

MODEL: CGD-1DR-12/CGD-1DR-16/CGD-1DR-23

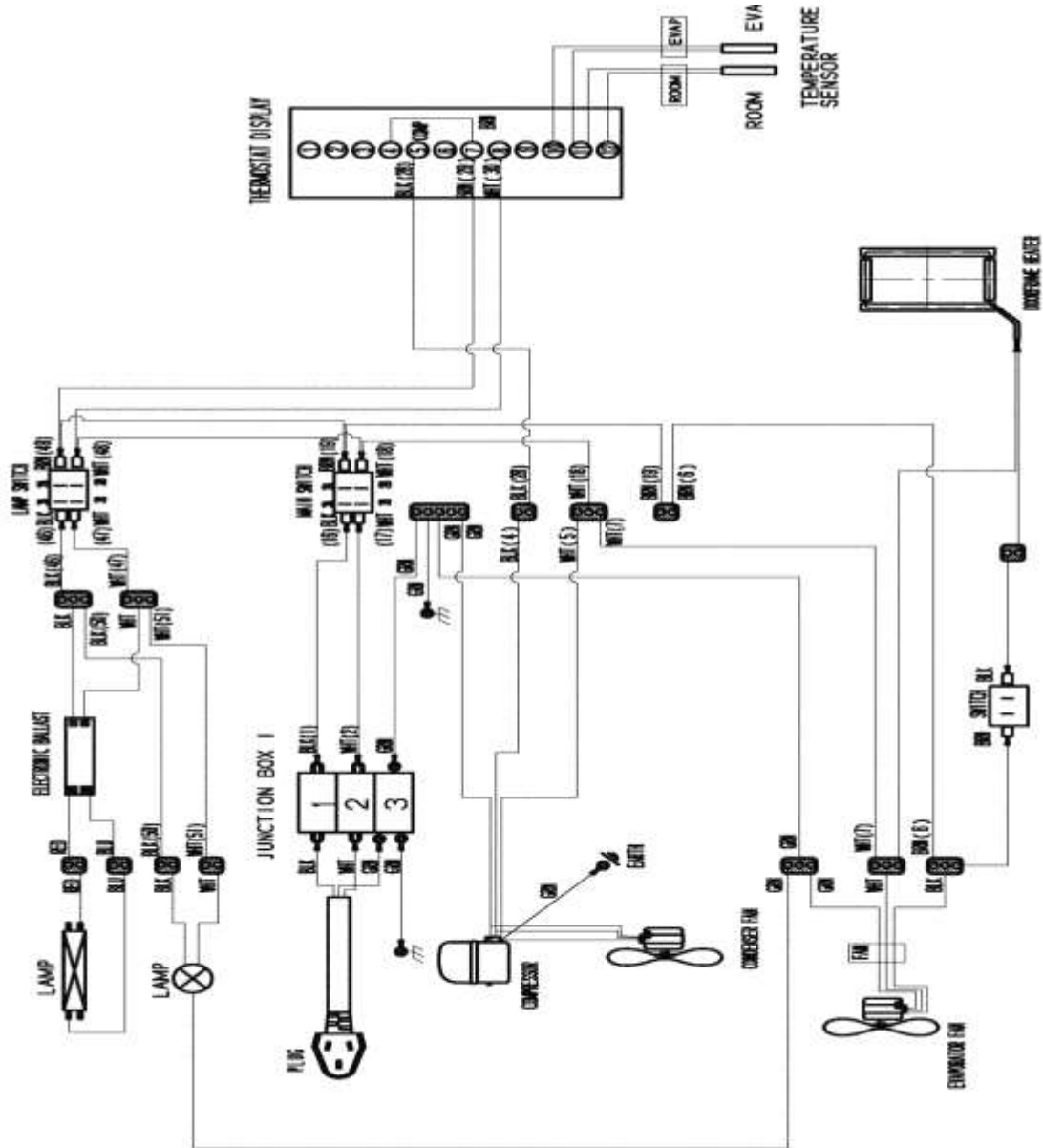



# Glass Door Merchandiser Two Door Refrigerator

MODEL: CGD-2DR-48/CGD-2DR-47

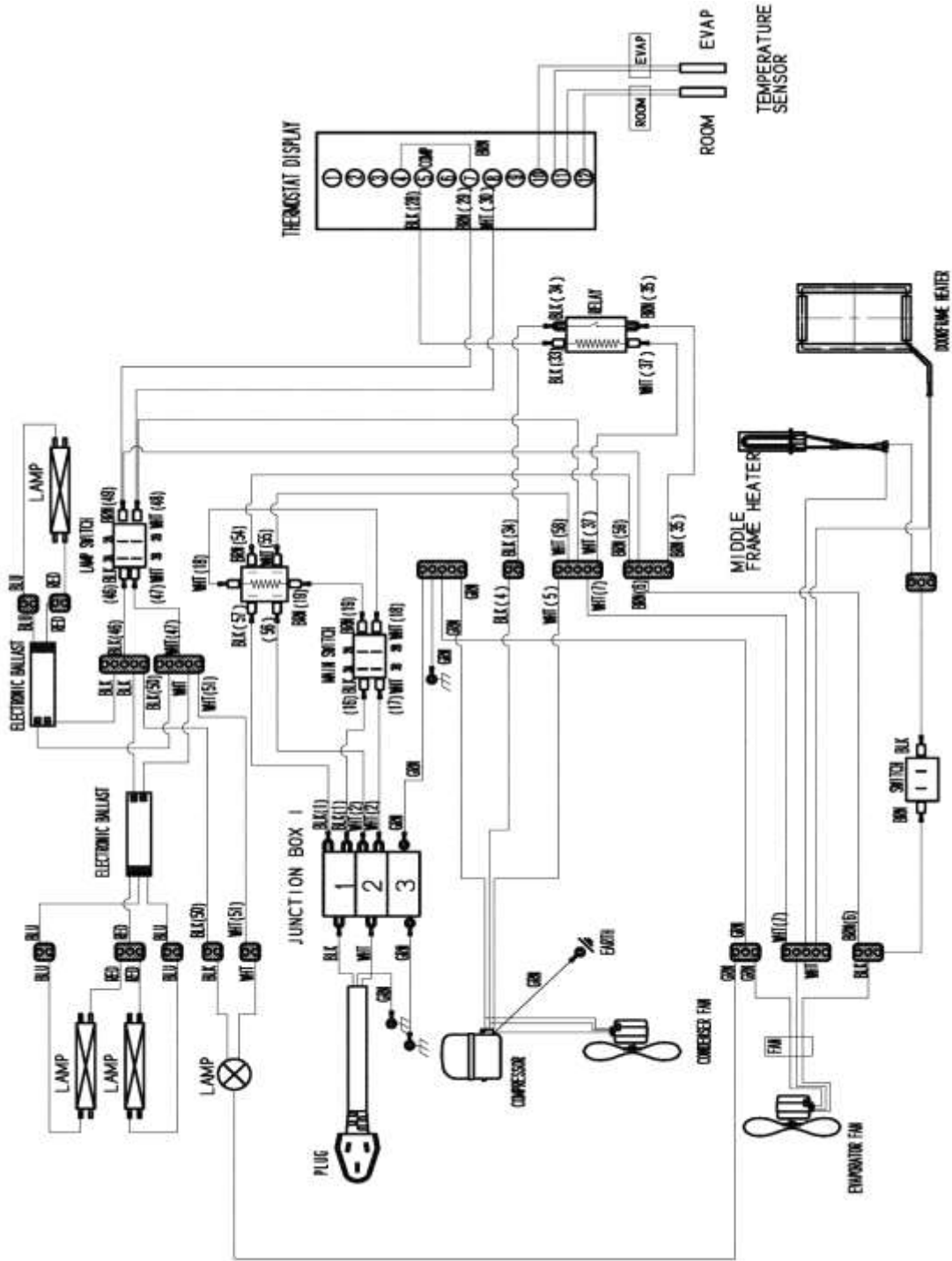

MODEL: CGD-3DR-70

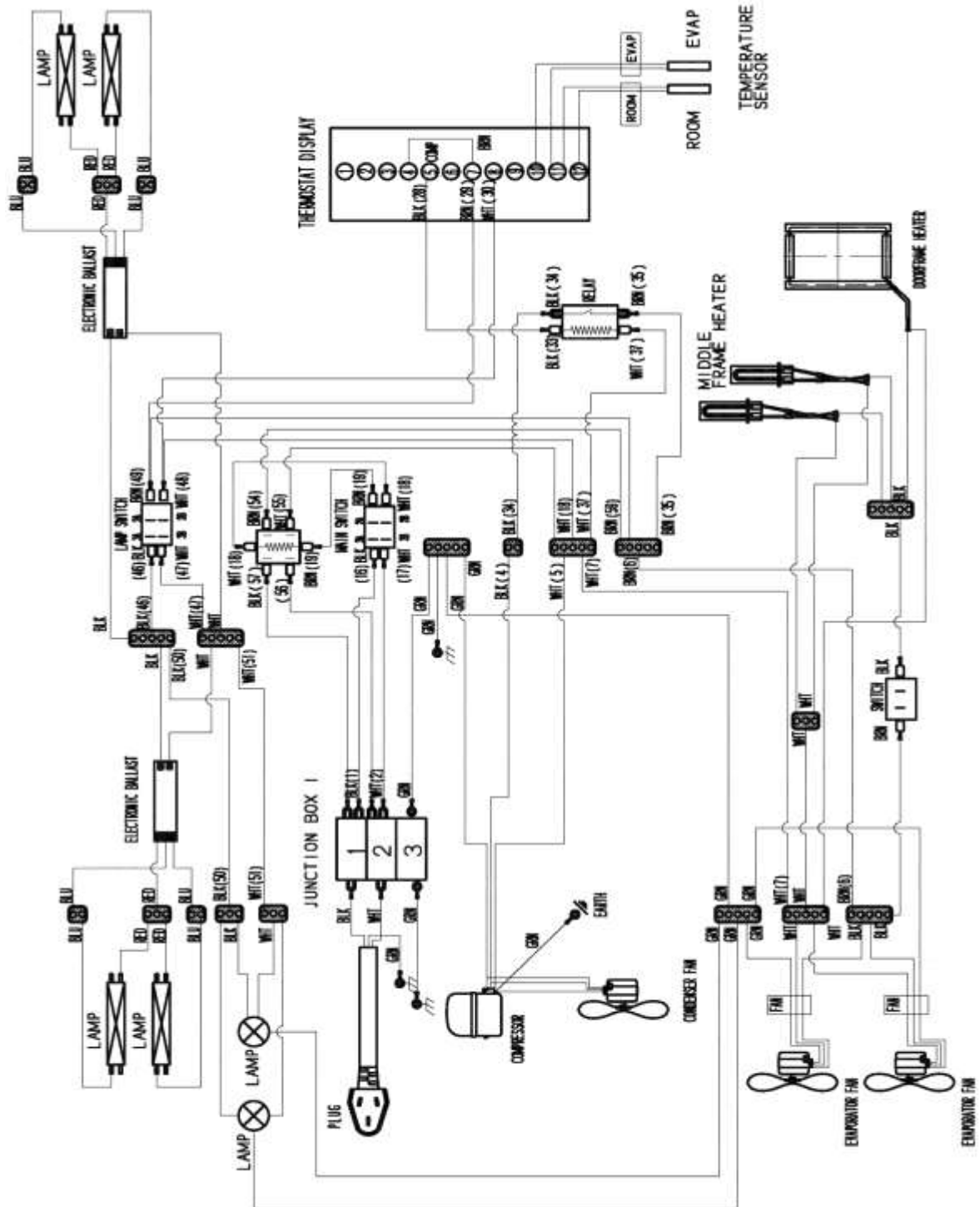

# Glass Door Merchandisers Freezers

MODEL: CGD-1DF-12/CGD-1DF-16/CGD-1DF-23

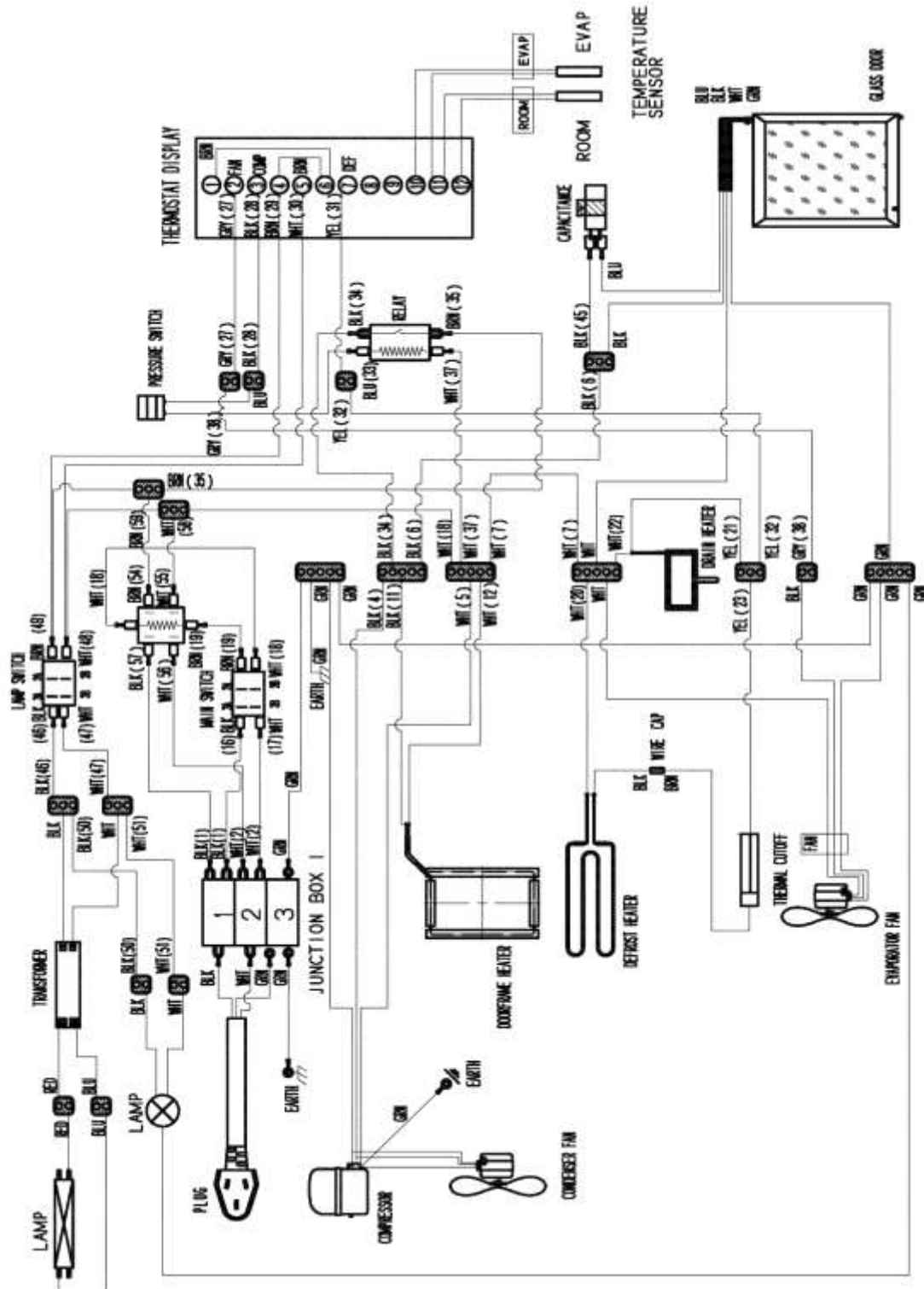



**Glass Door Merchandiser Two Door Freezer**

MODEL: CGD-2DF-48

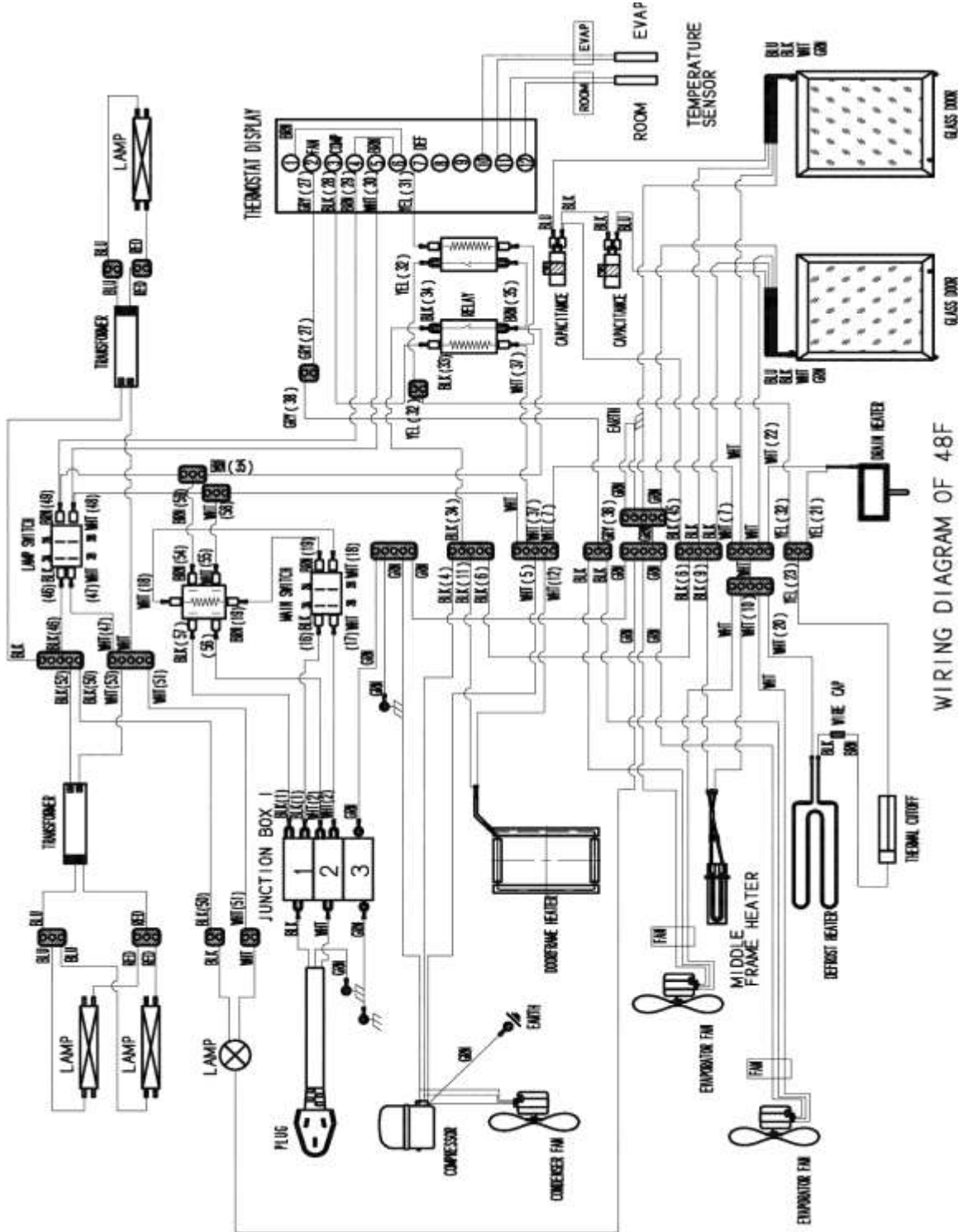

WIRING DIAGRAM OF 48F

**Glass Door Merchandiser Three Door Freezer**

MODEL: CGD-3DF-70

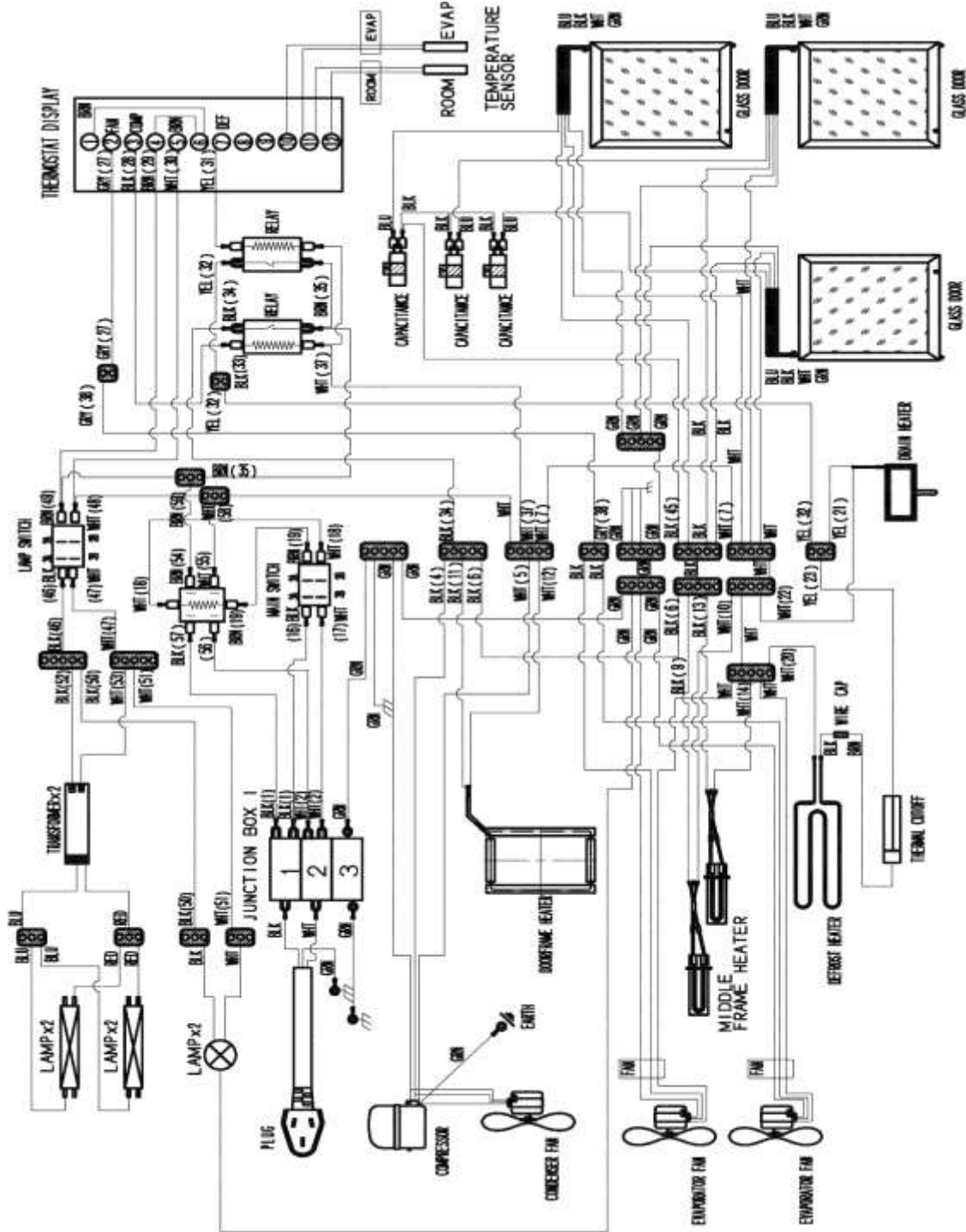

## ***Warranty Section***

### **Warranty Allowances for all Entrée Refrigeration Products**

All warranty claim invoices must include the following information for the invoice to be processed. If this information is not included on the invoice, it will be denied and returned with a letter of explanation.

- A. Serial Number
- B. Model Number
- C. End User (Customer) business name, location and phone number.
- D. Invoice must be signed by the customer or a person in their employment.
- E. The National Service Coop Service Request number.
- F. All invoices that are determined not to be a manufacturing defect will be denied.
- G. All invoices that are not readable will be returned with a denial letter.
- H. All invoices out of the guidelines of these allowances will be adjusted to the allowance, unless prior approval and accompanied by authorized number from the Entrée Technical Service Department.

**Entrée does not pay for Helper charges or Trainee charges. All work can be performed by one technician. Any Helper charges will have to be prior approved by Entrée Technical Service Department. Entrée Technical Support 1-704-464-3008 ext. 2**

#### **End Users (Customers) Responsibilities:**

- A. To verify through NSC the unit is under warranty. A Bill of Sale may be required.
- B. Pay for normal maintenance and adjustment. Entrée does not pay for adjustments, unless prior approved.
- C. To reimburse the service company for all non-warranty issues at the rates, travel time, etc. set by the service company. **Failure to do so could result in a void warranty.**
- D. Entrée does not pay overtime or holiday charges, additional travel charges not covered by warranty, equipment or tool charges not covered by warranty allowances.

**Entrée is not responsible for the loss of any product or economic loss as a result of failure of this product, caused by either, poor maintenance, acts of nature or defects.**

**Payment for Warranty Travel:**

A \$100.00 charge for the first trip and \$85.00 for the second trip with approval.

A \$120.00 charge for the first trip and \$100.00 for the second trip with approval for the following high traffic areas within the metro areas.

Atlanta, Boston, Chicago, Dallas-Ft. Worth, Ft. Lauderdale, Houston, Los Angeles, Miami, New York City, Philadelphia, San Diego, San Francisco or any area that would be considered a metro area.

**Warranty Parts Orders & Shipping Charges:**

All warranty parts sent out by Entrée parts department are shipped UPS ground at **no charge to** the Customer or the Service Company. All warranty parts that the customer request for Next Day Delivery will be paid for by the Customer. The Service Company will be required to secure payment of these charges from the Customer, and arrange for payment to Entrée for these shipping charges.

Entrée will send a replacement part at no charge for commonly used parts that are held in inventory by the Service Company and are used to repair a unit.

For non-inventory parts, we will ship at no charge. If we do not have the part in stock and it can be acquired locally, Entrée will pay for the purchase cost of the part and \$45.00 travel fee to acquire the part. A copy of the invoice for the part must be submitted with the warranty claim.

**Warranty Parts Return:**

Entrée does not require at this time warranty defective parts to be returned. Entrée does not pay any handling fees for parts return. If a warranty part is required to be returned, Entrée Technical Department will notify the Service Company and pay shipping charges of all returned parts.

**Warranty Hourly Rates:**

Please refer to the National Service Coop Rate Structure.

**Labor Allowances for Reach-in Freezers, Refrigerators, Sandwich/Salad, Pizza Tables, Work Tops, Under Counter Units.**

**Any labor hours out of these guidelines without prior approval by Entrée will be adjusted to the guidelines. These time guidelines are based on the national average of other manufactures of the same type of equipment.**

## Refrigeration System:

- A. Diagnose and replace a defective compressor. This includes the starting components, drier, recovery, welding, vacuum and recharge & test system..... 4.5 Hours
- B. Diagnose and replace a defective evaporator coil. This includes drier, welding, recovery, vacuum, recharge & test..... 5 Hours
- C. Diagnose and replace a defective condenser coil. This includes drier, welding, recovery, vacuum, recharge & test.....4 Hours
- D. Diagnose and replace a defective or restricted capillary tube. This includes drier, welding, recovery, vacuum, recharge & test.....5 Hours
- E. Diagnose and locate a refrigerant leak. Leak location must be entered on the service invoice. Entrée does not install Schrader or tap valves on its systems. Any leak located on these components WILL NOT be considered a defect, but a call back on the service company.....4 Hours
- F. All other defective refrigeration components. This includes drier, welding, recovery, vacuum, recharge & test.....4 Hours

## Cabinet:

- A. Replace a defective door gasket.....1 Hour
- B. Replace a defective door..... 1.5 Hours
- C. Replace a defective caster.....1 Hour
- D. Replace a bottom shroud.....1 Hour
- E. Replace a top shroud with controller mounted on it.....1.5 Hours
- F. Replace a defective door hinge .....2 Hours
- G. Replace a defective door lock.....1 Hour

## Electrical Components:

- A. Diagnose and replace compressor starting components.....3 Hours
- B. Diagnose and replace a contactor.....2 Hours
- C. Diagnose and locate an electrical short.....3 Hours
- D. Diagnose and replace a terminal board.....2 Hours
- E. Diagnose and replace a controller.....2 Hours
- F. Diagnose and replace a controller with sensors.....3 Hours
- G. Diagnose and replace a defrost heater .....3.5 Hours
- H. Diagnose and replace a drain line heater .....3.5 Hours
- I. Diagnose and replace a thermal cutoff ..... 3 Hours
- J. Diagnose and replace a power switch .....2 Hours
- K. Diagnose and replace a door (light & fan) switch .....2 Hours
- L. Diagnose and replace a power cord.....2 Hours

**Motors:**

- A. Diagnose and replace a condenser fan motor.....2 Hours
- B. Diagnose and replace a evaporator fan motor .....1.5 Hours
- C. Diagnose and replace a condenser or evaporator fan blade.....1.5 Hours

**Other Allowance:**

Entrée will allow a \$45.00 miscellaneous charge. This to include all of the following: recovery unit, vacuum pump use, welding use, nitrogen, electrical test equipment, electrical fittings, rags and cleaning supplies. All other will be adjusted out.

Entrée will pay a reasonable price for any tap valves, driers, etc. used in the repair of the refrigeration system.

**Refrigerant Allowance:**

Entrée will pay the following price per ounce of refrigerant. We will also allow a few extra ounces for leak testing, etc.

Refrigerant R-134a = \$0.59 per ounce

Refrigerant R-404a = \$0.83 per ounce

Any other refrigerant blends used other than those called for on the name plate of the unit will VOID the warranty on that unit.

**Multiple Repairs on the Same Unit:**

A system that has more than one component failure. The service company can use the highest time for the first component plus 1 hour for the additional component. Entrée will pay only one trip charge for the first component.

Any items not covered by this warranty allowances you can call the:

**Technical Support Department @ 570-752-4602**

## Maintenance and Care



The power switch must be turned to OFF and the unit disconnected from the power source whenever performing service, maintenance functions or cleaning the refrigerated area.

### Refrigerators and Freezers

The interior and exterior can be cleaned using soap and warm water. If this isn't sufficient, try ammonia and water or a nonabrasive liquid cleaner. When cleaning the exterior, always rub with the "grain" of the stainless steel to avoid marring the finish.

Do not use an abrasive cleaner because it will scratch the stainless steel and plastic and can damage the breaker strips and gaskets.

### Cleaning the Condenser Coil

The condenser coil requires regular cleaning, recommended is every 90 days. In some instances though you may find that there is a large amount of debris and dust or grease accumulated prior to the 90 days time frame. In these cases the condenser coil should be cleaned every 30 days.

If the build up on the coil consists of only light dust and debris the condenser coil can be cleaned with a simple brush, heavier dust build up may require a vacuum or even compressed air to blow through the condenser coil.

If heavy grease is present there are de-greasing agents available for refrigeration use and specifically for the condenser coils. The condenser coil may require a spray with the de-greasing agent and then blown through with compressed air.

Failure to maintain a clean condenser coil can initially cause high temperatures and excessive run times, continuous operation with dirty or clogged condenser coils can result in compressor failures. Neglecting the condenser coil cleaning procedures will void any warranties associated with the compressor or cost to replace the compressor.



**Never use a high pressure water wash for this cleaning procedure as water can damage the electrical components located near or at the condenser coil.**

In order to maintain proper refrigeration performance, the condenser fins must be cleaned of dust, dirt and grease regularly. It is recommended that this be done at least every three months. If conditions are such that the condenser is totally blocked in three months, the frequency of cleaning should be increased. Clean the condenser with a vacuum cleaner or stiff brush. If extremely dirty, a commercially available condenser cleaner may be required.

### Stainless Steel Care and Cleaning

To prevent discoloration of rust on stainless steel several important steps need to be taken. First, we need to understand the properties of stainless steel. Stainless steel contains 70-80% iron which will rust. It also contains 12-30% chromium which forms an invisible passive film over the steels surface which acts as a shield against corrosion. As long as the protective layer is intact, the metal is still stainless. If the film is broken or contaminated, outside elements can begin to breakdown the steel and begin to form rust or discoloration.

Proper cleaning of stainless steel requires soft cloths or plastic scouring pads.



**NEVER USE STEEL PADS, WIRE BRUSHES OR SCRAPERS!**

Cleaning solutions need to be alkaline based or non-chloride cleaners. Any cleaner containing chlorides will damage the protective film of the stainless steel. Chlorides are also commonly found in hard water, salts, and household and industrial cleaners. If cleaners containing chlorides are used be sure to rinse repeatedly and dry thoroughly upon completion.

Routine cleaning of stainless steel can be done with soap and water. Extreme stains or grease should be cleaned with a non-abrasive cleaner and plastic scrub pad. It is always good to rub with the grain of the steel. There are also stainless steel cleaners available which can restore and preserve the finish of the steels protective layer.

Early signs of stainless steel breakdown can consist of small pits and cracks. If this has begun, clean thoroughly and start to apply stainless steel cleaners in attempt to restore the passivity of the steel.



**Never use an acid based cleaning solution! Many food products have an acidic content which can deteriorate the finish. Be sure to clean the stainless steel surfaces of ALL food products. Common items include, tomatoes, peppers and other vegetables.**



If your freezer seems to vibrate excessively when the compressor is running, loosen (but do not remove) the bolts on the compressor.

## MAINTENANCE

### Gasket Maintenance

Gaskets require regular cleaning to prevent mold and mildew build up and also to keep the elasticity of the gasket. Gasket cleaning can be done with the use of warm soapy water. Avoid full strength cleaning products on gaskets as this can cause them to become brittle and prevent proper seals. Also, never use sharp tools or knives to scrape or clean the gasket which could possibly tear the gasket and rip the bellows.

Gaskets can easily be replaced and do not require the use of tools or authorized service persons. The gaskets are "Dart" style and can be pulled out of the groove in the door and new gaskets can be "pressed" back into place.

### Doors/Hinges

Over time and with heavy use doors the hinges may become loose. If it is noticed that the door is beginning to sag, it may become necessary to tighten the screws that mount the hinge brackets to the frame of the unit. If the doors are loose or sagging this can cause the hinge to pull out of the frame which may damage both the doors and the door hinges. In some cases this can require qualified service agents or maintenance personnel.

### Drain Maintenance

Each unit has a drain located inside the unit which removes the condensation from the evaporator coil and evaporates it at an external condensate evaporator pan. Each drain can become loose or disconnected from moving or bumping the drain. If you notice excessive water accumulation on the inside of the unit be sure the drain tube is connected from the evaporator housing to the condensate evaporator drain pan. If water is collected underneath the unit you may want to check the condensate evaporator drain tube to be sure it is still located inside the drain pan. The leveling of the unit is important as the units are designed to drain properly when on a level surface, if your floor is not level this can also cause drain problems. Be sure all drain lines are free of obstructions typically food product is found blocking drain lines causing water to back up and overflow the drain pans.

### Open the top shroud

Loosen the screws on the bottom of top shroud, then swing top shroud up 180° until it rest on top of the cabinet.

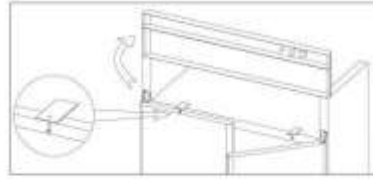

### Door Replacement and Adjustment

1. Open the top shroud and swing it up until it rest on top of the unit.
2. Open the door to about 100-110° until the door remain open.
3. Loosen and remove the top screw of self-closing cartridge and the three hinge screws, then slide the door up and out.
4. Prepare new door. Use a wrench to rotate the square head of the cartridge shaft approximately 120° in the closing direction of the door. The hinge is now preloaded and ready to be secured to the top hinge
5. Hold the door at about 100° from the close position, insert the top hinge over the square shaft of the cartridge so that the hinge is facing the cabinet. Insert the mounting screw and fasten securely.
6. Still holding the the entire door/hinge assembly at about 100°, slide it over the bottom hinge pin, make sure all the alignment then fasten the upper hinge securely
7. Allow the door to freely swing, make sure it swing close by itself with no restriction
8. Plug the unit in and make sure the interior light turn off and active the evap fan when door close
9. If not, adjust the door height by adding the plastic spacer/washer provided to the bottom hinge pin

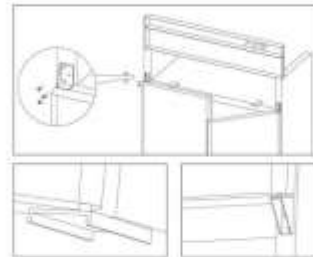

### Remove the bottom shroud (apply to bottom-mounted condenser only)

Loosen and remove the top screws, slide the shroud up and out





## ***Drains and other Maintenance***

### **Drain Maintenance**

Each unit has a drain located inside the unit which removes the condensation from the evaporator coil and evaporates it at an external condensate evaporator pan. Each drain can become loose or disconnected from moving or bumping the drain. If you notice excessive water accumulation on the inside of the unit, be sure the drain tube is connected from the evaporator housing to the condensate evaporator drain pan. If water is collected underneath the unit you may want to check the condensate evaporator drain tube to be sure it is still located inside the drain pan. The leveling of the unit is important as the units are designed to drain properly when on a level surface, if your floor is not level this can also cause drain problems. Be sure all drain lines are free of obstructions typically food product is found blocking drain lines causing water to back up and overflow the drain pans.

### **Salad/ Sandwich and Pizza Prep Condiment Pans**

Pictured below is an example of how condiment pans should be used on a prep unit. Condiment pans must be in place at all times, even if they are empty. Rails and divider bars must be free of damage so the condiment pans will make a good seal to prevent warm air from entering the cabinet. Metal condiment pans should not be used as the corners get damaged and allows warm air to enter into the cabinet. Damage rails or dividers can cause the evaporator to freeze up. To maintain a trouble free unit take care of the pans, rails and divider bars to make a good seal.



## ***Replacing Lamps for Glass Door Merchandisers***

1. Top display light bulb replacement: Loose the screws in the bottom of top shroud, swing the top shroud up until it is hold by the top of the cabinet, now light bulb can be replaced;
2. Interior light bulb replacement: Open door and remove the cover. Twist and remove the bulb.

***Entrée LLC***  
***Refrigeration Products***  
***Service Manual***



Entrée Service Department Contact info:

1-704-900-2068