

Direct Draw Beer Dispensers



BCBD3-1



BCBD3-2



BCBD4-2

Model	Number of Faucets
BCBD3-1-HC	2
BCBD3-2-HC	2
BCBD4-2-HC	4

STANDARD FEATURES

- Designed to accommodate a variety of beer kegs
- 3" diameter stainless steel insulated beer column
- Cold air is channeled directly into beer column to reduce foaming and maximize beer draft profits.
- Stainless Steel interior - s/s 430
- Powder-mated steel black exterior
- Warranty: 2 years parts and labor additional 3 years- compressor

***Not suitable for installation in a non-commercial or residential applications.**

Items	Description	Items	Description
External top/side	Powder matted steel	Temperature control	Solid State T-stat with Digital Display
Interior	Stainless steel	Comply to standard	ETL LISTED, ANSI / NSF-7
External Top	Stainless steel	Refrigerating system	Capillary tube
External sides & back	Powder matted steel	Refrigerant	R290
Cabinet internal	430 stainless steel	Temp. Range in box	34°F — 38°F
Internal floor	430 stainless steel	Evaporator/Condenser	Aluminum + Copper
Insulation	Polyurethane (CFC free)	Condensing unit	Side Mount
Lighting	LED	Doors	Hinged Doors

BEER DISPENSERS





DETAILS AND DIMENSIONS

BCBD3-1-HC

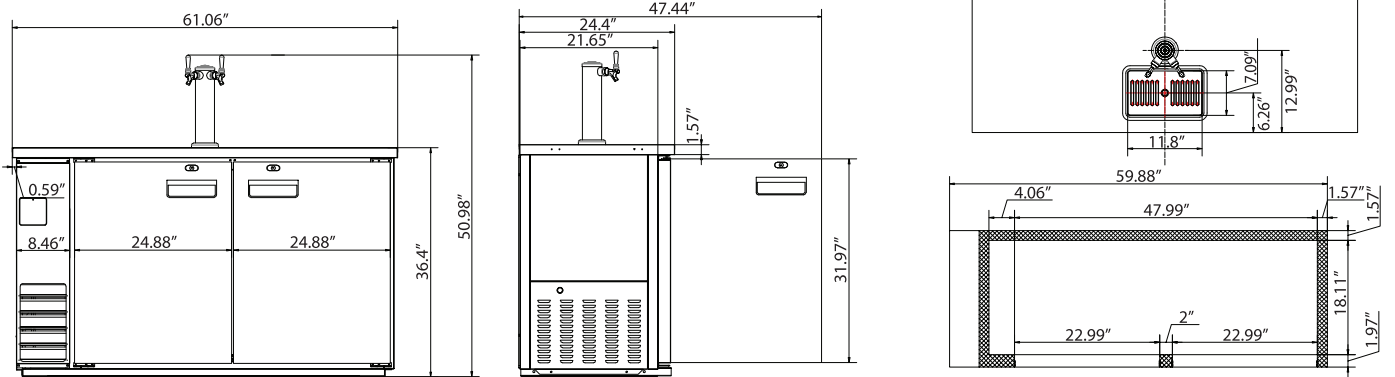

BCBD3-2-HC

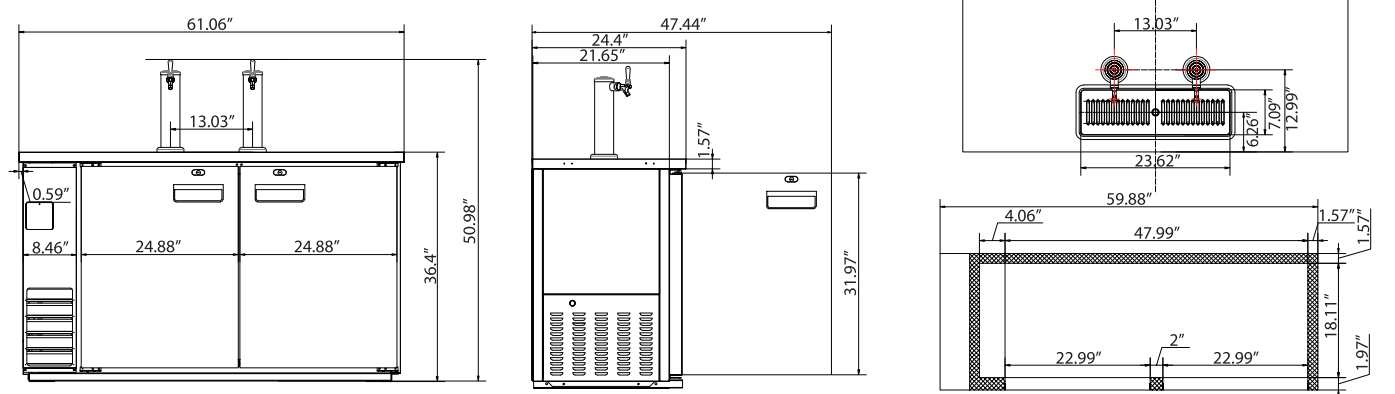

BCBD4-2-HC

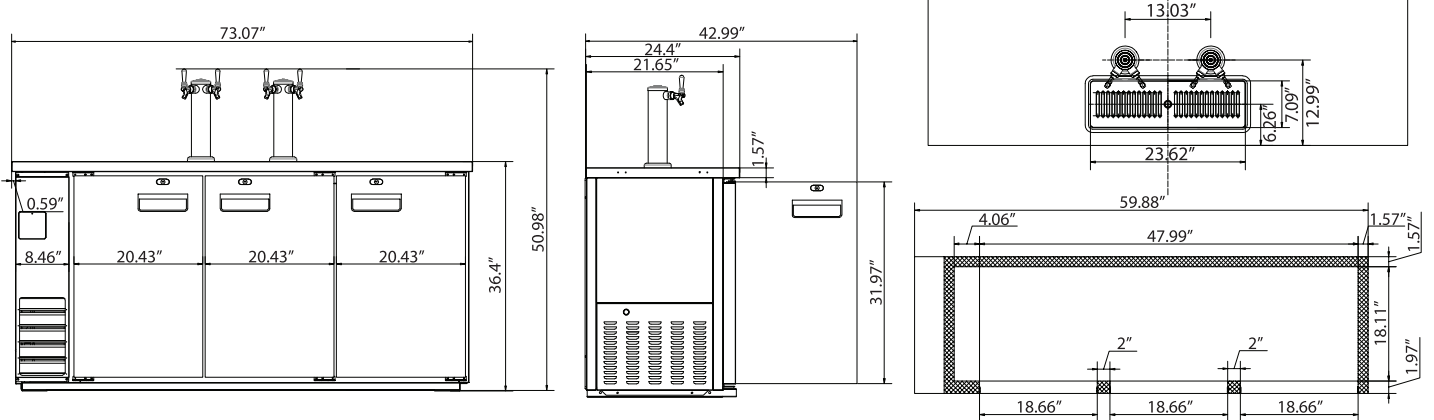

Model	# of Faucets	External Dim (in)			HP	Voltage /Hz /ph	Amp	NEMA Plug	Cord Lgth (ft)	Crated Weight (lbs)
		W	D	H						
BCBD3-1-HC	2	61.06	24.4	36.4	2/5	115/60/1	3.0	5-15P	8.2	309
BCBD3-2-HC	2	61.06	24.4	36.4	2/5	115/60/1	3.0	5-15P	8.2	318
BCBD4-2-HC	4	73.1	24.4	36.4	1/2	115/60/1	3.0	5-15P	8.2	366