



Gas Regulator Included

COMMERCIAL GAS STOCK POT RANGE

Model
SP-1
SP-2



STANDARD FEATURES

- Stainless steel construction
- Heavy duty 1-7/8" thick removable cast iron top grate
- 3-ring cast iron burner
- Dual control valves
- 2 standing pilot lights for instant ignition
- 8" adjustable legs
- Removable crumb tray for easy cleaning
- 3/4" rear NPT gas inlet, pressure regulator supplied

Warranty: Entrée's exclusive parts and labor FUSS warranty takes effect from 1 year after end user purchase.

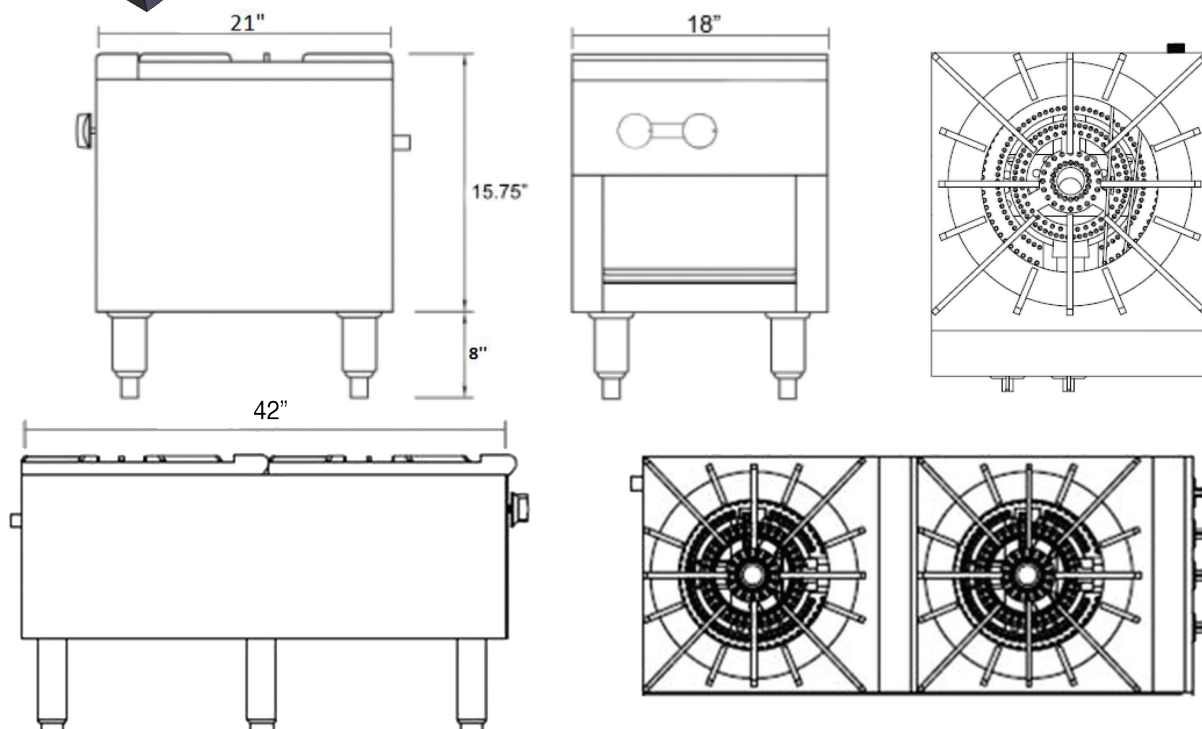

*Not suitable for installation in a non-commercial or residential applications.

Model	Burners	External Dimensions			Total BTU's		Crated Weight (lbs)
		W	D	H	Natural	LP	
SP-1	1 (3 rings, 2 valves)	18	21	24	80,000	80,000	145
SP-2	2 (3 rings, 2 valves)	18	42	24	160,000	160,000	292

COMMERCIAL COOKING

