



FREE STANDING GAS FRYERS - THREE, FOUR & FIVE TUBE FRYER



Model	Capacity
F-3	40 LB
F-4	50 LB
F-5	70 LB

GAS SHALL BE:

- Natural Gas
- Propane

STANDARD FEATURES

- Peened Stainless Steel tank with smoothed out welds
- Stainless Steel Front; top ledge and header
- 1 1/4" Ball type – Full Port Drain
- Cool Zone in Fry Tank
- Built in Flue Deflector
- Efficient (30,000) BTU Heat Exchange Tubes with high heat baffles: 3, 4 and 5 tube fryers available
- Double Rod Stainless Steel Basket Hanger
- Stainless Steel door with door stabilizer
- Smooth Finish, High Grade G90 galvanized sides and back
- Two nickel chrome wire mesh fry baskets - Red Plastic Coated Handles
- Invensys Thermostat - 200°F to 400°F
- Auto reset high limit
- 6 inch adjustable legs, casters available
- Full foam zone
- Heavy construction; shipping weight 200 lb
- Welded door magnet
- Recessed door handle
- Warranty: 1 year parts and labor

SPECIFICATIONS

Entrée Model F-3, F-4, and F-5 are floor standing 3, 4 or 5 tube fryers in 40, 50 and 70 pound capacities. The fry tank is a peened all stainless steel tank with an efficient high heat battle system, cool zone and a 1 1/4" full port drain valve. The front and door is all stainless steel. Door is supported for extra strength with a welded magnet and reversible door handle. Two fry baskets are included with red plastic coated handles. 1 millivolt thermostat allows a temperature range of 200° F to 400°F. A back up safety Hi Limit control shuts the fryer down if shortening exceeds the maximum temperature. The Thermostat, Gas Valve and Hi Limit are Invensys/Robertshaw parts.

ACCESSORIES

- Non adjustable casters
- Stainless Steel Tank Covers
- Grease Strips

*Not suitable for installation in a non-commercial or residential applications.

Customer Service (704)-900-2068 - Fax (888) 388-6017 - www.entree.biz



FREE STANDING GAS FRYERS



DETAILS AND DIMENSIONS

IMPORTANT INFORMATION:

- A combination valve with pressure regulator is provided with this unit.
Natural Gas 4.0" (102 mm) W.C.
Propane Gas 10.0" (279 mm) W.C.
- This fryer is not intended and should never be installed for home use and is manufactured with approvals for commercial installation only
- Requires a 6" (152mm) clearance on the sides and rear to combustible surfaces.
- Requires a 16" (407mm) minimal clearance to open top burner units or any open flames.
- Pressure regulator is provided in the combination valve; Pressure for Natural Gas 4" and Propane 10"
- Adequate ventilation and fire protection system for Commercial application of deep fat frying systems is required.
- Gas connection is 3/4" NPT (19mm) rear gas connection

Model	Width		Depth		Height			Gas Connection		Total BTU/HR	Crated Weight
	A	B	C	D	E	F	G	H	I		
F-3	15.5"	14.0"	30.3"	14.0"	41.5"	34.7"	6.0"	4.2"	7.0"	90,000	169 lbs
F-4	15.5"	14.0"	30.3"	14.0"	41.5"	34.7"	6.0"	4.2"	7.0"	120,000	183 lbs
F-5	21.0"	18.0"	34.3"	18.0"	41.5"	34.7"	6.0"	4.2"	7.0"	150,000	209 lbs

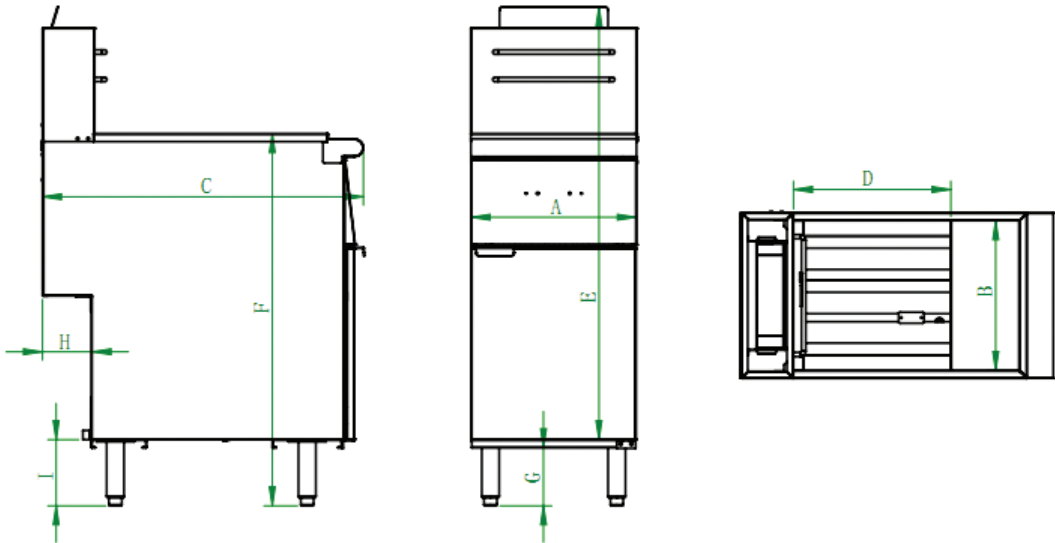

GAS SUPPLY AND BURNER INFORMATION

Supply pressure should be minimum of 4" W.C. for natural gas or 10" W.C. for propane. The fryer has one 3/4" NPT male connector located in the rear.

Model	Burners	Gas Type	Manifold Pressure	Number of heat tubes	Rate Each BTU/HR	Total BTU/HR	Orifice Size
F-3	Main	Natural	4" W.C.	3	30,000	90,000	#39
		Propane	10" W.C.	3	30,000	90,000	#52
F-4	Main	Natural	4" W.C.	4	30,000	120,000	#39
		Propane	10" W.C.	4	30,000	120,000	#52
F-5	Main	Natural	4" W.C.	5	30,000	150,000	#39
		Propane	10" W.C.	5	30,000	150,000	#52

* Minimum supply pressure is 4" W.C. for natural gas and 10" W.C. for propane.

** Orifice sizes are for units installed at altitudes between 0 and 2000 feet above sea level.